

**MODEL 2100
3 POINT MOUNTED PLANTER
(Stack Folding)**

**OPERATOR & PARTS
MANUAL**

M0160

Rev. 10/98

This manual is applicable to: Model: 2100 Stack Folding 3 Point Mounted Planters
Serial Number: 602942 and on

Record the model number and serial number of your planter with date purchased:

Model Number _____ 2100 _____

Serial Number _____

Date Purchased _____

SERIAL NUMBER

The serial number plate is located on the planter frame to be readily available. It is suggested that the serial number and purchase date also be recorded above.

The serial number provides important information about your planter and may be required to obtain the correct replacement part. Always provide the serial number and model number to your KINZE® Dealer when ordering parts or anytime correspondence is made with KINZE Manufacturing, Inc.

07229624

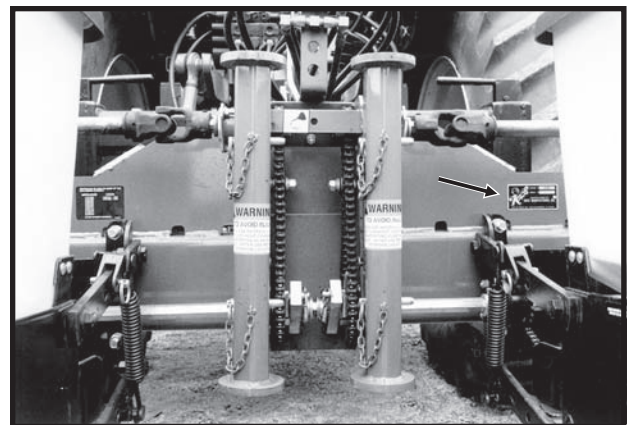

PREDELIVERY/DELIVERY CHECK LIST

TO THE DEALER

Predelivery service includes assembly, lubrication, adjustment and test. This service helps to ensure that the planter will be delivered to the customer ready for field use.

PREDELIVERY CHECK LIST

After the planter has been completely assembled, use the following check list and inspect the planter. Check off each item as it is found satisfactory or after proper adjustment is made.

- Recheck to be sure row units and optional attachments are properly spaced and assembled.
- Be sure all grease fittings are in place and lubricated.
- Check planter and make sure all working parts are moving freely, bolts are tight and cotter pins are spread.
- Check all drive chains for proper tension and alignment.
- Check for oil leaks and proper hydraulic operation.
- Check to be sure hydraulic hoses are routed correctly to prevent damage to hoses.
- Inflate tires to specified PSI air pressure. Tighten wheel bolts to specified torque.
- Check to be sure all safety decals are correctly located and legible. Replace if damaged.
- Check to be sure the red reflectors and amber reflectors are correctly located and visible when the planter is in transport position.
- Check to be sure SMV sign is in place.
- Check to be sure safety/warning lights are installed correctly and working properly.
- Paint all parts scratched in shipment or assembly.
- Be sure all safety lockups are on the planter and correctly located.

This planter has been thoroughly checked and to the best of my knowledge is ready for delivery to the customer.

(Signature of Set-Up Person/Dealer Name/Date)

OWNER REGISTER

Name _____

Date Sold _____

Street Address _____

Model _____

City, State/Province & Zip _____

Serial Number _____

Dealer Name _____

Dealer Number _____

DELIVERY CHECK LIST

At the time the planter is delivered, the following check list is a reminder of very important information which should be conveyed to the customer. Check off each item as it is fully explained to the customer.

- Advise the customer that the life expectancy of this or any other machine is dependent on regular lubrication as directed in the Operator & Parts Manual.
- Tell the customer about all applicable safety precautions.
- Along with the customer, check to be sure the red reflectors, amber reflectors and SMV sign are clearly visible with the planter in transport position and attached to the tractor. Check to be sure safety/warning lights are in working condition. Tell the customer to check federal, state/provincial and local regulations before towing or transporting on a road or highway.
- Give the Operator & Parts Manual to the customer and explain all operating adjustments.
- Read warranty to customer.
- Complete Warranty And Delivery Report form.

To the best of my knowledge this machine has been delivered ready for field use and customer has been fully informed as to proper care and operation.

(Signature of Delivery Person/Dealer Name/Date)

AFTER DELIVERY CHECK LIST

The following is a list of items we suggest to check during the first season of use of the equipment.

- Check with the customer as to the performance of the planter.
- Review with the customer the importance of proper maintenance and adherence with all safety precautions.
- Check for parts that may need to be adjusted or replaced.
- Check to be sure all safety decals, SMV sign and reflectors are correctly located and legible. Replace if damaged or missing.
- Check to be sure safety/warning lights are working properly.

(Signature of Follow-Up Person/Dealer Name/Date)

**RETURN THIS COMPLETED FORM TO KINZE® IMMEDIATELY, along with Warranty And Delivery Report.
Retain photocopy of this form at dealership for After Delivery Check.**

Tear Along Perforation

TABLE OF CONTENTS

TO THE OWNER	1-1
WARRANTY	1-2
INTRODUCTION	2-1
SPECIFICATIONS	3-1
SAFETY PRECAUTIONS	4-1
SAFETY WARNING SIGNS	5-1
MACHINE OPERATION	
Checking Granular Chemical Application Rate.....	6-19
Checking Seed Population.....	6-18
Contact Drive Wheel Spring Adjustment	6-5
Dual Lift Assist Wheels	6-11
Electronic Seed Monitor System	
KM1000 Monitor	6-13
KM3000 Monitor	6-15
KPM I/KPM II Monitor.....	See Assembly Instruction IS364
Field Test6-12	
Flow Control Valve Adjustment	6-11
General Planting Rate Information	6-20
Half Rate (2 To 1) Drive	6-4
Hydraulic Operation.....	6-6
Initial Preparation Of The Planter	6-1
Leveling The Planter	6-3
Marker Adjustment	6-6
Marker Operation.....	6-6
Marker Speed Adjustment	6-7
Metric Conversion Table	6-11
Parking Stand Adjustment	6-3
Planting And Application Rate Charts	6-21
Planting Speed	6-12
Point Row Wrap Spring Clutch	6-9
Shear Protection.....	6-5
Standard Rate Drive.....	6-4
Tire Pressure	6-5
Two-Speed Point Row Wrap Spring Clutch.....	6-10
Tractor Preparation And Hookup	6-1
Tractor Requirements	6-1
Transmission Adjustment.....	6-4
Transporting The Planter	6-12
Wheel Module Height Adjustment	6-4
Wing Down Flex Cylinder	6-8
Wing Flex.....	6-7
ROW UNIT OPERATION	
Brush-Type Seed Meter.....	7-4
Coulter Mounted Residue Wheel.....	7-14
Covering Discs/Single Press Wheel Adjustment	7-2
Disc Furrowers (For Use With Frame Mounted Coulter).....	7-11
Dual Gauge Wheel	7-7
Finger Pickup Seed Meter	7-3
Frame Mounted Coulter.....	7-9
Granular Chemical Banding Options	7-16
Granular Chemical Hopper.....	7-15
Granular Chemical Restrictor Plate	7-15
Planting Depth.....	7-1
Quick Adjustable Down Force Springs	7-8
Row Unit Chain Routing	7-7
Row Unit Gauge Wheel Cover.....	7-7
Row Unit Mounted Bed Leveler	7-12
Row Unit Mounted Disc Furrower.....	7-11

TABLE OF CONTENTS

ROW UNIT OPERATION (Continued)	
Row Unit Mounted No Till Coulters.....	7-13
Row Unit Mounted Residue Wheel.....	7-12
Seed Firming Wheel.....	7-14
Seed Hopper.....	7-5
Seed Meter Drive Adjustment.....	7-6
Seed Meter Drive Release.....	7-6
Spring Tooth Incorporator.....	7-16
“V” Closing Wheel Adjustment.....	7-1
LUBRICATION	
Bushings.....	8-4
Drive Chains.....	8-2
Grease Fittings.....	8-6
Lubrication Symbols.....	8-1
Point Row Wrap Spring Clutches.....	8-1
Sealed Bearings.....	8-1
Wheel Bearings.....	8-1
MAINTENANCE	
15" Seed Opener Disc/Bearing Assembly.....	9-8
Brush-Type Seed Meter Maintenance.....	9-5
Brush-Type Seed Meter Troubleshooting.....	9-7
Cam Follower Adjustment.....	9-20
Chain Tension Adjustment.....	9-1
Closing Wheel Troubleshooting.....	9-7
Electrical Wiring Diagrams	
Light Package.....	9-24
Point Row Wrap Spring Clutches.....	9-25
Two-Speed Point Row Wrap Spring Clutches.....	9-26
Electronic Seed Monitor Display Backlite Bulb Replacement (KM3000 Only).....	9-16
Electronic Seed Monitor Row Indicator Bulb Replacement (KM1000 Only).....	9-16
Electronic Seed Monitor System Troubleshooting.....	9-10
Finger Pickup Seed Meter Cleaning.....	9-3
Finger Pickup Seed Meter Troubleshooting.....	9-4
Finger Pickup Seed Meter Inspection/Adjustment.....	9-2
Flow Control Valve Inspection.....	9-20
Gauge Wheel Adjustment.....	9-8
Hydraulic Schematics	
Dual Lift Assist Wheel Package.....	9-29
Dual Lift Assist Wheel Package (Plumbed Into 3 Point Circuit).....	9-29
Fold System.....	9-28
Marker System.....	9-28
Wing Down Flex Cylinder Package.....	9-30
Wing Down Flex Cylinder Package And Dual Lift Assist Wheel Package.....	9-30
Marker Bearing Lubrication Or Replacement.....	9-23
Marker Operation Troubleshooting.....	9-22
Marker Sequencing/Flow Control Valve Inspection.....	9-21
Mounting Bolts And Hardware.....	9-1
Point Row Wrap Spring Clutch Inspection.....	9-17
Point Row Wrap Spring Clutch Troubleshooting.....	9-18
Preparation For Storage.....	9-24
Row Unit Mounted No Till Coulters.....	9-9
Seed Tube Guard/Inner Scraper.....	9-9
Torque Values Chart.....	9-1
Two-Speed Point Row Wrap Spring Clutch.....	9-19
Wheel Bearing Lubrication Or Replacement.....	9-23
PARTS LIST INDEX.....	P1
PARTS SECTION NUMERICAL INDEX.....	a

TO THE OWNER

KINZE Manufacturing, Inc. would like to thank you for your patronage. We appreciate your confidence in KINZE® farm machinery. Your KINZE® planter has been carefully designed and sturdily built to provide dependable operation in return for your investment.

This manual has been prepared to aid you in the operation and maintenance of the planter. It should be considered a permanent part of the machine and remain with the machine when you sell it.

It is the responsibility of the user to read and understand the Operator and Parts Manual in regards to safety, operation, lubrication and maintenance before operation of this equipment. It is the user's responsibility to inspect and service the machine routinely as directed in the Operator and Parts Manual. We have attempted to cover all areas of safety, operation, lubrication and maintenance; however, there may be times when special care must be taken to fit your conditions.

Throughout this manual the symbol  and the words **NOTE, CAUTION, WARNING** and **DANGER** are used to call your attention to important safety information. The definition of each of these terms used follows:

NOTE: Indicates a special point of information.

CAUTION: Indicates that a failure to observe can cause damage to the machine or equipment.



WARNING: Indicates that a failure to observe can cause damage to the machine or equipment and/or personal injury.



DANGER: Indicates that a failure to observe can cause most serious damage to the machine or equipment and/or most serious personal injury.



WARNING: Some photos in this manual may show safety covers, shields or lockups removed for visual clarity. **NEVER OPERATE** the machine without all safety covers, shields and lockups in place.

NOTE: Some photos in this manual may have been taken of prototype machines. Production machines may vary in appearance.

NOTE: Some photos and illustrations in this manual show optional attachments installed. Contact your KINZE® Dealer for purchase of optional attachments.

WARRANTY

The KINZE® Limited Warranty for your new machine is stated on the back of the retail purchaser's copy of the Warranty And Delivery Report form.

Warranty, within the warranty period, is provided as part of KINZE's support program for registered KINZE® products which have been operated and maintained as described in this manual. Evidence of equipment abuse or modification beyond original factory specifications will void the warranty. Normal maintenance, service and repair is not covered by KINZE® warranty.

To register your KINZE® product for warranty, a Warranty And Delivery Report form must be completed by the KINZE® Dealer and signed by the retail purchaser, with copies to the Dealer, to the retail purchaser and to KINZE Manufacturing, Inc. Registration must be completed and sent to KINZE Manufacturing, Inc. within 30 days of delivery of the KINZE® product to the retail purchaser. KINZE Manufacturing, Inc. reserves the right to refuse warranty on serial numbered products which have not been properly registered.

Additional copies of the Limited Warranty can be obtained through your KINZE® Dealer.

If service or replacement of failed parts which are covered by the Limited Warranty are required, it is the user's responsibility to deliver the machine along with the retail purchaser's copy of the Warranty And Delivery Report to the KINZE® Dealer for service. KINZE® warranty does not include cost of travel time, mileage, hauling or labor. Any prior arrangement made between the Dealer and the retail purchaser in which the Dealer agrees to absorb all or part of this expense should be considered a courtesy to the retail purchaser.

KINZE® warranty does not include cost of travel time, mileage, hauling or labor.

INTRODUCTION

The Model 2100 Stack Folding 3 Point Mounted planter is available in various configurations and row spacings and permits installation of various row unit attachments.

81014-47

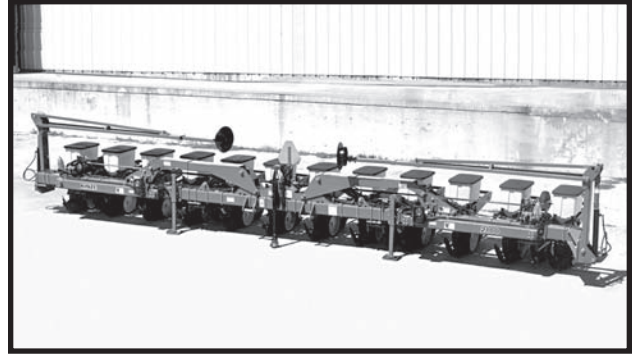

GENERAL INFORMATION

The information used in this manual was current at the time of printing. However, due to KINZE's continual attempt to improve its product, production changes may cause your machine to appear slightly different in detail. KINZE Manufacturing, Inc. reserves the right to change specifications or design without notice and without incurring obligation to install the same on machines previously manufactured.

Right hand and left hand as used throughout this manual is determined by facing in the direction the machine will travel when in use unless otherwise stated.

81014-32



INTRODUCTION

SPECIFICATIONS

TYPE - 3 Point Mounted (Stack Folding)

ROW UNIT TYPE - Pull Row Units

ROW SPACING - 8 Row Wide (38" - 40" Rows)
12 Row Narrow (30" Rows)
12 Row Wide (36" - 38" Rows)
12 Row Wide (38" - 40" Rows)
16 Row Narrow (30" Rows)

DRIVE SYSTEM

Spring-loaded contact drive system.
Two 4.10" x 6" contact drive tires.
Four 7.60" x 15" ground tires.
Two wheel module-mounted seed transmissions with No. 40 chains and spring-loaded idlers.
Optional point row clutches.
7/8" hex drill and drive shafts.

HYDRAULICS

Wing Fold - Single remote.
Marker Package Option - Single remote with sequencing/flow control valve.
Dual Lift Assist Wheel Package Option - *Single remote.
Wing Down Flex Package Option - *Single remote.

*A single remote can operate both Dual Lift Assist Wheel Package and Wing Down Flex Package Options.

HITCH - Category 3N - 3 (Optional Category 2)

MACHINE OPTIONS

- Row Markers - Low profile two-fold with depth band on marker blades.
- Electronic Seed Monitors - KM1000, KM3000 with magnetic distance sensor or KM3000 with radar distance sensor.
(KPM I/KPM II Monitor - See Assembly Instruction IS364)
- Two-Speed Point Row Wrap Spring Clutch Package - Allows half width planting and reduced rate planting. (Available through KINZE® Repair Parts.)
- Point Row Wrap Spring Clutch Package - Allows half width planting.
- Half Rate (2 To 1) Drive Reduction Package
- Dual Lift Assist Wheel Package (8 Row Wide size requires removal of center section gauge wheels to accommodate dual lift assist wheels.)
- Wing Down Flex Cylinder Package

ROW UNIT OPTIONS/ATTACHMENTS

- Finger Pickup Or Brush-Type Seed Meters
- Closing Wheels - Rubber "V", Cast Iron "V" Or Covering Discs/Single Press Wheel
- Gauge Wheel Covers
- Spring Tooth Incorporator
- Granular Chemical Application
- Row Unit Mounted No Till Coulter
- Row Unit Mounted Disc Furrowers
- Row Unit Mounted Bed Leveler
- Row Unit Mounted Residue Wheel
- Coulter Mounted Residue Wheels
- Frame Mounted No Till Coulter
- Disc Furrowers For Frame Mounted Coulter
- Seed Firming Wheel

SPECIFICATIONS

DIMENSIONS & WEIGHTS

PLANTER SIZE	TRANSPORT WIDTH	TRANSPORT HEIGHT *	WEIGHT**
8 Row 38" - 40" – W/O Markers	16' 1"	11' 2"	5368 lbs.
8 Row 38" - 40" – W/Markers	16' 11"	13' 2"	5888 lbs.
12 Row 30" – W/O Markers	16' 1"	11' 2"	6224 lbs.
12 Row 30" – W/Markers	17' 9"	13' 2"	6824 lbs.
12 Row 36" - 38" – W/O Markers	18' 5"	12' 6"	6529 lbs.
12 Row 36" - 38" – W/Markers	19' 6"	15' 6"	7184 lbs.
12 Row 38" - 40" – W/O Markers	21' 1"	12' 6"	6609 lbs.
12 Row 38" - 40" – W/Markers	22' 2"	15' 6"	7279 lbs.
16 Row 30" – W/O Markers	21' 1"	12' 6"	7464 lbs.
16 Row 30" – W/Markers	23' 0"	15' 6"	8144 lbs.

* Lower link pins at 42" height.

** Base machine weight includes toolbar and 3 point hitch, wheel modules with tires and wheels, seed transmission(s) with drive components, parking stands, optional row markers with hydraulic cylinders and hoses (where applicable) and KINZE® pull row units (closing wheel arms less closing wheels) with seed hopper and lid, quick adjustable dual down force springs.

SAFETY PRECAUTIONS

Safe and careful operation of the tractor and planter at all times will contribute significantly to the prevention of accidents.

Since a large portion of farm accidents occur as a result of fatigue or carelessness, safety practices should be of utmost concern. Read and understand the instructions provided in this manual and on the warning signs. Review these instructions frequently. Listed below are other safety suggestions that should become common practice.

 **Never permit any persons other than the operator to ride on the tractor.**

 **Never ride on the planter or allow others to do so.**

 **Be aware of bystanders, particularly children! Always look around to make sure it is safe to start the engine of the towing vehicle or move the planter. This is particularly important with higher noise levels and quiet cabs, as you may not hear people shouting.**

 **Always keep hands, feet and clothing away from moving parts. Do not wear loose fitting clothing which may catch in moving parts.**

 **Always wear protective clothing, substantial shoes and suitable hearing and eye sight protectors applicable for the situation.**

 **Use a tractor equipped with a roll-over-protective-system and fasten your seatbelt prior to starting the engine.**

 **Do not allow anyone to stand between the hitch and the towing vehicle when backing up to the planter.**

 **Limit transport speed to 15 MPH. Transport only with farm tractor of sufficient size and horsepower. (See Machine Operation Section)**

 **Never allow the planter to be operated by anyone who is unfamiliar with the operation of all functions of the unit. All operators should read and thoroughly understand the instructions given in this manual prior to moving the unit.**

 **Always make sure safety/warning lights, SMV sign and reflectors are in place and visible prior to transporting the machine on public roads. In this regard, check federal, state/provincial and local regulations.**

 **Never work under the planter while in raised position.**

 **Always make sure there are no persons near the planter when marker assemblies are in operation.**

 **Watch for obstructions such as wires, tree limbs, etc., when folding markers.**



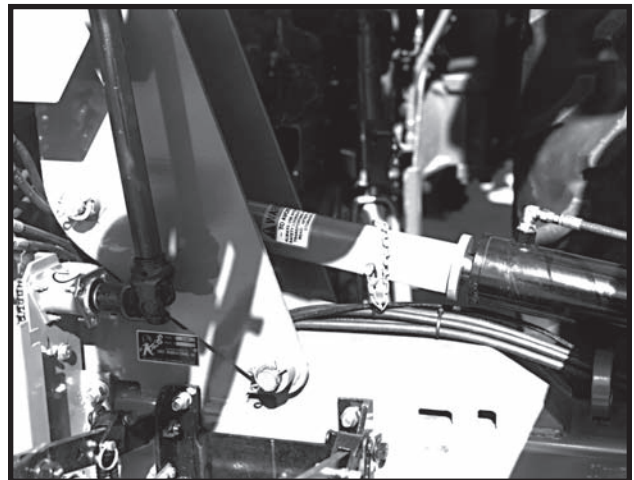

















81014-89



 **Install safety lockups on wing fold cylinders, as provided, prior to transporting the planter or working around the unit.**

 **Lower the planter when not in use and cycle the hydraulic control lever to relieve pressure in hoses.**

SAFETY PRECAUTIONS

-  Before applying pressure to the hydraulic system, make sure all connections are tight and that hoses and fittings have not been damaged. Hydraulic fluid escaping under pressure can have sufficient force to penetrate skin causing injury or infection.
-  This planter is designed to be **DRIVEN BY GROUND TIRES ONLY**. The use of hydraulic, electric or PTO drives may create serious safety hazards to you and the people near by. If you install such drives you must follow all appropriate safety standards and practices to protect you and others near this planter from injury.
-  Due to the transport height of the wings, watch for obstructions such as wires, tree limbs, etc.
-  Never transport folding machines with lift assist wheels without quick hitch. If this type of hitch is not in place, a sudden stop could allow the toolbar to rotate forward causing personal injury or damage to the equipment.
-  Always make sure there are no persons near the planter when planter wings are being lowered from transport position.
-  If a marker or wing lift cylinder has been removed for any reason, do not attach the rod end of the cylinder until the cylinder is cycled several times to remove air that may be trapped in the system.
-  Allow for unit length when making turns.
-  Reduce speed prior to turns to avoid the risk of overturning.
-  Wings must be unfolded before detaching machine from tractor.
-  Check to be sure all safety/warning lights are working before transporting the machine on public roads.
-  Always drive at a safe speed relative to local conditions and ensure your speed is low enough for an emergency stop to be safe and secure. Keep speed to a minimum.
-  Avoid sudden uphill turns on steep slopes.
-  Always keep the tractor in gear to provide engine braking when going downhill. Do not coast.
-  Be a safe and courteous driver. Always yield to oncoming traffic in all situations, including narrow bridges, intersections, etc.
-  Store the planter in an area away from human activity. **DO NOT** permit children to play in or around the stored unit.
-  Make sure the parked machine is on a hard, level surface.
-  Rim and tire servicing can be dangerous. Explosive separation of a tire and rim parts can cause serious injury or death.
-  Agricultural chemicals used with this unit can be dangerous. Improper selection or use can seriously injure persons, animals, plants, soil and other property. **BE SAFE:** Select the right chemical for the job. Handle it with care. Follow the instructions of the chemical manufacturer.
-  Serious injury or death can result from contact with electric lines. Use care to avoid contact with electric lines when moving or operating this machine.
-  This machine has been designed and built with your safety in mind. Do not make any alterations or changes to this machine. Any alteration to the design or construction may create safety hazards.
-  Good maintenance is your responsibility. Poor maintenance is an invitation to trouble.

SAFETY WARNING SIGNS

The “WARNING” signs illustrated on these pages are placed on the machine to warn of hazards. The warnings found on these signs are for your personal safety and those around you. **OBSERVE THESE WARNINGS!**

- Keep these signs clean so they can be readily observed. Wash with soap and water or cleaning solution as required.
- Replace “WARNING” signs should they become damaged, painted over or if they are missing.
- Check SMV sign periodically. Replace if it shows loss of any of its reflective property.
- When replacing decals, clean the machine surface thoroughly using soap and water or cleaning solution to remove all dirt and grease.



Part No. G7100-25
(Qty. 2)



Part No. G7100-140
(Qty. 1)



Part No. G7100-117
(Qty. 1)



Part No. G7100-204
(Qty. 2)

81014-67a

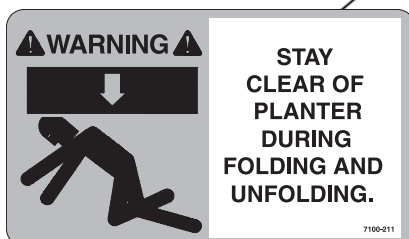
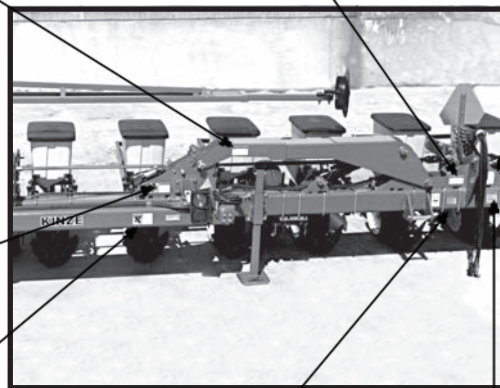

Part No. G7100-211
(Qty. 2)



Part No. G7100-90
(Qty. 1)

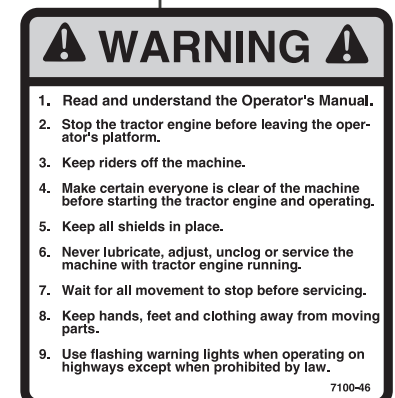

Part No. G7100-46
(Qty. 1)

SAFETY WARNING SIGNS

03279823

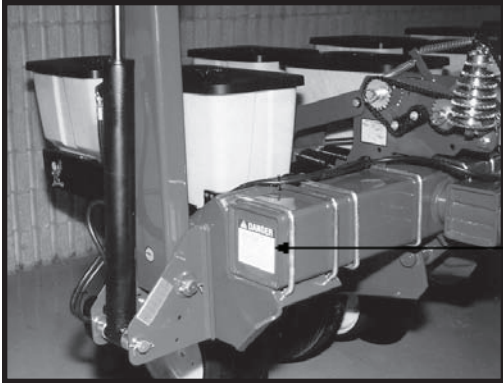

 **DANGER**

THIS PLANTER IS DESIGNED TO BE DRIVEN BY GROUND TIRES ONLY. THE USE OF HYDRAULIC, ELECTRIC OR PTO DRIVES MAY CREATE SERIOUS SAFETY HAZARDS TO YOU AND THE PEOPLE NEARBY. IF YOU INSTALL SUCH DRIVES YOU MUST FOLLOW ALL APPROPRIATE SAFETY STANDARDS AND PRACTICES TO PROTECT YOU AND OTHERS NEAR THIS PLANTER FROM INJURY.

7100-89

Part No. G7100-89
(Qty. 2)

06109601



 **WARNING**

TO AVOID INJURY -- STAND CLEAR--KEEP OTHERS AWAY WHEN RAISING OR LOWERING MARKERS. BEFORE TRANSPORTING PLANTER FULLY EXTEND HYDRAULIC CYLINDERS AND INSTALL LOCKING PINS WHERE PROVIDED.

7100-42

Part No. G7100-42
(Qty. 2 Per Marker)

07229616



Part No. GD2199
(Qty. 1)

SAFETY WARNING SIGNS

81014-72

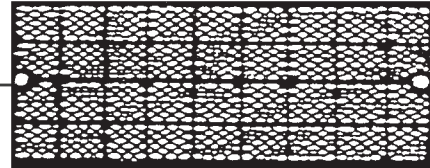
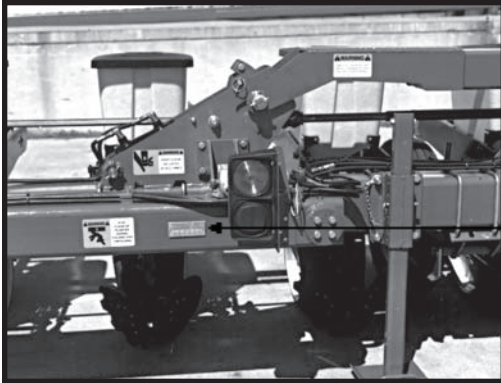

Part No. G7200-04 (Qty. 2)
Amber Reflector - Front Of Machine

81014-36

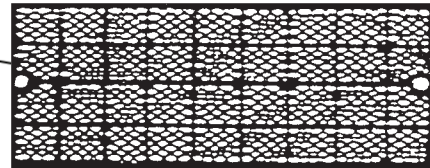
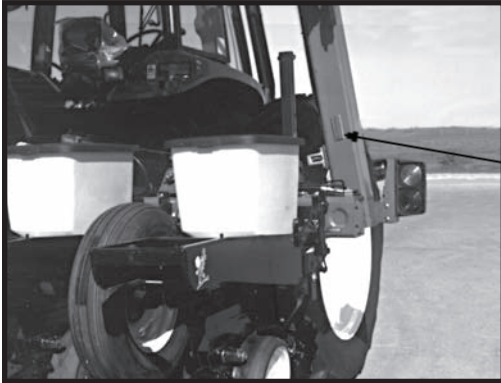

Part No. G7200-03 (Qty. 2)
Red Reflector - Rear Of Machine

81014-89

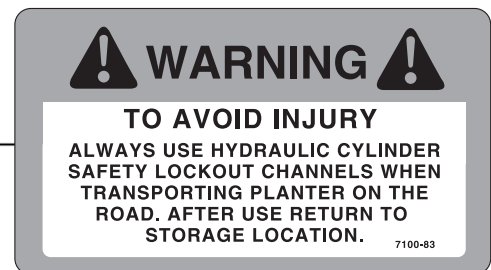

Part No. G7100-83
(Qty. 2)

SAFETY WARNING SIGNS

77178-17a

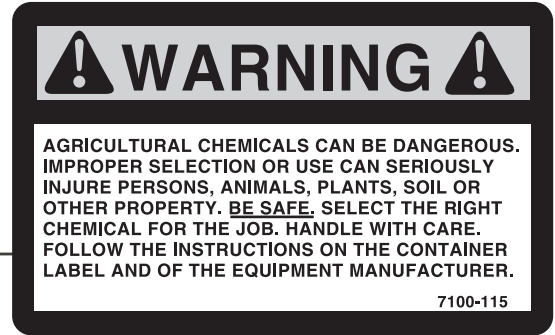

Part No. G7100-115
Located on under side of granular
chemical hopper lids.

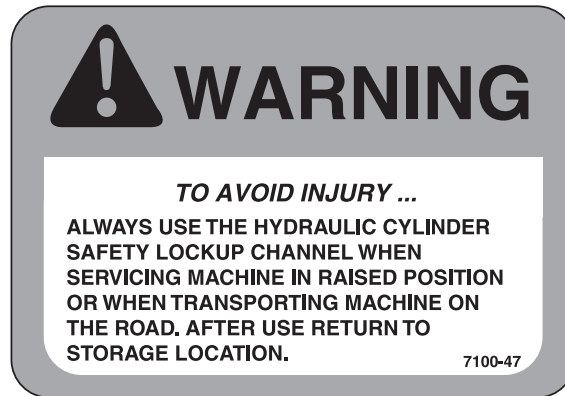

Part No. G7100-47 (Qty. 2)
Dual Lift Assist Wheel Package

A7443/A5482(SFP52)

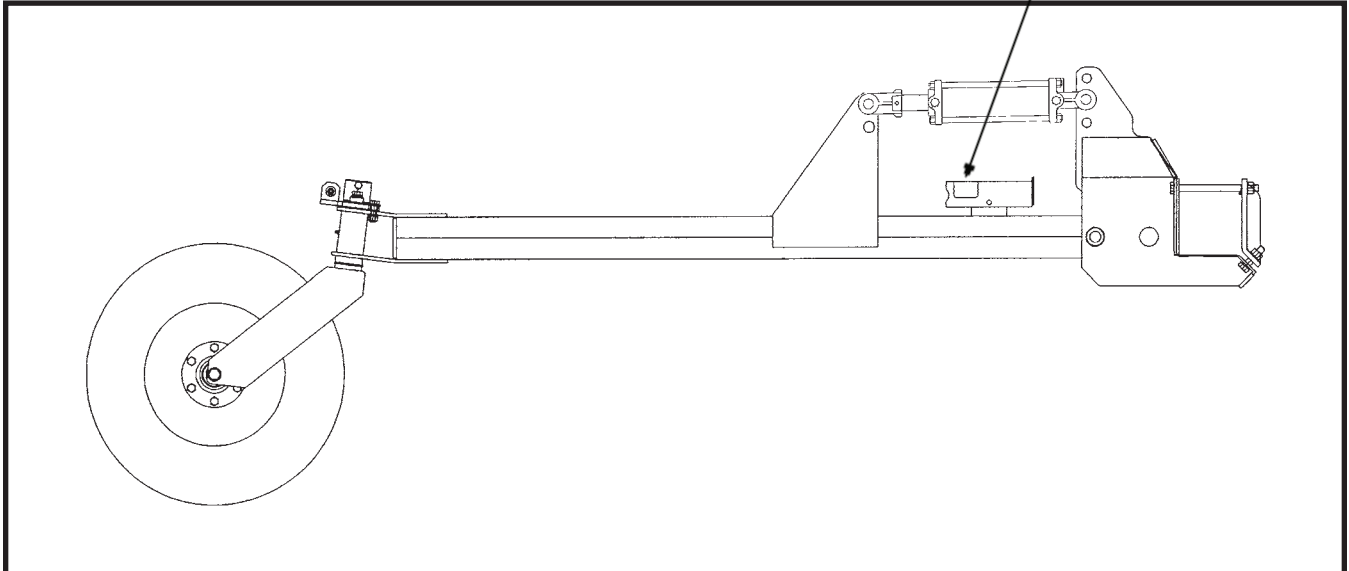

MACHINE OPERATION

The following information is general in nature and was written to aid the operator in preparation of the tractor and planter for use, and to provide general operating procedures. The operator's experience, familiarity with the machine and the following information should combine for efficient planter operation and good working habits.

CAUTION: Always raise the planter out of the ground when making sharp turns or backing up.

The dual lift assist wheel option requires customer-supplied quick hitch to operate without center link pin. 8 row wide planters require removal of the center section gauge wheels to accommodate dual lift assist wheels.

INITIAL PREPARATION OF THE PLANTER

Lubricate the planter and row units per the lubrication information in this manual. Make sure all tires have been properly inflated. See "Tire Pressure." Check all drive chains for proper tension, alignment and lubrication.

TRACTOR REQUIREMENTS

Approximate required minimum tractor horsepower (H.P.) required for field work is listed below:

- 8 Row Wide - 125 H.P. And Up
- 12 Row Narrow - 150 H.P. And Up
- 12 Row Wide And 16 Row Narrow - 180 H.P. And Up

NOTE: Tractor must have adequate 3 point hitch lift capacity to lift weight of machine, attachments, seed and dry chemicals. Shipping weights do not include seed, dry chemicals or additional optional attachments.

Tractor front end stability is necessary for safe and efficient operation. Therefore, it may be necessary to add front ballast to your tractor for satisfactory field operation, as well as adequate transport stability. Refer to your tractor operator's manual for front ballast recommendations.

TRACTOR PREPARATION AND HOOKUP

1. Set tractor rear wheel spacing at double the planter row spacing. For example: On a planter set for 38" rows, set the tractor wheel spacing at 76". On wide front end tractors set front wheel spacing equal to rear wheel spacing. Check tractor operator's manual for correct front and rear tire pressure.
2. Adjust lift links on tractor so planter will lift level from side to side and raise high enough for planter transport clearance. Set the sway blocks on the tractor in position to prevent side sway. Be sure the individual lift link arms are in the float position.
3. Back tractor up to planter. Position lower hitch pins and bushings as shown in the following diagrams for your type of tractor hitch. Line up holes and insert hitch pins and lock in place with pins provided. It may be necessary to change the length of the upper link with the adjusting handle.

Lower Hitch Pins

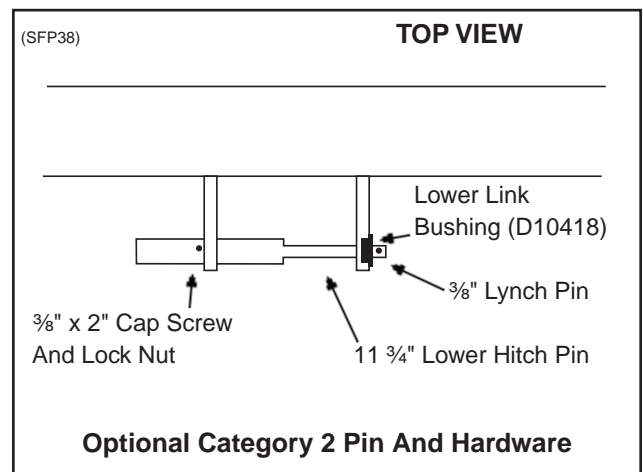
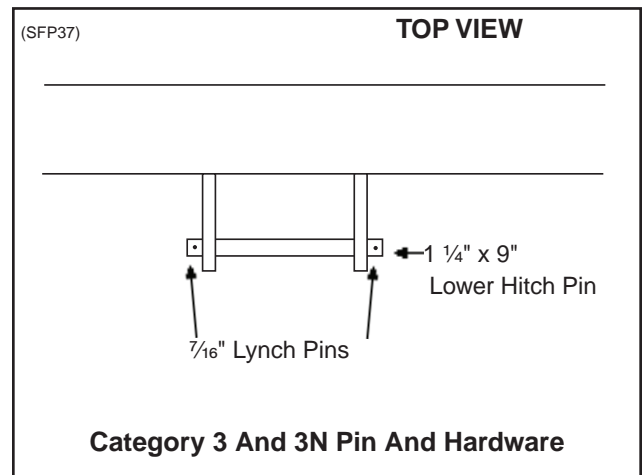

MACHINE OPERATION

The upper hitch point has two holes. The hitch pin must be positioned in the lower hole for use with tractors equipped with Category 2 quick hitch and is recommended for use on tractors without a quick hitch. Some Category 2 tractors without a quick hitch are designed to accommodate the upper attaching holes. Consult tractor manufacturer.

The hitch pin must be positioned in the upper hole for use with tractors equipped with Category 3 and 3N hitches.

When using a quick hitch (customer supplied), match pin location to pin spacing in the quick hitch. Adjust the tractor upper link until the quick hitch is vertical when in the planting position.

Dual lift assist wheel equipped machines require use of a quick hitch (customer supplied) and the top link pin is not used.

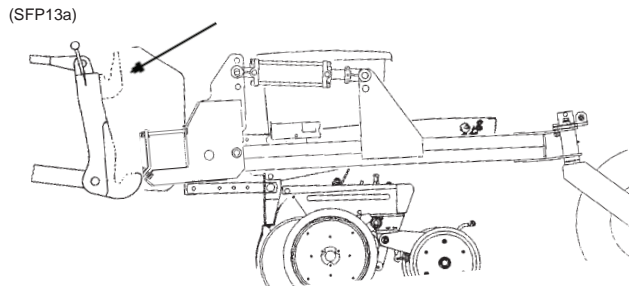

WARNING: Never transport machine with lift assist wheels without quick hitch. If this type of hitch is not in place, a sudden stop could allow the toolbar to rotate forward causing personal injury or damage to the equipment.

Upper Hitch Pin

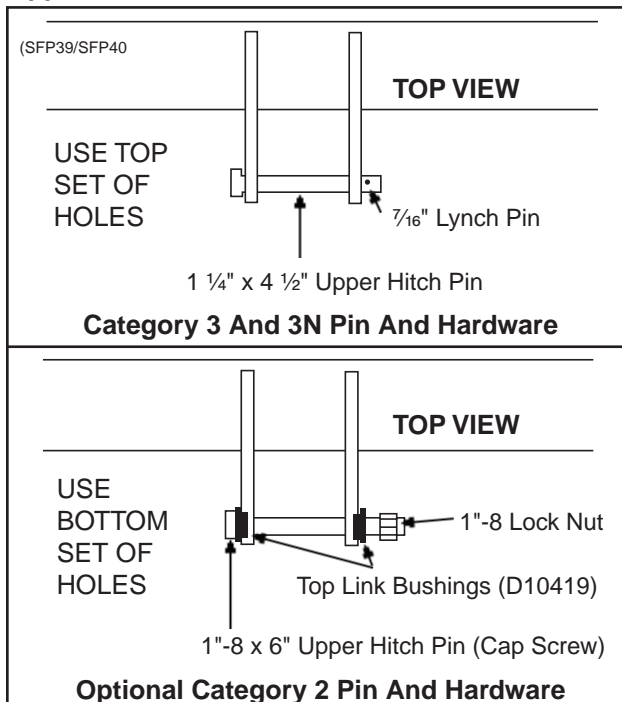

- The planter is equipped with safety/warning lights which should be used whenever the planter is being transported. The connector is a 7 terminal break-away connector conforming to ASAE standards. If your tractor is not equipped for safety/warning lights, check with your tractor dealer.
- Connect hydraulic hoses to tractor ports in a sequence that is both familiar and comfortable to the operator. See "Hydraulic Operation".

Before attaching hoses, move tractor SCV levers back and forth to relieve any pressure in the tractor hydraulic system.

IMPORTANT: Always wipe hose ends to remove any dirt before connecting couplers to tractor ports.

CAUTION: Before the markers are operated, make sure all marker lockups are in working position.

DANGER: Before applying pressure to the hydraulic system, make sure all connections are tight and that hoses and fittings have not been damaged. Hydraulic fluid escaping under pressure can have sufficient force to penetrate skin causing injury or infection.

- With planter on a level surface, raise the planter slowly and watch for any interference.

When raising a planter equipped with dual lift assist wheels, the front of the planter should raise and then the back using the lift assist wheels to raise the rear of the planter. When lowering the planter, the lift assist wheels should begin to lower the rear of the planter before lowering the front of the planter. If the dual lift assist wheels are plumbed into the 3 point hitch lift circuit, adjust the flow control valve so the rear of the planter lowers before the front of the planter and the front of the planter raises before the rear of the planter. See "Flow Control Valve Adjustment". With planter lowered to planting position, adjust tractor linkage to level the toolbar. See "Leveling The Planter".

MACHINE OPERATION

With planter (equipped with dual lift assist wheels) raised for transport, maintain a minimum of 3" clearance between planter and quick hitch.

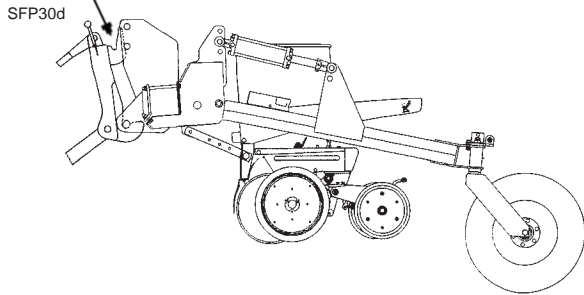

On planters equipped with the optional Dual Lift Assist Wheel Package, adjustment holes on the lift assist cylinder mounts allow for adjustment of lift height.

(SFP13b)

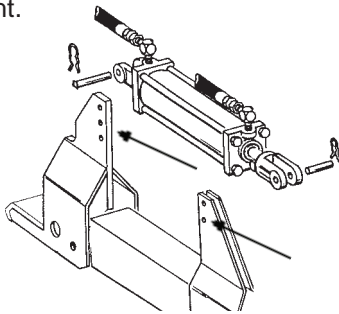

7. Remove pin from each parking stand and raise each to the transport position. Secure stands in raised position with pin in lowest hole.
8. Lower the planter so the drive wheels rest on the ground and check to be sure planter is level. Re-adjust top link as required to level row units. See "Leveling The Planter".

CAUTION: As a general safety practice and to avoid damage to the tractor hydraulic system, always lower the planter when not in use.

LEVELING THE PLANTER

For proper operation of the planter and row units, it is important that the planter frame and row unit parallel arms be level. The toolbar should operate at a 20" to 22" height, measured to the bottom of the toolbar.

When operating the planter, make sure the right and left lower link arms on the tractor are adjusted equally before attaching the planter. After the planter has been lowered to the correct operating height, stop the tractor and stand beside the planter and check to be sure the frame is level fore and aft. If the row units angle up or down, adjust the center link on the tractor accordingly.

It is important for the planter to operate level laterally. Tire pressure must be maintained at pressures specified and drive wheel height must be adjusted equally. See "Wheel Module Height Adjustment".

PARKING STAND ADJUSTMENT

81014-79

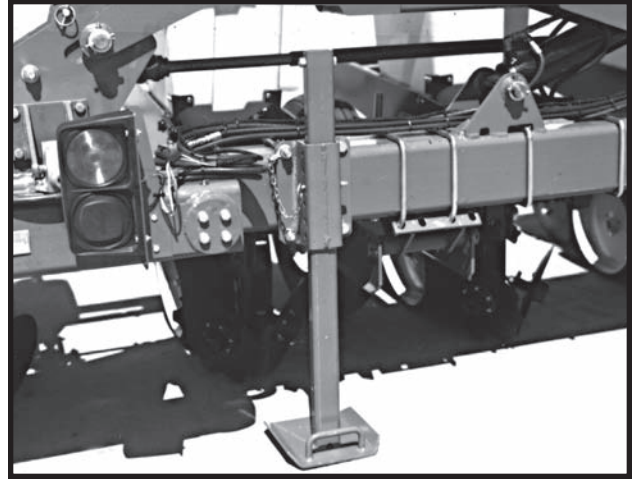

81014-75



Two parking stands, located on the front side of the main frame, are standard on all Model 2100 planters. The stands must be positioned so they are not directly behind the tractor tire or they will hit when the planter is raised.

Raise to top position and pin when planting. Lower and pin for parking and storage.

Each parking stand has six positioning holes. By using these positioning holes, you can set the main frame parking height from 19" to 25".

MACHINE OPERATION

TRANSMISSION ADJUSTMENT

81014-86

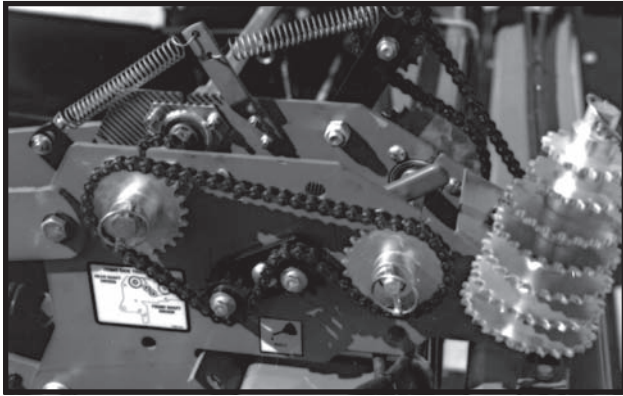

Planting population rate changes are made at the seed transmissions. The planter transmissions are designed to allow simple, rapid changes in sprockets to obtain the desired planting population. By removing the lynch pins on the hexagon shafts, sprockets can be interchanged with those from the sprocket storage rod bolted to each transmission.

Chain tension is controlled by a spring-loaded, dual-sprocket idler. The idler assembly is adjusted with a ratchet arm. This arm has a release position to remove spring tension for replacing sprockets. The amount of spring tension on the chain can be controlled by the ratchet arm.

A decal positioned near the transmission illustrates proper chain routing. The planting rate charts found at the back of this section will aid you in selecting the correct sprocket combinations.

STANDARD RATE DRIVE

A7293

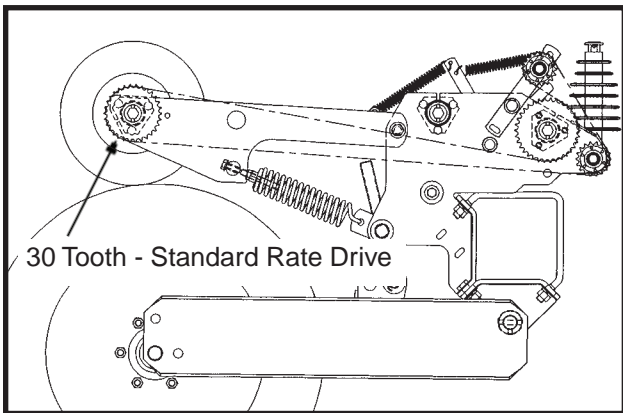

Seed planting rate charts are based on the standard rate drive. The standard rate drive uses a 30 tooth sprocket on each contact drive tire. Using the 15 tooth half rate (2 to 1) drive sprocket in place of the 30 tooth sprocket will reduce the planting rate by approximately 50%. See "Half Rate (2 To 1) Drive".

HALF RATE (2 TO 1) DRIVE

Replacing the 30 tooth drive sprocket, located on the contact drive tire shaft, with the 15 tooth half rate (2 to 1) drive reduction sprocket will reduce the planter transmission speed and reduce planting rates by approximately 50%. See "General Planting Rate Information" at the back of this section.

IMPORTANT: After each sprocket combination adjustment, make a field check to be sure you are planting at the desired rate.

A7293a

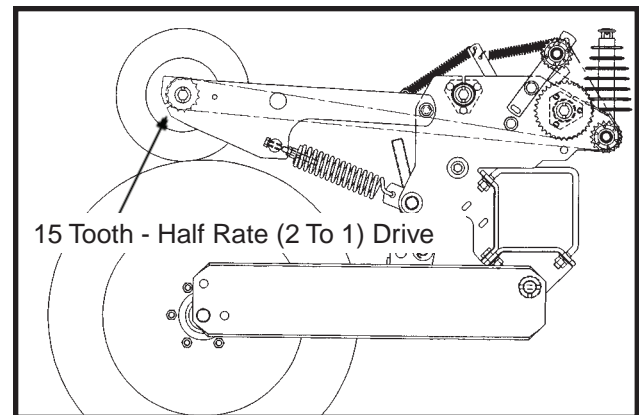

WHEEL MODULE HEIGHT ADJUSTMENT

81014-95

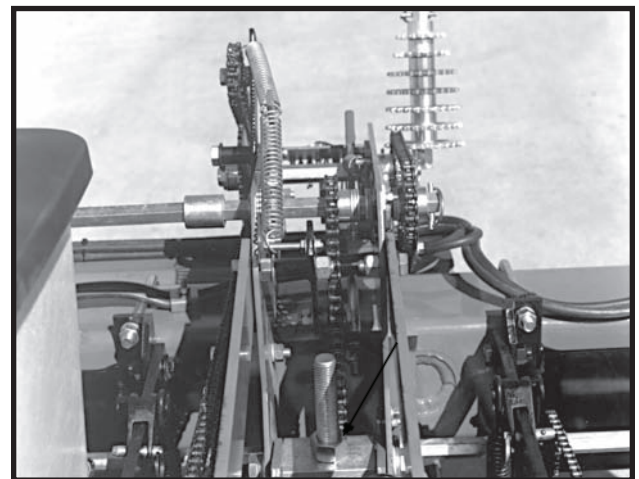

Drive Wheel Module Assembly

MACHINE OPERATION

07229625

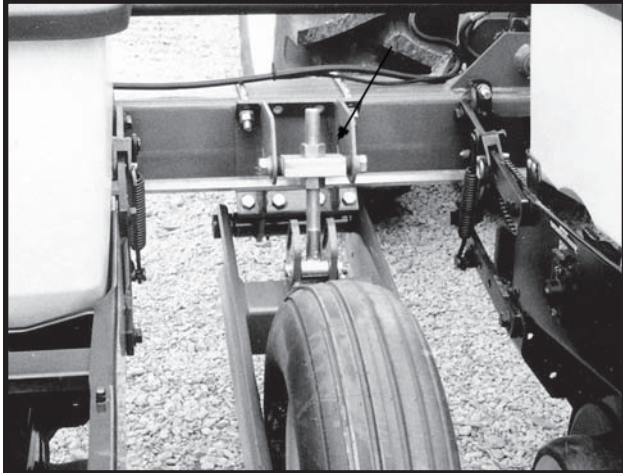

**Center Section Gauge Wheel Assembly
(Standard On All Serial No. 602972 And On)**

The drive wheel module assembly and center section gauge wheel assembly is designed so the drive wheel height can be adjusted to maintain a frame height of 20" to 22" in all planting situations. This is particularly useful when the planter is used for ridge planting or planting on beds. The wheel module assembly has an adjustment range of 7". To adjust the wheel assembly, loosen the upper nut using a 1 1/2" wrench or a 15" adjustable wrench and turn the lower nut using a 1 1/2" wrench or 15" adjustable wrench (clockwise to decrease frame height or counterclockwise to increase frame height). Tighten the upper nut.

CONTACT DRIVE WHEEL SPRING ADJUSTMENT

There are two down pressure springs on each contact drive wheel. The down pressure is factory preset and should need no further adjustment.

The spring tension is set leaving 1" between the spring plug and the mounting shaft as shown below.

(SPF61)

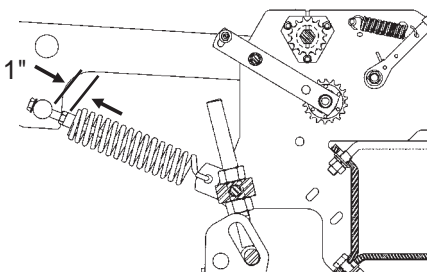

SHEAR PROTECTION

The planter drive line and row unit components are protected from damage by shear pins.

81689-3

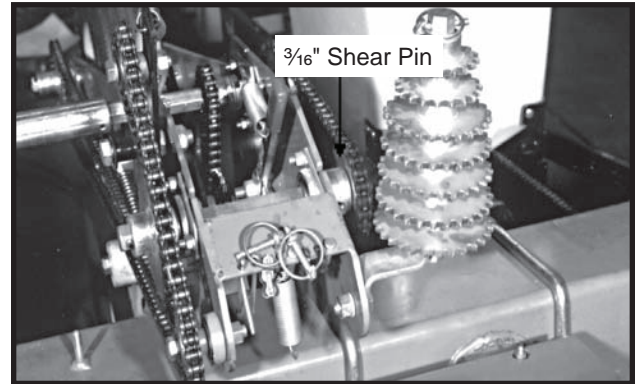

Transmission Shaft

61658-27

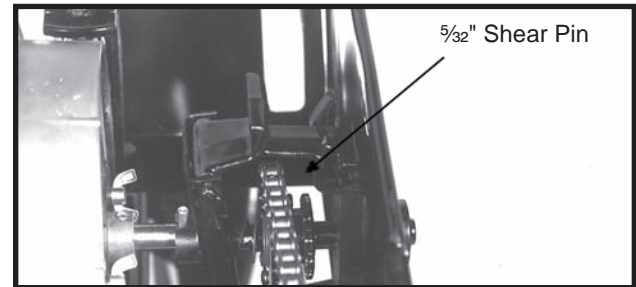

Row Unit Seed Meter Drive

If excessive load should cause a pin to shear, it is important to determine where binding has occurred before replacing the pin. Replace shear pins with same size and type.

To prevent future binding or breakage of components, check drive line alignment and follow prescribed lubrication schedules.

NOTE: Drill shaft/transmission coupler alignment is critical.

TIRE PRESSURE

Tire pressure should be checked regularly and maintained as follows:

- 7.60" x 15" 4 Ply, Ground Drive/Gauge 40 PSI
- 4.10" x 6", Contact Drive 60 PSI

IMPORTANT: Tire pressure must be correctly maintained in all drive wheel tires to insure level and proper operation of planter. All rate charts are based on above tire pressures.

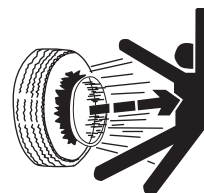

DANGER: Rim and tire servicing can be dangerous. Explosive separation of a tire and rim parts can cause serious injury or death.

MACHINE OPERATION

HYDRAULIC OPERATION

Model 2100 Stack Folding planters require a single control valve for folding the wings. A second control valve is required for the Marker Package. A third valve is required for the Dual Lift Assist Wheel Package and/or the Wing Down Flex Cylinder Package unless these are tied into the tractor 3 point lift system.

81014-39

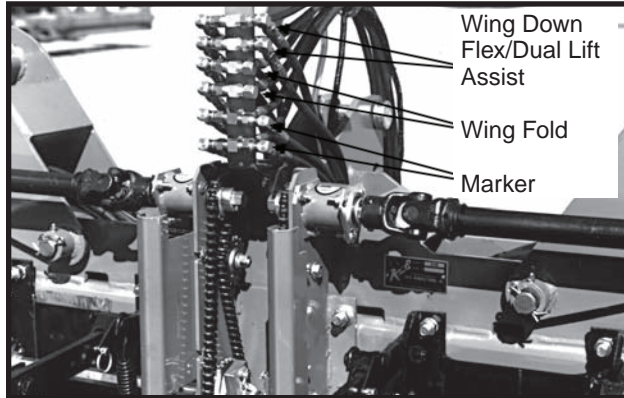

DANGER: If a cylinder has been removed for any reason, do not attach the rod end of the cylinder until the cylinder is cycled several times to remove any air that may be trapped in the system.

The wings are folded and unfolded using a single hydraulic control valve. When the wings are unfolded, the spring-actuated hydraulic latches lock the wings to the fold links so they pivot as one unit.



WARNING: Always be sure planter is in the fully raised position before folding the planter wings.

MARKER OPERATION

The single valve marker system uses a sequencing valve which directs hydraulic flow to operate the markers alternately. Each time a marker is raised, the sequencing valve will direct flow to lower the opposite marker.

Both markers can be used at the same time if desired. To do this, lower the planter and the marker that has been selected. Move the tractor SCV lever to the raised position and immediately return it to the lower position. This will shift the marker control valve and the remaining marker will be lowered. This is useful in planting contours and terraces.



WARNING: Always stand clear of marker assemblies and blades when planter is operating.



DANGER: Serious injury or death can result from contact with electric lines. Use care to avoid contact with electric lines when moving or operating this machine.

MARKER ADJUSTMENT

To determine the correct length at which to set the marker assemblies, multiply the number of rows by the average row spacing in inches. This provides the total planting width. Adjust the marker extension so the distance from the marker blade to the center line of the planter is equal to the total planting width previously obtained. Both the planter and marker assembly should be lowered to the ground when the measurements are being taken. Measurement should be taken from the point where the blade contacts the ground. Adjust right and left marker assemblies equally and securely tighten clamping bolts. An example of marker length adjustment follows:

Number x Row = Dimension Between Planter
Of Rows Spacing Center Line And Marker
(Inches) Blade.

12 Rows	x	30" Row Spacing	=	360" Marker Dimension
---------	---	-----------------	---	-----------------------

The marker blade is installed so the concave side of the blade is outward to throw dirt away from the grease seals. The spindle bracket is slotted so the hub and blade can be angled to throw more or less dirt. To adjust the hub and spindle, loosen the 1/2" hardware and move the bracket as required. Tighten bolts to the specified torque.

IMPORTANT: A marker blade assembly that is set at a sharper angle than necessary will add unnecessary stress to the complete marker assembly and shorten the life of bearings and blades. Set the blade angle only as needed to leave a clear mark.

A field test is recommended to ensure the markers are properly adjusted. After the field test is made, make any minor adjustments as necessary.

60569-53

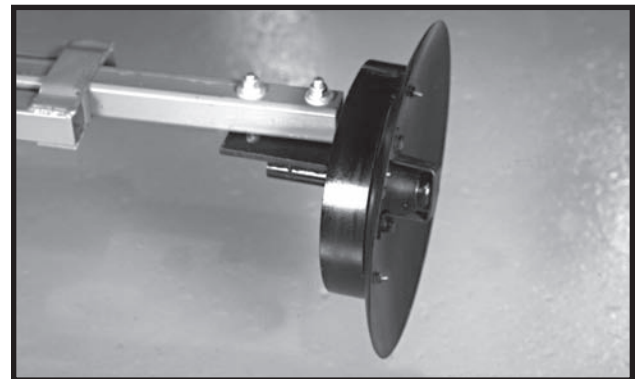

A notched marker blade is available from KINZE® Repair Parts for use in severe no till conditions.

MACHINE OPERATION

MARKER SPEED ADJUSTMENT

Flow control valves located in the marker sequencing/flow control valve assembly control the lowering and raising speed of the markers. One valve controls marker speed raising and one valve controls marker speed lowering.

To adjust marker speed, loosen the jam nut and turn the control clockwise or "in" to slow the travel speed and counterclockwise or "out" to increase the travel speed. The flow control determines the amount of oil flow restriction through the flow control valve, therefore determining travel speed of the markers.

NOTE: Backing the flow control valve out too far can cause the o-ring seal on the valve to fail when hydraulics are operated.

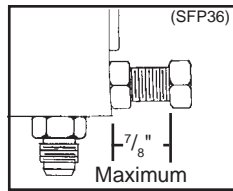

81014-13

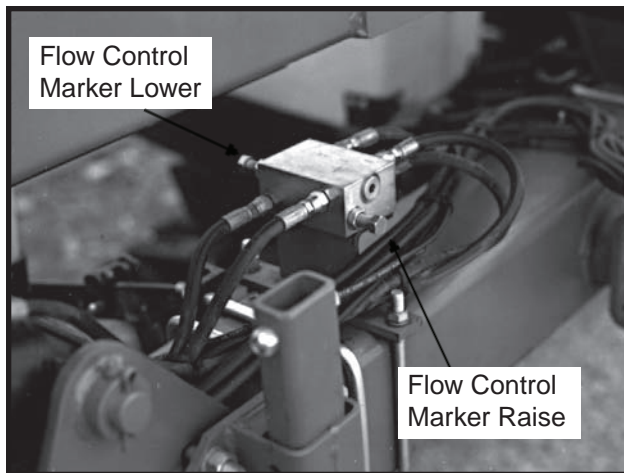

DANGER: The flow controls should be properly adjusted before the marker assembly is first put into use. Excessive travel speed of the markers can be dangerous and/or damage the marker assembly.

NOTE: When oil is cold, hydraulics operate slowly. Make sure all adjustments are made with warm oil. Do not overtighten lock nut.

NOTE: On a tractor where the oil flow can not be controlled, the rate of flow of oil from the tractor may be greater than the rate at which the marker cylinder can accept the oil. The tractor hydraulic control lever will have to be held until the cylinder reaches the end of its stroke. This occurs most often on tractors with an open center hydraulic system. On tractors with a closed center hydraulic system, the tractor's hydraulic flow control can be set so the tractor's detent will function properly.

WING FLEX

Two hooks located over each wing hinge area can be positioned so the toolbar is (a) locked rigid, (b) so the planter wings have 8° up flex or (c) with the Wing Down Flex Cylinder Package (See "Wing Down Flex Cylinder") installed, so the planter wings have 8° up flex and 8° down flex.

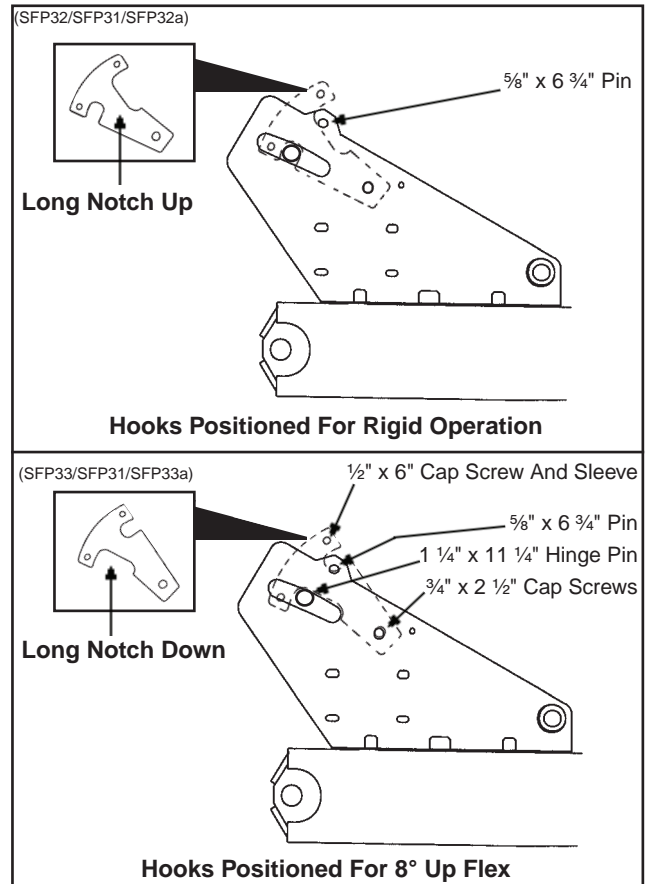

To change the hook from one position to the other:

1. Lower the planter to the ground so weight is off of the toolbar and relieve hydraulic pressure in the wing fold cylinders.
2. Remove lynch pin and 6 3/4" pin.
3. Loosen 3/4" hook mounting hardware and rotate the hooks back off of the hinge pin. (It may be necessary to raise the outer end of the wing up several inches to take pressure off of the hooks to allow them to rotate.)
4. Remove 1/2" x 6" cap screw and sleeve.
5. Remove 3/4" hook mounting hardware.
6. Install hooks in new position. DO NOT tighten 3/4" hardware at this time.

MACHINE OPERATION

7. Install sleeve and 1/2" cap screw in opposite hole.
8. The 3/4" hook mounting hardware should be snug, yet loose enough to allow the hooks to be rotated by hand.
9. Install 6 3/4" pin and lynch pins.

WARNING: Always make sure there are no persons near the planter when planter wings are being lowered from transport position.

DANGER: Serious injury or death can result from contact with electric lines. Use care to avoid contact with electric lines when moving or operating this machine.

DANGER: Wings must be unfolded before detaching machine from tractor.

WARNING: Always install hydraulic cylinder safety lockups when servicing the machine in raised position or when transporting the machine on the road.

WING DOWN FLEX CYLINDER

(SFP31/SFP33a/SFP35)

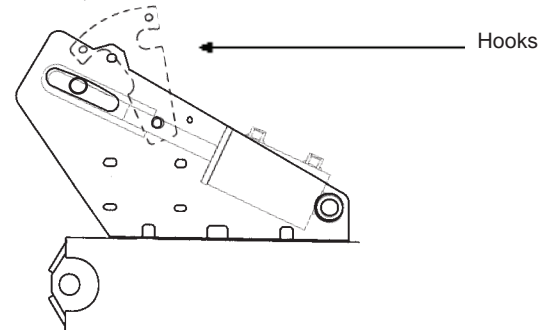

Wing Down Flex Cylinder Installed To Allow 8° Up Flex And 8° Down Flex

To prevent the planter wings from sagging during transport should hydraulic pressure be lost, the hooks located over each hinge area should be repositioned prior to folding the planter. Apply hydraulic pressure to the wing down flex cylinders until they are completely retracted and the wings are rotated up slightly. (3/4" hook mounting hardware should be snug, yet loose enough to allow the hooks to be rotated by hand.) Remove lynch pin and 6 3/4" pin, rotate hooks to hook over hinge pin as shown below and reinstall 6 3/4" pin above hooks. Relieve hydraulic pressure on down flex cylinders and allow wings to come back to level. Fold planter and install lockups on wing fold cylinders. Reverse procedure to unfold planter.

WARNING: Always be sure planter is in the fully raised position before folding the planter wings.

(SFP31/SFP33/SFP35)

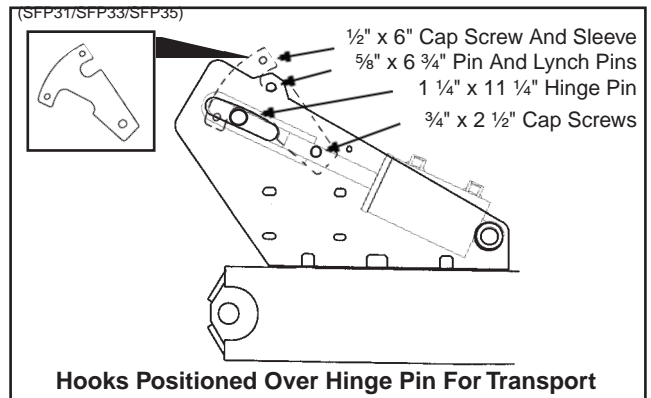

Hooks Positioned Over Hinge Pin For Transport

MACHINE OPERATION

POINT ROW WRAP SPRING CLUTCH

81014-12

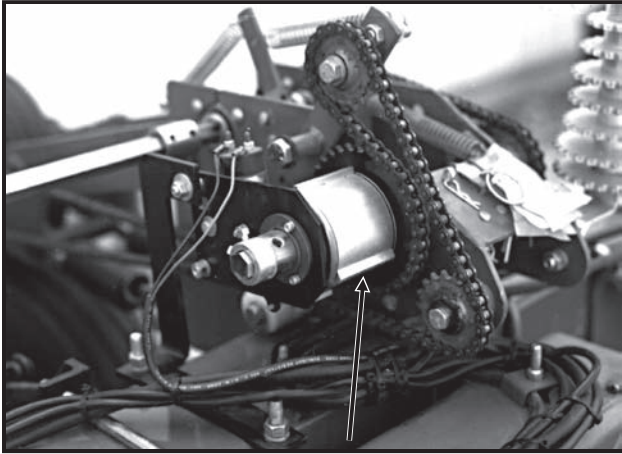

Left Side Of Planter Shown

With the use of electric wrap spring clutches which disengage the drive, the operator has the capability to shut off either half of the planter for finishing up fields or for long point row situations.

76740-48



Point Row Wrap Spring Clutch Control Box

The selector switch for the clutches is located on the tractor.

NOTE: Switch should be left in OFF position when planter is not in use. If left in ON (Left or Right) position it will drain the tractor battery.

(EF40c)

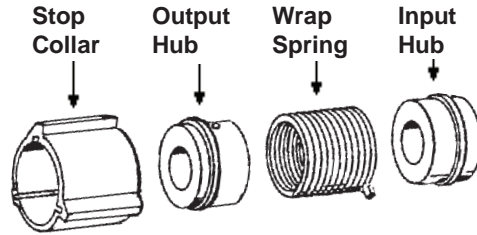

The wrap spring clutch consists of a wrap spring riding on an input hub and an output hub. During operation the wrap spring is wrapped tightly over the hubs connecting them in a positive engagement. The greater the force of rotation the tighter the grip of the spring on the hubs. Rotation in the opposite direction or stopping the spring from rotating prevents the transmission of torque from the input hub to the output hub stopping the planter drive.

The input end of the spring is bent outward and is referred to as the control tang. The control tang fits into a slot in the stop collar that is located between the input and output hubs and over the wrap spring. If the stop collar is allowed to rotate with the input hub, the clutch is engaged. If the stop collar is stopped from rotating the spring tang connected to it is forced back and the spring opens. This allows the input hub to continue rotating without transmitting torque to the output hub; therefore, stopping the planter drive.

The stop collar is controlled by the use of an electric solenoid and an actuator arm. When the selector switch on the tractor control panel is in the OFF position the solenoid coil is NOT ENERGIZED and the actuator arm will not contact the stop on the stop collar allowing it to rotate with the hubs and drive the planter.

When the operational switch is in the "DISENGAGE" (Right or Left) position the solenoid coil IS ENERGIZED and the plunger in the solenoid coil pulls the actuator arm against the stop on the stop collar, disengaging the wrap spring and stopping the planter drive.

MACHINE OPERATION

TWO-SPEED POINT ROW WRAP SPRING CLUTCH

82488-24

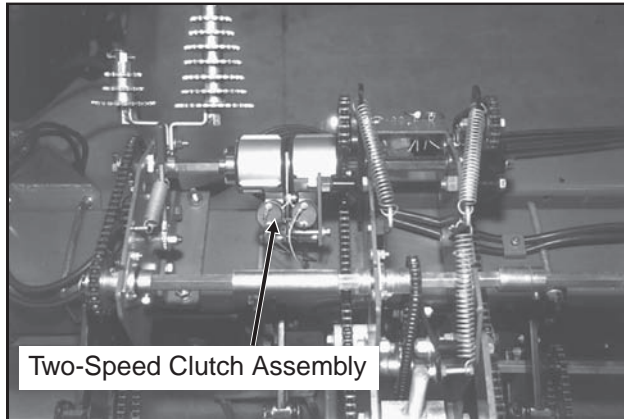

Two-Speed Clutch Assembly

Left Side Of Planter Viewed From Rear Of Planter

The Two-Speed Point Row Clutch Package is designed to allow on-the-go population rate adjustment as well as the capability to shut off either half of the planter for finishing up fields or for long point row situations.

The point row clutches are controlled by the point row clutch switch on the control box. Activating the reduced rate switch engages one solenoid on each clutch assembly and "in operation" reduces the planting rate for the entire planter. The point row switch is used to shut off either the left or right half of the planter.

NOTE: Point row switch should be left in OFF position and rate switch should be left in FULL RATE position when planter is not in use. If left in ON and/or REDUCED RATE position it will drain the tractor battery.

(INS242)

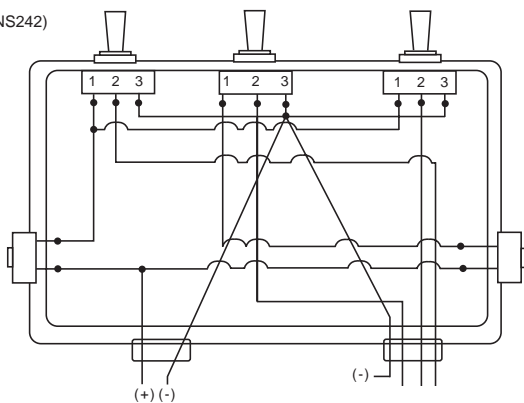

Top View Of Control Box

The ratio of population reduction is determined by the sprocket ratio between the drive and driven sprockets at the contact drive tire. A rate reduction decal like the one shown below is located on the wheel module.

(7100-214)

TRANSMISSION RATE REDUCTION		
DRIVE	DRIVEN	% REDUCTION IN POPULATION
15	30	50
17	30	43
23*	30	23
24	30	20
25*	30	17
26*	30	13
27	30	10

* Use sprockets off seed drive transmission

7100-214

(INS124)

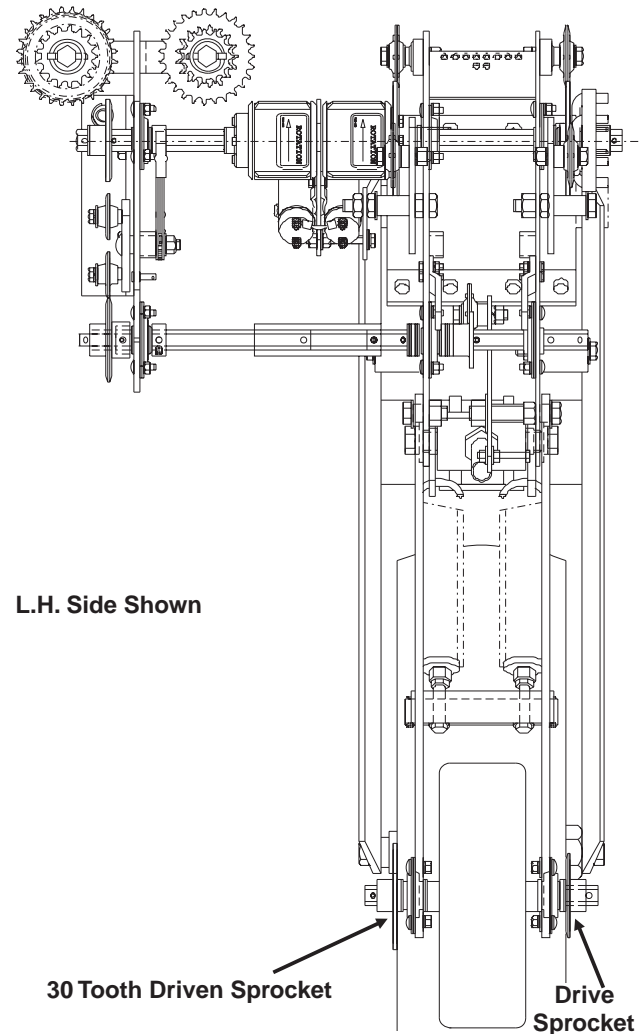

L.H. Side Shown

30 Tooth Driven Sprocket

Drive Sprocket

MACHINE OPERATION

DUAL LIFT ASSIST WHEELS

(SFP52a)

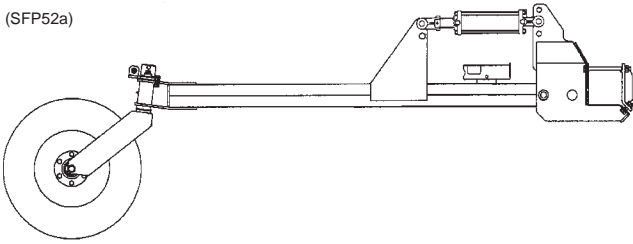

Dual lift assist wheel equipped machines require use of a quick hitch (customer supplied) and the top link pin is not used.

A single control valve operates the dual lift assist wheels.

When raising a planter equipped with dual lift assist wheels, the front of the planter should raise and then the back using the lift assist wheels to raise the rear of the planter. When lowering the planter, the lift assist wheels should begin to lower the rear of the planter before lowering the front of the planter.

If the machine is equipped with both the Dual Lift Assist Wheel Package and Wing Down Flex Cylinder Package, a single control valve operates both options. As the dual lift assist wheel cylinders extend to raise the toolbar, the wing down flex cylinders retract to flex the wings up 5° for added clearance when turning around.

Dual lift assist wheels hydraulics can also be plumbed into the 3 point lift circuit. A flow control valve determines the correct sequence of events to allow the dual lift assist wheel cylinders to operate at the correct time in conjunction with the 3 point hitch lift circuit. See "Flow Control Valve Adjustment".

See "Tractor Preparation And Hookup" for additional information.

FLOW CONTROL VALVE ADJUSTMENT

WB001 (MT2)

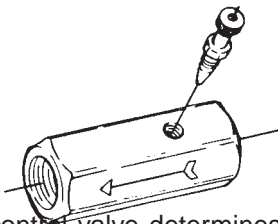

The flow control valve determines the amount of oil flow to the lift assist cylinders.

To adjust oil flow, loosen the jam nut and turn the control clockwise or "in" to restrict flow and counterclockwise or "out" to increase the flow.

METRIC CONVERSION TABLE

Multiply	By	To Get
Inches (in.)	x 2.54	= centimeters (cm)
Inches (in.)	x 25.4	= millimeters (mm)
Feet (ft.)	x 30.48	= centimeters (cm)
Acres	x 0.405	= hectares (ha)
Miles per hour (mph)	x 1.609	= kilometers per hour (kmph)
Pounds (lbs.)	x 0.453	= kilograms (kg)
Bushels (bu.)	x 35.238	= liters (l)
Gallons (gal.)	x 3.785	= liters (l)
Pounds per square inch (psi)	x 6.894	= kilopascals (kPa) (100 kPa = 1 bar)
Inch pounds (in. lbs.)	x 0.113	= newtons-meters (N•m)
Foot pounds (ft. lbs.)	x 1.356	= newtons-meters (N•m)
Centimeters (cm)	x .394	= inches (in.)
Millimeters (mm)	x .0394	= inches (in.)
Centimeters (cm)	x .0328	= feet (ft.)
Hectares (ha)	x 2.469	= acres
Kilometers per hour (kmph)	x 0.621	= miles per hour (mph)
Kilograms (kg)	x 2.208	= pounds (lbs.)
Liters (l)	x 0.028	= bushels (bu.)
Liters (l)	x 0.264	= gallons (gal.)
Kilopascals (kPa) (100 kPa = 1 bar)	x 0.145	= pounds per square inch (psi)
Newtons-meters (N•m)	x 8.85	= inch pounds (in. lbs.)
Newtons-meters (N•m)	x 0.738	= foot pounds (ft. lbs.)

MACHINE OPERATION

TRANSPORTING THE PLANTER



WARNING: Always make sure safety/warning lights, reflectors and SMV emblem are in place and visible prior to transporting the machine on public roads. In this regard, check and comply with all federal, state/provincial and local regulations.



DANGER: Always install all safety lockups before transporting the planter.

PLANTING SPEED

Planters are designed to operate within a speed range of 2 to 8 MPH. See “Rate Charts”. Variations in ground speed will produce variations in rates. Finger pickup seed meter populations will tend to be disproportionately higher at high ground speeds.

NOTE: Due to a multitude of variables, seed spacing can be adversely affected at speeds above 5.5 MPH.

FIELD TEST

With any change of field and/or planting conditions, seed size or planter adjustment, we recommend a field test be made to ensure proper seed placement and operation of row units. See “Rate Charts”, “Checking Seed Population” and “Checking Granular Chemical Application Rate” at the end of this section.

- Check the planter for fore to aft and lateral level operation. See “Leveling The Planter”.
- Check **all** row units to be certain they are running level. When planting, the row unit parallel arms should be approximately parallel to the ground.
- Check row markers for proper operation and adjustment. See “Marker Adjustment”, “Marker Speed Adjustment” and “Marker Operation”.
- Check for proper application rates and placement of granular chemicals on **all** rows. See “Checking Granular Chemical Application Rate”.
- Check for desired depth placement and seed population on **all** rows. See “Checking Seed Population”.

After the planter has been field tested, reinspect the machine.

- Hoses And Fittings
- Bolts And Nuts
- Cotter Pins And Roll Pins

MACHINE OPERATION

ELECTRONIC SEED MONITOR SYSTEM

The electronic seed monitor system consists of a console, which is mounted on the tractor; seed tubes with sensors, one of which is installed in each planter row unit; and a planter harness (harness, Y-connector and/or extension cable where applicable), which connects the individual seed tube sensors to the console.

The monitor system is powered by the tractor battery (requires 12 volts DC). The console receives information from each of the sensors and translates this information for the operator, to let him know whether or not all rows are planting.

Located on the bottom of the monitor console is the sound alarm which is equipped with an adjustable sound baffle.

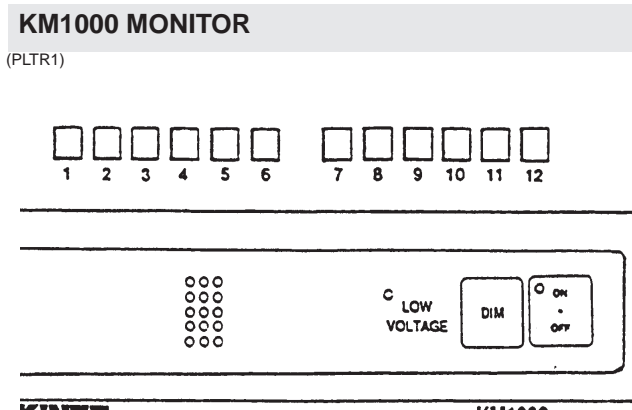

STEP 1 Turn the console ON by pressing the ON/OFF switch.

Each time the console is powered up it performs a sensor check and self-check. All row indicator lamps are turned on, the alarm sounds momentarily and then the console enters the operate mode. If a row indicator lamp does not come on when the console is powered up, it indicates that a problem exists with either the sensor, planter harness or a burned out row indicator lamp. See Troubleshooting in the Maintenance Section of this manual.

STEP 2 Begin planting and observe the row indicator lamps.

All indicator lamps should be flashing at approximately the same rate. If one of the row lamps is flashing at a slower rate than the others it would indicate that row is planting at a slower rate and it should be checked for proper seed population. The monitor

continuously checks for seed flow while planting, as indicated by the flashing row indicator lamps on the console. If any planter unit seed sensor is not detecting seeds, the alarm will sound continuously and the row indicator lamp corresponding to the planter row unit will stop flashing. When this happens, stop planting and check to see what is wrong with the row unit.

STEP 3 Lift the planter at the end of the row. When the seed flow stops in all planter units, the alarm will sound and all row indicator lamps will stop flashing. After approximately 2-4 seconds the alarm will stop sounding.

The intensity of the Row Indicator Lamps can be controlled by pressing and holding the switch labeled DIM. To set the intensity, press and hold the DIM switch until the lamps are at the desired intensity and then release the switch. Holding the DIM switch will cause the intensity to decrease to its lowest level and then increase to its maximum level. This cycle will continue as long as the switch is depressed. When the console is turned OFF and then ON the row lamp intensity will return to maximum.

If you are only using a portion of the number of rows on your planter, the alarm can be silenced by disconnecting the seed sensors of the unused rows (Disconnect Interplant® rows at "Y" harness.) and turning the monitor OFF then back ON. The monitor will then ignore these unused rows and monitor the other rows normally.

When disabling planter rows, the monitor may look at the system as a different planter setup. Example: If you have an 8 row planter and you disable the right four rows (for planting point rows, etc.) by unplugging the seed sensors and turning the monitor OFF and back to ON, the monitor will look at it as a 4 row planter and shift the row indicator lamps to the center four positions. Therefore, planter row 1 will be indicated on the monitor as row 3, planter row 2 as row 4, etc. Row lamps 1, 2, 7 and 8 will be off.

If you disable the left four rows (planter rows 1, 2, 3 and 4) the monitor will operate normally as an 8 row system. Row indicators 1, 2, 3 and 4 will be off.

MACHINE OPERATION

10/96

KM1000 Bezel Decal Selection Chart

NO. ROWS	BEZEL DECAL	ROW LAMPS
4	12	 1 2 3 4 5 6 7 8 9 10 11 12
6	6	 1 2 3 4 5 6
8	16	 1 2 3 4 5 6 7 8 9 10 11 12 13 14 15 16
*8	16	 1 2 3 4 5 6 7 8 9 10 11 12 13 14 15 16
10	12	 1 2 3 4 5 6 7 8 9 10 11 12
12	12	 1 2 3 4 5 6 7 8 9 10 11 12
*12	12	 1 2 3 4 5 6 7 8 9 10 11 12
16	16	 1 2 3 4 5 6 7 8 9 10 11 12 13 14 15 16
*4 & 3 Solid Interplant®	16	 1 2 3 4 5 6 7 8 9 10 11 12 13 14 15 16
*6 & 3 Skip Row Interplant®	16	 1 2 3 4 5 6 7 8 9 10 11 12 13 14 15 16
*6 & 5 Solid Interplant®	16	 1 2 3 4 5 6 7 8 9 10 11 12 13 14 15 16
*8 & 5 Skip Row Interplant®	16	 1 2 3 4 5 6 7 8 9 10 11 12 13 14 15 16
*8 & 7 Solid Interplant®	16	 1 2 3 4 5 6 7 8 9 10 11 12 13 14 15 16

Row lamp indicates planter row in use.

Row lamp not used.

* With Y-connector.

NOTE: Interplant® diagrams assume that first Interplant® row is connected to row 1 of harness and Interplant® harness is connected to R.H. half of Y-connector.

MACHINE OPERATION

KM3000 MONITOR

D-0841-0001(PLTR2)

Upper Display

Pressure Sensitive Switches

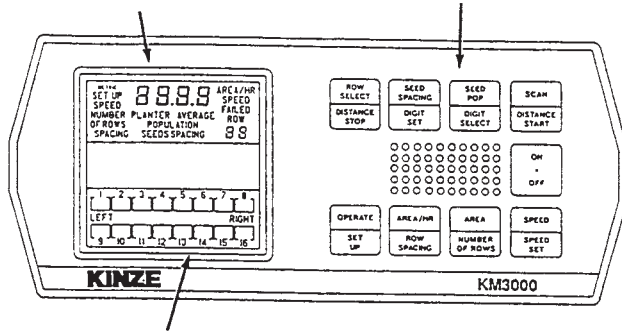

Lower Display

The KM3000 console may be equipped with one of two optional distance sensors; a radar sensor which is mounted on the tractor or a pulse wheel (magnetic distance sensor) which is installed on the planter drive.

The operator's controls on the front panel of the console consist of nine pressure sensitive switches. Eight of the nine switches are dual function switches, performing one function during the OPERATE MODE and another function during the SET UP MODE. All switch functions are color coded to define between the OPERATE and SET UP modes. The upper half of each dual function switch is olive brown in color and contains the Operate functions. The lower half of each dual function switch is tan in color and contains the Set Up functions.

NOTE: The KM3000 is shipped from the factory setup for use with American measures. To convert the console to Metric measures, cut the wire loop (red wire) adjacent to the signal cable on the back of the console and tape the ends of the cut wire to prevent the two ends making contact with each other or the vehicle.

STEP 1 Turn console ON by pressing the ON-OFF switch. Note that the upper display shows random segments for a short time then sequences through all entered SET UP constants (SPEED, NUMBER OF ROWS and ROW SPACING). If the constants are not valid the alarm will sound for approximately four seconds and the monitor will enter the SET UP mode. See "Entering Constants". If all constants are valid (as previously entered) the alarm will sound momentarily and the monitor will enter the OPERATE mode.

NOTE: Monitor will not go from "SET UP" to "OPERATE" unless the planter harness is connected.

STEP 2 Select the desired OPERATE function to be displayed by pressing the labeled switch.

In the **ROW SELECT** mode a specific row can be selected and continuously monitored.

SEED SPACING displays the seed spacing of each planter row in inches or centimeters.

SEED POP displays the seed population of each planter row in thousands of seeds per acre or hectare.

In the **SCAN** mode the display will sequence through all planter rows. The display message will be SEED POP or SEED SPACING as previously selected. With SEED POP selected, after the population for the highest planter row number is displayed, the average population for the total planter is shown. With SEED SPACING selected, after the seed spacing for the highest planter row number is displayed, the average seed spacing for the total planter is shown.

AREA/HR displays the predicted area in acres or hectares that will be covered in the next hour if the same planting rate is maintained. This prediction is based on the last 10 seconds of operation.

AREA displays the actual area covered in acres or hectares since the last reset. To reset area to .0, press and hold the AREA switch for approximately 5 seconds.

SPEED displays current vehicle ground speed in MPH or KmPH.

A row failure will be indicated by the FAILED ROW number being displayed in the lower right hand corner of the upper display, the corresponding segment in the lower display will be blank, and the alarm will sound continuously. Failures of more than one row will be indicated by the FAILED ROW number in the upper display sequencing through all failed rows, the corresponding segments of all failed rows in the lower display will be blank, and the alarm will sound continuously. When you lift your planter at the end of a row or stop in the field and seed flow stops in all planter units, the alarm will sound for approximately four seconds and all row indicator segments (lower display) will stop flashing. The upper display will show the FAILED ROW message and will sequence through all planter row numbers.

In the all row failure mode or immediately following power up, the operate functions (population, seed spacing and area) can be displayed by pressing the touch switch labeled with the desired function. This display condition will remain for one minute after the last time a switch is pressed or until seeds are detected by the seed sensors.

MACHINE OPERATION

A ground speed failure will be indicated by the SPEED FAILED message being displayed in the upper display. To continue using the monitor system until a replacement ground speed sensor is obtained, disconnect the ground speed sensor cable, enter the SET UP mode and enter your normal planting speed in MPH or KmPH in place of the SPEED SET calibration number. **IMPORTANT:** The accuracy of the POPULATION, SEED SPACING and AREA readouts will depend on the vehicle ground speed. If you do not drive at the speed entered in SPEED SET memory these functions will not be accurate. AREA will not accumulate in this mode.

IMPORTANT: Under normal use the monitor will accumulate area whenever there is seed flow in at least one seed sensor. In the all rows failed condition, such as when turning around at the end of the field, the area accumulation will stop.

The monitor can be used to count seeds in a selected row by performing the following:

1. Place console in SET UP mode. (Before performing Step 2 make sure you have recorded the SPEED constant. See SPEED in "Entering Constants".)
2. Set the SPEED constant to 0000. This can be done by manually setting each digit to zero using the DIGIT SELECT and DIGIT SET switches or by pressing and holding the SPEED SET switch for approximately 5 seconds.
3. Enter the OPERATE mode by pressing the OPERATE switch.
4. Press and release the ROW SELECT switch until the desired planter row number is displayed in the lower right corner of the upper display. The monitor will now show seed count for the selected row.

To reset the display to zero and continue to monitor the same row unit, press the SCAN switch then the ROW SELECT.

To select another row unit, press the ROW SELECT switch until the desired planter row number is displayed. Each time the ROW SELECT switch is pressed the row number will be incremented one unit and the four digit display will be reset to zero.

IMPORTANT: To return to normal operation, enter the SET UP mode and re-enter the SPEED constant.

The lower visual display contains up to sixteen segments with each one corresponding to a planter row unit. When the monitor is turned on the console senses the number of seed sensors connected to the planter harness and activates a segment for each one. The segment flashes dark each time a seed is detected by the seed sensor. If up to 16 seed sensors are sensed the display will show segments for all sensors all the time. If more than 16 (17-32) seed sensors are sensed, then the display is split and up to 16 sensors are shown for the LEFT and RIGHT side of the planter.

EXAMPLE: If a 24 row planter is being used and the display message LEFT is on, the segments are showing seed flow for planter rows 1 through 12. When the display message RIGHT is on, the segments are showing seed flow for planter rows 13 through 24. When the RIGHT planter half is shown, the segment numbers 1 through 12 will represent planter rows 13 through 24 (segment 1 is planter row 13, segment 2 is row 14, up to segment 12 which is row 24).

ENTERING CONSTANTS (KM3000 Only)

Upon initial power-up or whenever memory is lost the following three constants must be entered before the system will enter the "operate" mode. The following examples are for an 8 row planter with 30" row spacing.

1. ROW SPACING - *The distance between the rows on your planter.*

Press the "row spacing" switch. The upper display will show "set up", "row spacing" and "000.0".

Press the "digit select" switch (a short alarm burst will be heard each time the switch activates) until the second "0" to the left of the decimal point is flashing. Press the "digit set" switch until a "3" is shown in this location: 030.0.

NOTE: Holding the "digit set" switch will cause the digit to increment from 0 through 9.

MACHINE OPERATION

2. NUMBER OF ROWS - *The number of active rows on your planter. (Example for 8 row planter)*

Press the “number of rows” switch. The upper display will show “set up”, “number of rows” and “00”.

Press the “digit select” switch until the right hand “0” is flashing.

Press the “digit set” switch until an 8 is shown in this location: 08.

3. SPEED - *A number that is the result of the speed calibration procedure. Used with either radar or magnetic distance sensors.*

The speed set calibration number matches the console to the ground speed sensor when calibrated over a specified measured distance. When the calibration procedure is completed and the speed set constant established, the value should be written down and retained in the event battery voltage is removed from the console and the information in memory is lost. In this event, the constant may be re-entered manually using the “digit select” and “digit set” switches. The speed set calibration procedure must be repeated and new speed set number established if the radar or magnetic distance sensor mounting is changed for any reason.

NOTE: When obtaining the following speed set number, actual in-field conditions should be simulated as close as possible.

- A. Measure an accurate 400 foot (150 meter) in-field course, preferably on level ground. Mark the “start” and “finish” of the course so it will be plainly visible from the cab as you drive past.
- B. With the upper display showing messages “set up” and “speed” and the four digit display showing all zeros (to reset four digit display to zeros, press and hold the “speed set” switch for approximately 5 seconds), drive up to the marked course at normal planting speed.
- C. When even with the “start” marker, press the “distance start” switch. Four dashes will appear on the console display.
- D. Drive at a steady speed through the entire course. When even with the “finish” marker, press the “distance stop” switch.
- E. The speed set number will be displayed. Record this number for future reference.

IMPORTANT: This procedure may have to be repeated after performing the Radar Vibration Test. See Radar Vibration Test.

NOTE: The accuracy of the area computations, population, seed spacing and vehicle ground speed readout are dependent upon the accuracy of the operator entered constants. Use care when determining the constants which describe your planter.

**RADAR VIBRATION TEST
(KM3000 With Radar Sensor Only)**

To check for vibration, start vehicle engine and slowly increase engine RPM (while watching the ground speed readout) to approximately 1800 RPM. If the ground speed readings are above zero, the radar sensor must be mounted in an alternate, more stable location.

SPEED SET NUMBER _____

MACHINE OPERATION

CHECKING SEED POPULATION

1. Tie up one or more sets of closing wheels by running a light chain or rubber tarp strap between the hopper support panel and closing wheels. It may be necessary to decrease closing wheel arm spring tension.

L0069(PLTR10)

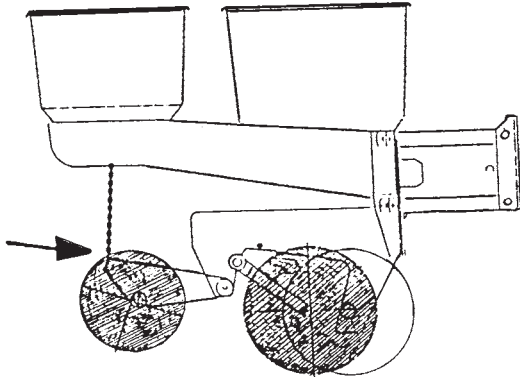

2. Plant a short distance and check to see if seed is visible in the seed trench. Adjust planting depth to a shallower setting if seed is not visible and recheck.

72359-108

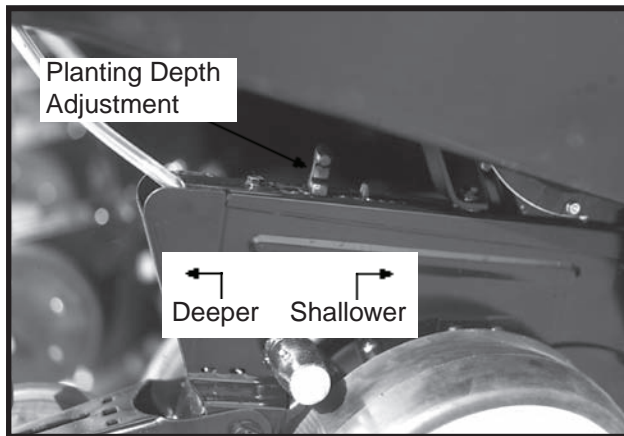

3. Measure $\frac{1}{1000}$ of an acre. See chart for correct distance for row width being planted. For example, if planting 30" rows $\frac{1}{1000}$ of an acre would be 17' 5".

LENGTH OF ROW IN FEET AND INCHES				
Fraction Of Acre	Row Width			
	30"	36"	38"	40"
$\frac{1}{1000}$	17' 5"	14' 6"	13' 10"	13' 1"

NOTE: When planting with closing wheels raised and planting depth set shallow, seeds may bounce or roll affecting seed spacing accuracy.

4. Count seeds in measured distance.
5. Multiply the number of seeds placed in the $\frac{1}{1000}$ of an acre by 1000. This will give you total population.

EXAMPLE: With 30" row spacing 17' 5" equals $\frac{1}{1000}$ acre.

26 Seeds

Counted	x	1000	=	26,000 Seeds Per Acre
---------	---	------	---	-----------------------

Seed count can be affected by drive ratio between drive wheel and seed meter, tire pressure and/or seed meter malfunction.

If seed check shows the average distance between seeds in inches is significantly different than the seed rate chart indicates, first check drive ratio between drive wheel and seed meter. Check drive wheel air pressure, check for incorrect sprocket(s) in drive line and check drive and driven sprockets on transmission for proper selection.

Second, check for seed meter malfunction. For example, if spacing between kernels of corn at the transmission setting being used is 8" and a gap of 16" is observed, a finger has lost its seed and not functioned properly. If two seeds are found within a short distance of each other, the finger has metered two seeds instead of one.

See "Finger Pickup Seed Meter Troubleshooting" and/or "Brush-Type Seed Meter Troubleshooting" in the Maintenance Section of this manual.

MACHINE OPERATION

Determining Pounds Per Acre (Brush-Type Seed Meter)

To determine pounds per acre:

Seeds Per Acre On Chart	÷	Seeds Per Pound From Seed Tag On Bag	=	Pounds Per Acre
-------------------------------	---	---	---	-----------------------

To determine bushels per acre:

Pounds Per Acre	÷	Unit Weight Of Seed	=	Bushels Per Acre
--------------------	---	------------------------	---	---------------------

The unit weight of:

- 1 Bushel Soybeans = 60 Pounds
- 1 Bushel Milo = 56 Pounds
- 1 Bushel Cotton = 32 Pounds

If seeds per pound information is not available the following is an average:

- 2,600 seeds per pound for medium size soybeans
- 15,000 seeds per pound for medium size milo
- 4,500 seeds per pound for medium size cotton

If seed check shows planting rate is significantly different than seed rate chart shows or if a particular meter is not planting accurately, see "Brush-Type Seed Meter Maintenance" and "Brush-Type Seed Meter Troubleshooting".

CHECKING GRANULAR CHEMICAL APPLICATION RATE

Many things can affect the rate of delivery of granular chemicals such as temperature, humidity, speed, ground conditions, flowability of different material or any obstruction in the meter.

A field check is important to determine correct application rates.

72359-105

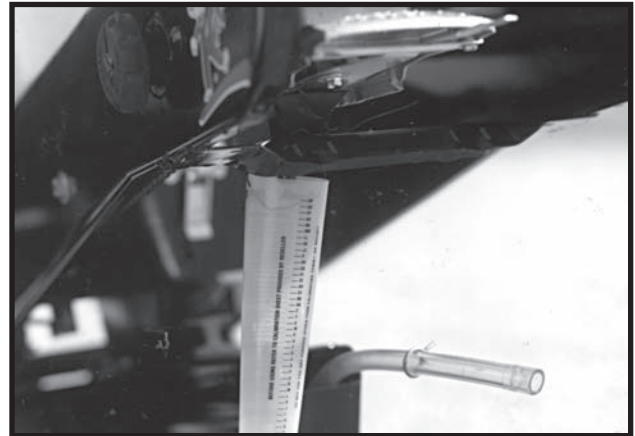

To check, fill insecticide and/or herbicide hoppers. Attach a calibrated vial to each granular chemical meter. Lower the planter and proceed as follows:

NOTE: It is not necessary for seed meter clutch to be engaged during test. Disengage clutch to avoid dropping seed.

Drive 1,320 feet at planting speed. Weigh the chemical in ounces that was caught in one vial. Multiply that amount by the factor shown to determine pounds per acre.

LBS. PER ACRE FACTOR FOR GIVEN ROW WIDTH	
Row Width	Factor
30"	0.83
36"	0.69
38"	0.65
40"	0.62

EXAMPLE: You are planting 30" rows. You have planted for 1,320 feet at the desired planting speed. You caught 12.0 ounces of chemical in one vial. 12.0 ounces times 0.83 equals 9.96 pounds per acre.

NOTE: It is important to check calibration of all rows.

Metering Gate

Use the metering gate setting for distributing insecticide or herbicide as a starting point. The charts are based on a 5 miles per hour planting speed. For speeds faster than 5 miles per hour a higher gate setting should be used. For speeds slower than 5 miles per hour a lower gate setting should be used.



WARNING: Agricultural chemicals can be dangerous if not selected and handled with care. Always read and follow directions supplied by the chemical manufacturer.

MACHINE OPERATION

GENERAL PLANTING RATE INFORMATION

These planting rate charts are applicable to KINZE® Model 2100 Stack Folding planters. See “Tire Pressure” for recommended tire pressures.

Not all row spacings listed are applicable to all size planters.

IMPORTANT: The sprocket combinations listed in these charts are best for average conditions. Changes in sprocket combinations may be required to obtain desired planting population. TO PREVENT PLANTING MISCALCULATIONS, MAKE FIELD CHECKS TO BE SURE YOU ARE PLANTING AT THE DESIRED RATE.

The size and shape of seed may affect the planting rate.

Finger Pickup Seed Meter (Corn, Oil Sunflower)

Larger grades will generally plant more accurately at the high end of the ground speed range than smaller grades. Higher than optimum speeds may result in population rate increase or higher incidence of doubles, particularly with small seed. Medium round corn seed is most desirable for planting accuracy at optimum speed. Only No. 3 and No. 4 oil sunflower seed are recommended for planting accuracy at optimum speed.

NOTE: Seed additives, added to the seed in the hopper, may adversely affect performance of the finger pickup seed meter and accelerate wear. See “Finger Pickup Seed Meter” in the Row Unit Operation section.

Brush-Type Seed Meter (Soybean, Milo/Grain Sorghum, Acid-Delinted Cotton)

Rate charts are given in seeds per acre as well as seed spacing in inches rounded to the nearest tenth of an inch. Because of the large range in seed size, pounds per acre is not a suggested method of selecting transmission settings. When using smaller size seeds it may appear the pounds per acre is below what was expected and vice versa on large seed. To determine pounds per acre, use the formula given in “Determining Pounds Per Acre (Brush-Type Seed Meter)” in the “Checking Seed Population” section of this manual.

NOTE: Due to a multitude of variables, seed spacing can be adversely affected at speeds above 5.5 MPH.

In some cases a **Half Rate (2 To 1) Drive Reduction Package** may be required to obtain the desired population and seed spacing.

NOTE: Use of the Half Rate (2 to 1) Drive Reduction Package will reduce the planter transmission speed. The seeding rate will be approximately 50% of the chart reading when using the Half Rate (2 to 1) Drive Reduction Package. Planting speed can affect actual seeding rate. Make a field check and adjust setting in the transmissions as needed to obtain the desired seed drop.

EXAMPLE: 30" row spacing using 60 cell seed disc in brush-type seed meter.
 $80,928 \div 2 = 40,464$ Population
 $2.6'' \text{ Seed Spacing} \times 2 = 5.2'' \text{ Seed Spacing}$

81014-2

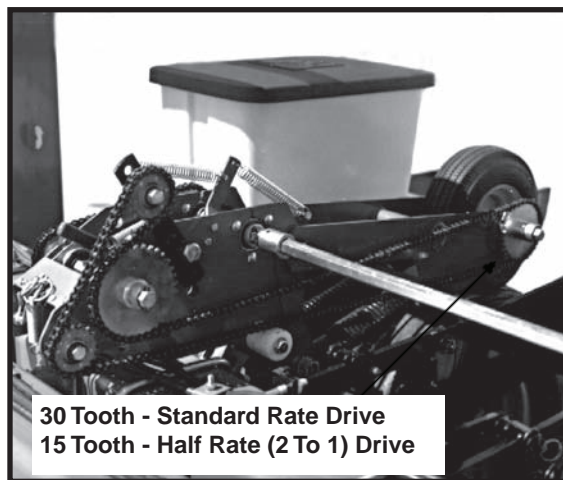

MACHINE OPERATION

PLANTING RATES FOR FINGER PICKUP SEED METERS APPROXIMATE SEEDS/ACRE FOR VARIOUS ROW WIDTHS

30" Rows	36" Rows	38" Rows	40" Rows	Transmission Sprockets		Recomm. Speed Range (MPH)	Average Seed Spacing In Inches
				Drive	Driven		
16,186	13,488	12,778	12,139	17	28	4 to 6	12.9
16,785	13,988	13,251	12,589	17	27	4 to 6	12.5
17,431	14,526	13,761	13,073	17	26	4 to 6	12.0
18,090	15,075	14,281	13,567	19	28	4 to 6	11.6
18,128	15,107	14,312	13,596	17	25	4 to 6	11.5
18,760	15,633	14,810	14,070	19	27	4 to 6	11.1
18,883	15,736	14,908	14,162	17	24	4 to 6	11.1
19,481	16,234	15,380	14,611	19	26	4 to 6	10.7
19,704	16,420	15,556	14,778	17	23	4 to 6	10.6
20,261	16,884	15,995	15,195	19	25	4 to 6	10.3
21,104	17,587	16,662	15,829	19	24	4 to 6	9.9
21,898	18,249	17,288	16,424	23	28	4 to 6	9.5
22,022	18,352	17,386	16,517	19	23	4 to 6	9.5
22,709	18,924	17,928	17,032	23	27	4 to 6	9.2
22,850	19,042	18,040	17,138	24	28	4 to 6	9.2
23,583	19,652	18,618	17,687	23	26	4 to 6	8.9
23,697	19,747	18,708	17,772	24	27	4 to 6	8.8
23,802	19,835	18,791	17,852	25	28	4 to 6	8.8
23,853	19,877	18,831	17,889	17	19	4 to 6	8.8
24,526	20,438	19,363	18,395	23	25	4 to 6	8.5
24,608	20,507	19,427	18,456	24	26	4 to 6	8.5
24,684	20,570	19,487	18,513	25	27	4 to 6	8.5
24,755	20,629	19,543	18,566	26	28	4 to 6	8.4
25,548	21,290	20,169	19,161	23	24	4 to 6	8.2
25,592	21,327	20,205	19,194	24	25	4 to 6	8.2
25,633	21,361	20,237	19,225	25	26	4 to 6	8.2
25,671	21,393	20,267	19,254	26	27	4 to 6	8.1
25,707	21,422	20,295	19,280	27	28	4 to 6	8.1
26,659	22,216	21,046	19,994	23	23	4 to 6	7.8
27,646	23,038	21,826	20,735	28	27	4 to 6	7.6
27,684	23,070	21,856	20,763	27	26	4 to 6	7.6
27,770	23,141	21,923	20,827	25	24	4 to 6	7.5
27,818	23,181	21,961	20,863	24	23	4 to 6	7.5
28,709	23,924	22,665	21,532	28	26	4 to 6	7.3
28,791	23,993	22,730	21,594	27	25	4 to 6	7.3
28,977	24,147	22,876	21,733	25	23	4 to 6	7.2
29,795	24,829	23,522	22,346	19	17	4 to 6	7.0
29,858	24,881	23,572	22,393	28	25	4 to 6	7.0
29,991	24,993	23,677	22,493	27	24	4 to 6	7.0
30,136	25,113	23,792	22,602	26	23	4 to 6	7.0
31,102	25,918	24,554	23,326	28	24	3 to 6	6.7
31,295	26,079	24,707	23,471	27	23	3 to 6	6.7
32,271	26,893	25,477	24,203	23	19	3 to 5.5	6.5
32,454	27,045	25,622	24,341	28	23	3 to 5.5	6.5
33,674	28,062	26,585	25,256	24	19	3 to 5.5	6.2
35,077	29,231	27,693	26,308	25	19	3 to 5	6.0
36,068	30,056	28,474	27,051	23	17	2 to 5	5.8
36,480	30,400	28,800	27,360	26	19	3 to 5	5.7
37,636	31,363	29,713	28,227	24	17	3 to 5	5.6
37,883	31,570	29,908	28,413	27	19	3 to 5	5.5
39,204	32,670	30,951	29,403	25	17	3 to 4.5	5.3
39,287	32,739	31,016	29,465	28	19	3 to 4.5	5.3
40,772	33,977	32,189	30,579	26	17	3 to 4.5	5.1
42,340	35,284	33,427	31,755	27	17	3 to 4.5	4.9
43,908	36,590	34,665	32,931	28	17	3 to 4.5	4.8

IMPORTANT: See "General Planting Rate Information" and "Checking Seed Population" pages for additional information. Always check seed population in the field to ensure planting rates are correct.

MACHINE OPERATION

Z214/RH

PLANTING RATES FOR BRUSH-TYPE SEED METERS

APPROXIMATE SEEDS/ACRE FOR VARIOUS ROW WIDTHS

Transmission Sprockets		60 Cell Soybean Or High Rate Milo/ Grain Sorghum				Average Seed Spacing In Inches	48 Cell Specialty Soybean Or High Rate Acid-Delinted Cotton				Average Seed Spacing In Inches	Speed Range (MPH)
Drive	Driven	30" Rows	36" Rows	38" Rows	40" Rows		30" Rows	36" Rows	38" Rows	40" Rows		
17	28	80,928	67,440	63,891	60,696	2.6	64,742	53,952	51,113	48,557	3.2	2 to 8
17	27	83,926	69,938	66,257	62,944	2.5	67,141	55,950	53,006	50,355	3.1	2 to 8
17	26	87,154	72,628	68,805	65,365	2.4	69,723	58,102	55,044	52,292	3.0	2 to 8
19	28	90,449	75,374	71,407	67,837	2.3	72,359	60,299	57,126	54,270	2.9	2 to 8
19	27	93,799	78,166	74,052	70,349	2.2	75,039	62,533	59,242	56,279	2.8	2 to 8
17	24	94,416	78,680	74,539	70,812	2.2	75,533	62,944	59,631	56,650	2.8	2 to 8
17	23	98,521	82,101	77,780	73,891	2.1	78,817	65,681	62,224	59,113	2.7	2 to 8
19	25	101,303	84,419	79,976	75,977	2.1	81,042	67,535	63,981	60,782	2.6	2 to 8
19	24	105,524	87,937	83,309	79,143	2.0	84,419	70,350	66,647	63,314	2.5	2 to 8
23	28	109,491	91,243	86,440	82,118	1.9	87,593	72,994	69,152	65,694	2.4	2 to 8
19	23	110,112	91,760	86,931	82,584	1.9	88,090	73,408	69,545	66,067	2.4	2 to 8
24	28	114,252	95,210	90,199	85,689	1.8	91,402	76,168	72,159	68,551	2.3	2 to 8
24	27	118,483	98,736	93,539	88,862	1.8	94,786	78,989	74,831	71,090	2.2	2 to 8
17	19	119,263	99,386	94,155	89,447	1.8	95,410	79,509	75,324	71,558	2.2	2 to 8
24	26	123,040	102,534	97,137	92,280	1.7	98,432	82,027	77,710	73,824	2.1	2 to 8
26	28	123,773	103,144	97,715	92,829	1.7	99,018	82,515	78,172	74,263	2.1	2 to 8
24	25	127,962	106,635	101,023	95,971	1.6	102,370	85,308	80,818	76,777	2.0	2 to 8
26	27	128,357	106,964	101,334	96,268	1.6	102,686	85,571	81,067	77,014	2.0	2 to 8
23	23	133,294	111,078	105,232	99,970	1.6	106,635	88,862	84,186	79,976	2.0	2 to 8
27	26	138,420	115,350	109,279	103,815	1.5	110,736	92,280	87,423	83,052	1.9	2 to 8
24	23	139,089	115,907	109,807	104,317	1.5	111,271	92,726	87,846	83,454	1.9	2 to 8
25	23	144,884	120,737	114,382	108,663	1.4	115,907	96,590	91,506	86,930	1.8	2 to 8
19	17	148,975	124,146	117,612	111,731	1.4	119,180	99,317	94,090	89,385	1.8	2 to 8
27	24	149,955	124,963	118,386	112,466	1.4	119,964	99,970	94,709	89,973	1.7	2 to 8
28	24	155,509	129,591	122,770	116,632	1.3	124,407	103,673	98,216	93,306	1.7	2 to 8
23	19	161,355	134,463	127,386	121,017	1.3	129,084	107,570	101,909	96,814	1.6	2 to 8
28	23	162,270	135,225	128,108	121,703	1.3	129,816	108,180	102,483	97,362	1.6	2 to 8
24	19	168,371	140,309	132,924	126,278	1.2	134,696	112,247	106,339	101,022	1.6	2 to 8
25	19	175,386	146,155	138,463	131,540	1.2	140,309	116,924	110,770	105,232	1.5	2 to 8
23	17	180,338	150,282	142,372	135,254	1.2	144,270	120,226	113,898	108,203	1.5	2 to 8
26	19	182,402	152,001	144,001	136,801	1.1	145,922	121,601	115,201	109,441	1.4	2 to 7
27	19	189,407	157,848	148,540	142,063	1.1	151,534	126,278	118,832	113,650	1.4	2 to 7
28	19	196,433	163,694	155,078	147,325	1.1	157,146	130,955	124,062	117,860	1.3	2 to 7
26	17	203,861	169,884	160,943	152,896	1.0	163,089	135,907	128,754	122,317	1.3	2 to 7
27	17	211,702	176,418	167,133	158,776	0.9	169,362	141,134	133,706	127,021	1.2	2 to 7
28	17	219,542	182,952	173,323	164,657	0.9	175,634	146,362	138,658	131,726	1.2	2 to 7

IMPORTANT: See “General Planting Rate Information” and “Checking Seed Population” pages for additional information.

NOTE: When using the Half Rate (2 to 1) Drive Reduction Package, rates will be approximately 50% of given numbers.

IMPORTANT: Always check seed population in the field to ensure planting rates are correct.

MACHINE OPERATION

RH/Z215

PLANTING RATES FOR BRUSH-TYPE SEED METERS (Continued)

APPROXIMATE SEEDS/ACRE FOR VARIOUS ROW WIDTHS

Transmission Sprockets		36 Cell Acid-Delinted Large Cotton				Average Seed Spacing In Inches	30 Cell Milo/Grain Sorghum Or Acid-Delinted Cotton				Average Seed Spacing In Inches	Speed Range (MPH)
Drive	Driven	30" Rows	36" Rows	38" Rows	40" Rows		30" Rows	36" Rows	38" Rows	40" Rows		
17	28	48,557	40,464	38,335	36,418	4.3	40,464	33,720	31,945	30,348	5.2	2 to 8
17	27	50,356	41,963	39,754	37,766	4.2	41,963	34,969	33,129	31,472	5.0	2 to 8
17	26	52,292	43,577	41,283	39,219	4.0	43,577	36,314	34,403	32,683	4.8	2 to 8
19	28	54,269	45,224	42,844	40,702	3.9	45,225	37,687	35,704	33,918	4.6	2 to 8
19	27	56,279	46,900	44,431	42,209	3.7	46,900	39,083	37,026	35,175	4.5	2 to 8
17	24	56,650	47,208	44,723	42,487	3.7	47,208	39,340	37,270	35,406	4.4	2 to 8
17	23	59,113	49,261	46,668	44,335	3.5	49,261	41,051	38,890	36,946	4.2	2 to 8
19	25	60,782	50,651	47,986	45,586	3.5	50,652	42,210	39,988	37,989	4.1	2 to 8
19	24	63,314	52,762	49,985	47,486	3.3	52,762	43,968	41,654	39,572	4.0	2 to 8
23	28	65,695	54,746	51,864	49,271	3.2	54,746	45,621	43,220	41,059	3.8	2 to 8
19	23	66,067	55,056	52,159	49,550	3.2	55,056	45,880	43,465	41,292	3.8	2 to 8
24	28	68,551	57,126	54,119	51,413	3.0	57,126	47,605	45,099	42,844	3.7	2 to 8
24	27	71,090	59,242	56,123	53,317	2.9	59,242	49,368	46,770	44,431	3.5	2 to 8
17	19	71,558	59,632	56,493	53,668	2.9	59,631	49,693	47,077	44,724	3.5	2 to 8
24	26	73,824	61,520	58,282	55,368	2.8	61,520	51,267	48,569	46,140	3.4	2 to 8
26	28	74,264	61,886	58,629	55,697	2.8	61,886	51,572	48,858	46,415	3.4	2 to 8
24	25	76,772	63,981	60,614	57,583	2.7	63,981	53,317	50,511	47,986	3.3	2 to 8
26	27	77,014	64,178	60,800	57,761	2.7	64,178	53,482	50,667	48,134	3.3	2 to 8
23	23	79,976	66,647	63,139	59,982	2.6	66,647	55,539	52,616	49,985	3.1	2 to 8
27	26	83,052	69,210	65,567	62,289	2.5	69,210	57,675	54,640	51,908	3.0	2 to 8
24	23	83,453	69,544	65,884	62,590	2.5	69,544	57,954	54,904	52,158	3.0	2 to 8
25	23	86,930	72,442	68,629	65,198	2.4	72,442	60,368	57,191	54,332	2.9	2 to 8
19	17	89,385	74,488	70,567	67,039	2.3	74,488	62,073	58,809	55,866	2.8	2 to 8
27	24	89,973	74,978	71,032	67,480	2.3	74,978	62,481	59,193	56,233	2.8	2 to 8
28	24	93,305	77,755	73,662	69,979	2.2	77,755	64,796	61,385	58,316	2.7	2 to 8
23	19	96,813	80,678	76,432	72,610	2.2	80,678	67,231	63,693	60,508	2.6	2 to 8
28	23	97,362	81,135	76,864	73,022	2.1	81,135	67,613	64,054	60,851	2.6	2 to 8
24	19	101,023	84,185	79,754	75,767	2.1	84,185	70,155	66,462	63,139	2.5	2 to 8
25	19	105,232	87,693	83,078	78,924	2.0	87,693	73,078	69,231	65,770	2.4	2 to 8
23	17	108,233	90,169	85,423	81,152	1.9	90,169	75,141	71,186	67,627	2.3	2 to 8
26	19	109,441	91,201	86,401	82,081	1.9	91,201	76,001	72,001	68,401	2.3	2 to 7
27	19	113,650	94,709	89,124	85,238	1.8	94,709	78,924	74,770	71,031	2.2	2 to 7
28	19	117,860	98,216	93,047	88,395	1.8	98,216	81,847	77,539	73,662	2.1	2 to 7
26	17	122,317	101,930	96,566	91,738	1.7	101,930	84,942	80,471	76,448	2.1	2 to 7
27	17	127,021	105,851	100,280	95,266	1.6	105,851	88,209	83,566	79,388	2.0	2 to 7
28	17	131,725	109,771	103,994	98,794	1.6	109,771	91,476	86,661	82,328	1.9	2 to 7

IMPORTANT: See "General Planting Rate Information" and "Checking Seed Population" pages for additional information.

NOTE: When using the Half Rate (2 to 1) Drive Reduction Package, rates will be approximately 50% of given numbers.

IMPORTANT: Always check seed population in the field to ensure planting rates are correct.

MACHINE OPERATION

PLANTING RATES FOR BRUSH-TYPE SEED METERS (Continued) APPROXIMATE HILLS/ACRE FOR VARIOUS ROW WIDTHS

Due to variations in cotton seed size, meters equipped with 12 cell acid-delinted hill-drop cotton discs will plant from 3 to 6 seeds per cell. Select proper disc for seed size range to be planted.

To determine planter transmission setting, determine desired hill spacing and select the transmission ratio closest to the hill spacing in inches on the chart. To decrease population increase spacing. To increase population decrease spacing.

To determine population per acre, determine average seeds per hill and hills per acre by doing a field check. Measure $\frac{1}{1000}$ of an acre ($\frac{1}{1000}$ acre = Length of row 17' 5" for 30" row widths, 13' 10" for 38" row widths and 13' 1" for 40" row widths). Multiply average seeds per hill by hills per acre. EXAMPLE: 4 seeds per hill x (13 hills x 1000) = 52,000

Transmission Sprockets Drive Driven		NUMBER OF HILLS PER ACRE 12 Cell Hill-Drop Cotton, Acid-Delinted				Average Hill Spacing In Inches	Speed Range (MPH)
		30" Rows	36" Rows	38" Rows	40" Rows		
17	28	16,186	13,488	12,778	12,139	12.9	2 to 8
17	27	16,785	13,988	13,251	12,588	12.5	2 to 8
17	26	17,431	14,526	13,761	13,073	12.0	2 to 8
19	28	18,090	15,075	14,281	13,568	11.6	2 to 8
19	27	18,760	15,633	14,810	14,070	11.1	2 to 8
17	24	18,883	15,736	14,908	14,163	11.1	2 to 8
17	23	19,704	16,420	15,556	14,778	10.6	2 to 8
19	25	20,261	16,884	15,995	15,196	10.3	2 to 8
19	24	21,105	17,587	16,662	15,829	9.9	2 to 8
23	28	21,898	18,249	17,288	16,424	9.5	2 to 8
19	23	22,022	18,352	17,386	16,517	9.5	2 to 8
24	28	22,850	19,042	18,040	17,138	9.2	2 to 8
24	27	23,697	19,747	18,708	17,773	8.8	2 to 8
17	19	23,853	19,877	18,831	17,890	8.8	2 to 8
24	26	24,608	20,507	19,427	18,456	8.5	2 to 8
26	28	24,755	20,629	19,543	18,566	8.4	2 to 8
24	25	25,592	21,327	20,205	19,194	8.2	2 to 8
26	27	25,671	21,393	20,267	19,254	8.1	2 to 8
23	23	26,659	22,216	21,046	19,994	7.8	2 to 8
27	26	27,684	23,070	21,856	20,763	7.6	2 to 8
24	23	27,818	23,181	21,961	20,864	7.5	2 to 8
25	23	28,977	24,147	22,876	21,733	7.2	2 to 8
19	17	29,795	24,829	23,522	22,346	7.0	2 to 8
27	24	29,991	24,993	23,677	22,493	7.0	2 to 8
28	24	31,102	25,918	24,554	23,327	6.7	2 to 8
23	19	32,271	26,893	25,477	24,204	6.5	2 to 8
28	23	32,454	27,045	25,622	24,408	6.5	2 to 8
24	19	33,674	28,062	26,585	25,256	6.2	2 to 8
25	19	35,077	29,231	27,693	26,308	6.0	2 to 8
23	17	36,068	30,056	28,474	27,051	5.8	2 to 8
26	19	36,480	30,400	28,800	27,360	5.7	2 to 7
27	19	37,883	31,570	29,908	28,413	5.5	2 to 7
28	19	39,287	32,739	31,016	29,465	5.3	2 to 7
26	17	40,772	33,977	32,189	30,579	5.1	2 to 7
27	17	42,340	35,284	33,427	31,755	4.9	2 to 7
28	17	43,908	36,590	34,665	32,932	4.8	2 to 7

IMPORTANT: See "General Planting Rate Information" and "Checking Seed Population" pages for additional information.

NOTE: When using the Half Rate (2 to 1) Drive Reduction Package, rates will be approximately 50% of given numbers.

IMPORTANT: Always check seed population in the field to ensure planting rates are correct.

MACHINE OPERATION

DRY INSECTICIDE APPLICATION RATES APPROXIMATE POUNDS/ACRE AT 5 MPH FOR VARIOUS ROW WIDTHS

Meter Setting	30" Rows	36" Rows	38" Rows	40" Rows
CLAY GRANULES				
10	4.9	4.1	3.9	3.7
11	5.4	4.5	4.3	4.1
12	6.1	5.1	4.8	4.6
13	6.9	5.7	5.4	5.2
14	7.7	6.4	6.0	5.8
15	8.5	7.1	6.7	6.4
16	9.6	8.0	7.6	7.2
17	10.7	8.9	8.4	8.0
18	11.4	9.5	9.0	8.6
19	13.1	10.9	10.3	9.8
20	14.2	11.8	11.2	10.7
21	15.5	12.9	12.3	11.6
22	16.4	13.7	12.9	12.3
23	17.2	14.3	13.6	12.9
24	18.8	15.7	14.9	14.1
25	20.9	17.4	16.5	15.7
26	23.0	19.2	18.1	17.3
27	24.1	20.0	19.0	18.1
28	25.4	21.2	20.1	19.1
29	27.8	23.2	22.0	20.9
30	29.6	24.7	23.4	22.2
SAND GRANULES				
5	2.9	2.4	2.3	2.2
6	4.9	4.0	3.8	3.7
7	5.3	4.4	4.2	3.9
8	6.3	5.3	5.0	4.8
9	7.8	6.5	6.1	5.9
10	8.9	7.4	7.0	6.7
11	10.2	8.5	8.0	7.7
12	11.2	9.3	8.8	8.4
13	12.6	10.5	10.0	9.5
14	14.1	11.7	11.1	10.6
15	15.5	12.9	12.3	11.6
16	17.5	14.6	13.8	13.1
17	19.4	16.2	15.3	14.6
18	21.8	18.2	17.2	16.4
19	24.3	20.2	19.1	18.2
20	25.7	21.4	20.3	19.3
21	27.6	23.0	21.8	20.7
22	29.6	24.7	23.4	22.2
23	32.0	26.7	25.3	24.0
24	34.4	28.7	27.2	25.8
25	36.9	30.7	29.1	26.7

IMPORTANT: The above chart represents average values and should be used only as a starting point. The granular chemical flows through the given meter opening at a nearly uniform rate regardless of roller speed. Your actual rate will vary depending upon the insecticide you are using, your planting speed and your plant population. Planting speed/ground speed has the greatest effect on application rate.

Your actual rate must be checked in the field with the actual insecticide that you are using and at the speed and population at which you will be planting.

MACHINE OPERATION

DRY HERBICIDE APPLICATION RATES

APPROXIMATE POUNDS/ACRE AT 5 MPH FOR VARIOUS ROW WIDTHS

CLAY GRANULES

Meter Setting	30" Rows	36" Rows	38" Rows	40" Rows
10	4.7	3.9	3.7	3.5
11	5.2	4.4	4.1	3.9
12	5.8	4.9	4.6	4.4
13	6.5	5.4	5.1	4.9
14	7.3	6.1	5.7	5.5
15	8.2	6.9	6.5	6.2
16	9.0	7.5	7.1	6.8
17	9.9	8.2	7.8	7.4
18	10.7	8.9	8.4	8.0
19	11.6	9.7	9.2	8.7
20	12.6	10.5	10.0	9.5
21	13.6	11.3	10.7	10.2
22	14.6	12.1	11.5	11.0
23	15.7	13.1	12.4	11.8
24	17.0	14.1	13.4	12.8
25	18.1	15.1	14.3	13.6
26	19.4	16.2	15.3	14.6
27	20.9	17.4	16.5	15.7
28	22.6	18.8	17.8	17.0
29	24.3	20.2	19.1	18.2
30	26.7	22.2	21.1	20.0

IMPORTANT: The above chart represents average values and should be used only as a starting point. The granular chemical flows through the given meter opening at a nearly uniform rate regardless of roller speed. Your actual rate will vary depending upon the herbicide you are using, your planting speed and your plant population. Planting speed/ground speed has the greatest effect on application rate.

Your actual rate must be checked in the field with the actual herbicide that you are using and at the speed and population at which you will be planting.

ROW UNIT OPERATION

PLANTING DEPTH

Planting depth is maintained by the row unit gauge wheels. To increase or decrease the planting depth, first raise the planter to remove weight from the wheels. Then lift the depth adjustment handle and reposition it forward to decrease depth or rearward to increase planting depth. Adjust all units to the same setting initially. Then lower the planter and check operation and planting depth of all row units. It may be necessary to readjust some rows to obtain uniform operation.



WARNING: Never work under the planter while in raised position without using safety lockups.

72359-108

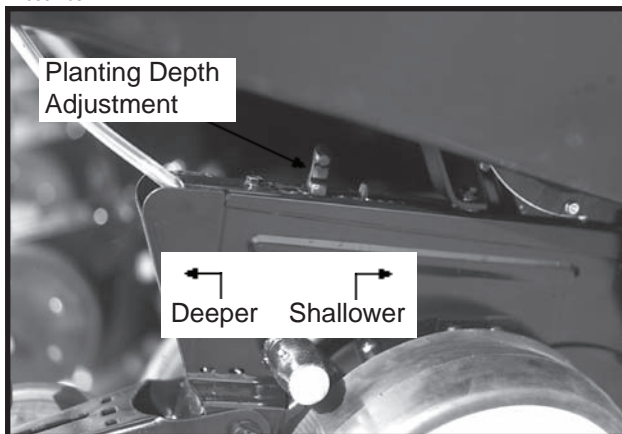

“V” CLOSING WHEEL ADJUSTMENT (Rubber And Cast Iron)



WARNING: Raise planter and install safety lockups before making closing wheel adjustments.

After adjusting planting depth, check the operation of the “V” closing wheels. The “V” closing wheels should have enough down pressure to close the seed trench and ensure good soil to seed contact. To increase spring pressure on the closing wheels, move the 5-position quick adjustable down force lever located on the top of the closing wheel arm to the rear. Moving the lever forward decreases spring tension.

Adjust all row units to a similar setting.

77121-10

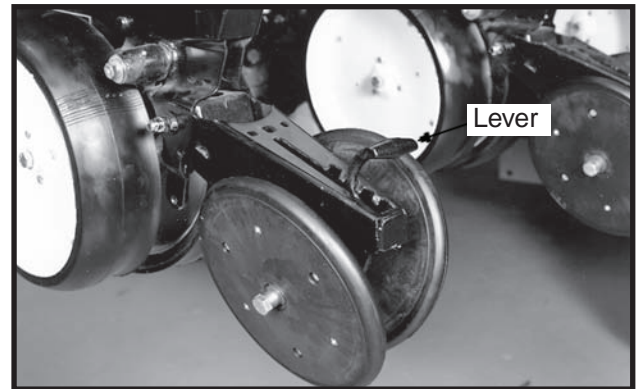

Light soil usually requires less down force at average depth (approximately 2") while heavy soil requires increased down force.

Eccentric bushings in the wheel arm stop allow for lateral adjustment of the “V” closing wheel assembly. Using a $\frac{3}{4}$ " wrench, loosen the hardware which attaches the closing wheel arm to the wheel arm stop. Using another $\frac{3}{4}$ " wrench turn the eccentric bushings until the **closing wheels are aligned with the seed trench**. Tighten hardware.

72359-129

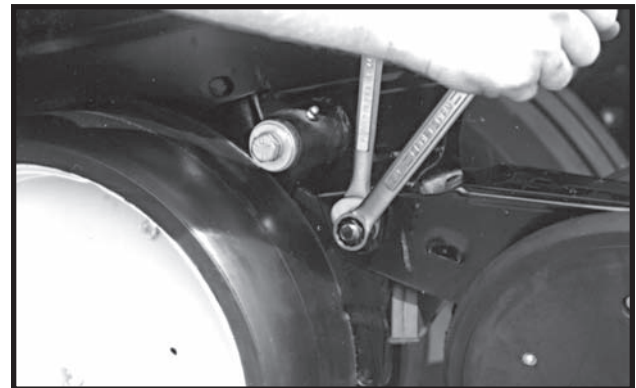

Bushings used for installation of the closing wheels can be moved from side to side for closing wheel spacing adjustment and the closing wheels can be installed in two locations either “offset” (to improve residue flow) or “directly” opposite. Under normal conditions the narrow position is preferred.

(PLTR95)

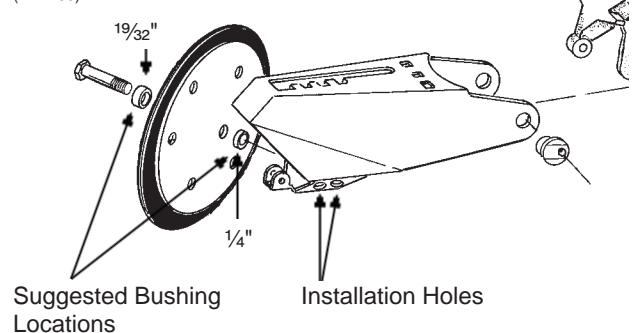

ROW UNIT OPERATION

COVERING DISCS/SINGLE PRESS WHEEL ADJUSTMENT



WARNING: Raise planter and install safety lockups before making covering discs/single press wheel adjustments.

72359-31



After adjusting planting depth, check the operation of the covering discs/single press wheels.

Initial press wheel down force setting should be with 2 1/2" between mounting arm tab and locking nut. To adjust down force spring, loosen 1/2" locking nut and turn adjusting bolt in to increase down force and out to decrease down force. Tighten locking nut against spring plug. Adjust all row units to a similar setting.

RH993(PLTR12)

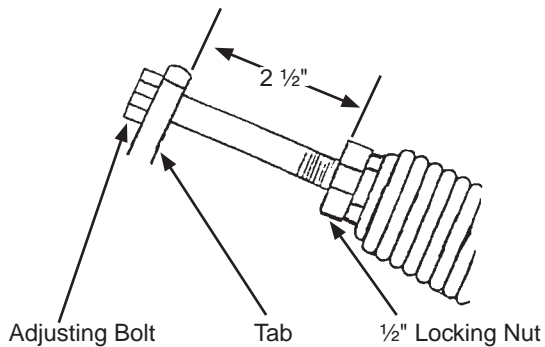

Eccentric bushings in the wheel arm stop allow for lateral adjustment of the covering discs/single press wheel assembly. Using a 3/4" wrench, loosen the hardware which attaches the assembly to the wheel arm stop. Using another 3/4" wrench, turn the eccentric bushings until the press wheel is aligned with the seed trench.

(PLTR96)

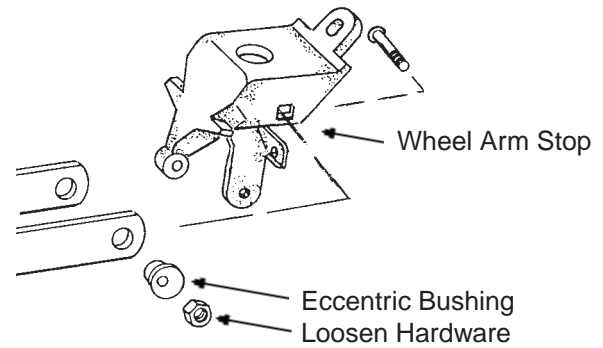

Two sets of holes in the mounting arm allow the covering discs to be located for staggered or side-by-side operation as desired.

72359-35

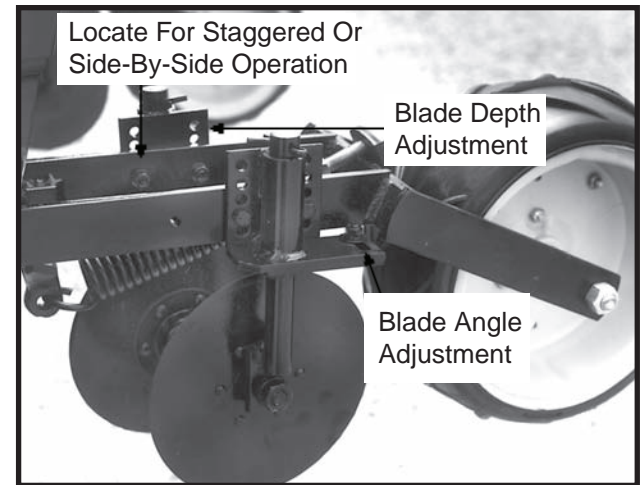

Five sets of holes in each disc bracket allow for 1/2" incremental blade depth adjustment.

Slotted holes in the disc mount and bracket allow for 0° - 15° blade angle adjustment.

Adjust covering discs on all row units to similar settings.

ROW UNIT OPERATION

FINGER PICKUP SEED METER

Refer to the planting rate chart for recommended seed drive transmission sprocket combinations.

60620-16

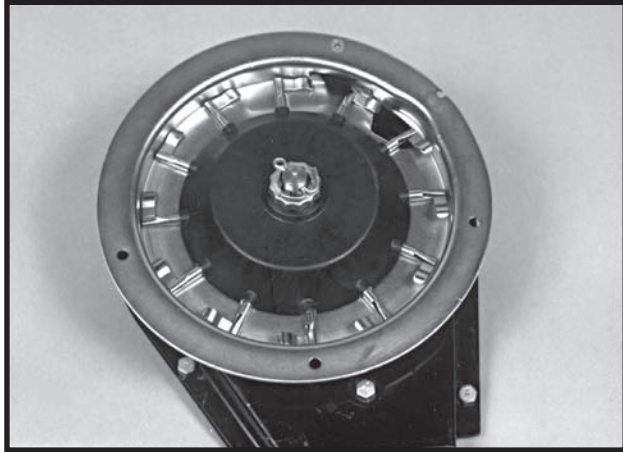

Shown With Corn Fingers Installed

The following seed fingers are available for use with the finger pickup seed meter:

(PLTR91/PLTR92)

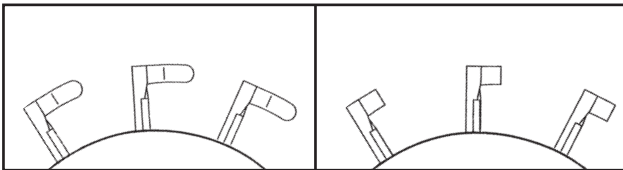

Corn Fingers

Oil Sunflower Fingers

No. 3 and/or No. 4 size oil sunflower seeds are recommended for use in the finger pickup seed meter equipped with oil sunflower fingers.

IMPORTANT: Always check seed population in the field to ensure planting rates are correct.

IMPORTANT: To ensure efficient operation of the finger pickup seed meter and extend the life of its components, mix one teaspoon of powdered graphite with the seed twice daily. Even distribution of the graphite with the seed is critical with newer seed coatings to provide lubrication for the seed pickup mechanism. Graphite application frequency may need to be increased if using additional seed additives.

82354-1



See "General Planting Rate Information", "Finger Pickup Seed Meter Troubleshooting" and "Finger Pickup Seed Meter Inspection/Adjustment" for additional information.

ROW UNIT OPERATION

BRUSH-TYPE SEED METER

60607-40(PLTR13)

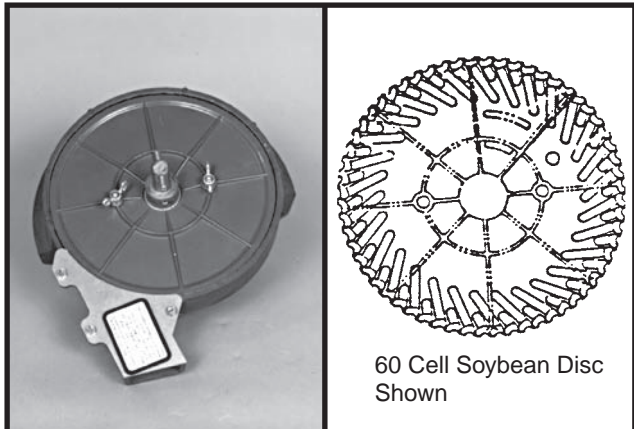

The following seed discs are available for use with the brush-type seed meter:

Soybean: 60 cells to meter seed sizes from 2200 to 4000 seeds per pound (Black color-coded).

(PLTR14)

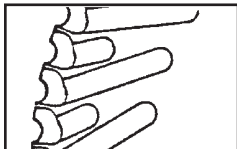

Specialty soybean: 48 cells to meter seed sizes from 1400 to 2200 seeds per pound (Dark blue color-coded).

(PLTR15)



Small milo/grain sorghum: 30 cells to meter seed sizes from 14,000 to 20,000 seeds per pound (Red color-coded).

(PLTR16)

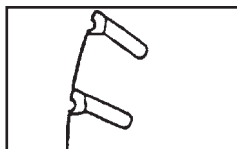

Large milo/grain sorghum: 30 cells to meter seed sizes from 10,000 to 16,000 seeds per pound (Light blue color-coded).

(PLTR17)

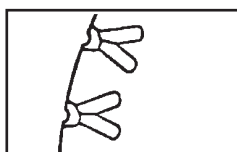

High rate small milo/grain sorghum:

60 cells to meter seed sizes from 12,000 to 18,000 seeds per pound (Red color-coded). (PLTR18)

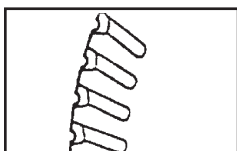

High rate large milo/grain sorghum:

60 cells to meter seed sizes from 10,000 to 14,000 seeds per pound (Yellow color-coded). (PLTR19)



Cotton, acid-delinted: 30 cells to meter seed sizes from 4200 to 5200 seeds per pound (White color-coded).

(PLTR20)

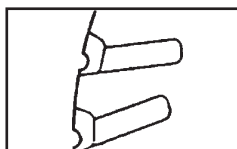

Large cotton, acid-delinted: 36 cells to meter seed sizes from 3800 to 4400 seeds per pound (Tan color-coded).

(PLTR21)

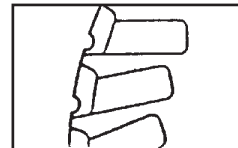

High rate cotton, acid-delinted: 48 cells to meter seed sizes from 4200 to 5200 seeds per pound (Light green color-coded).

(PLTR22)

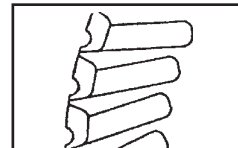

Hill-drop cotton, acid-delinted: 12 cells, 3 to 6 seeds/cell, to meter seed sizes from 4000 to 5200 seeds per pound (Brown color-coded). (PLTR23)

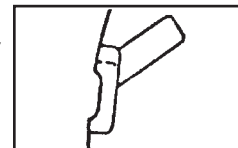

Small hill-drop cotton, acid-delinted: 12 cells, 3 to 6 seeds/cell, to meter seed sizes from 5000 to 6200 seeds per pound (Dark green color-coded).

(PLTR23)

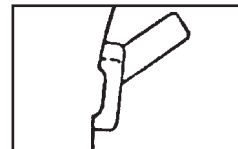

When installing the seed disc onto the meter hub, turn the disc counterclockwise while tightening the two wing nuts that retain the disc. The seed disc should have only slight resistance when rotated counterclockwise after wing nuts are tight.

The brush-type seed meter attaches to the seed hopper in the same manner as the finger pickup seed meter. Secure to bottom of seed hopper with two 5/16" flanged hex nuts. DO NOT OVER TIGHTEN.

Erratic seed spacing may result from misalignment between the drive coupler and seed meter input shaft. Misalignment may cause momentary stoppage of seed disc. Check alignment after initial installation. If adjustment is required, refer to "Meter Drive Adjustment" for correct procedure.

Refer to the planting rate charts in this manual for recommended seed drive transmission sprocket combinations.

IMPORTANT: Use powdered graphite or talc with each hopper fill of seed. Additional graphite or talc may be required to retard buildup of seed treatments on meter components. Frequency of monitor seed tube cleaning may be affected due to use of additional graphite or talc.

ROW UNIT OPERATION

82354-1



One tablespoon of **powdered graphite** per hopper fill of seed should be mixed in with the seed each time the hopper is filled. This prolongs the life of the brush-type seed meter components, reduces buildup of seed treatment on components in the meter and improves seed spacing.

Talc seed lubricant may be used in lieu of or in addition to graphite to reduce seed treatment buildup on seed disc and meter components and will improve meter performance. Coat seed disc and brushes with talc before installing meter. Fill hopper $\frac{1}{2}$ full of seed, add $\frac{1}{4}$ cup of talc and mix thoroughly. Finish filling hopper, add another $\frac{1}{4}$ cup of talc and mix thoroughly. Adjust rate of talc use as needed so all seeds are coated, while avoiding a buildup of talc in the bottom of the hopper. Humid conditions and/or small sized seeds with extra seed treatment may require as much as one cup of talc per hopper to prevent seed treatment buildup on seed disc and/or brushes.

CAUTION: Some liquid seed treatments or inoculants may create buildup on the seed disc or brushes. Check frequently for proper population and/or seed delivery when using any liquid seed treatment. All seed treatment should be thoroughly mixed with the seed per the manufacturers' recommendations. Seed treatment dumped on top of the seed after the hopper is filled, and not mixed properly will cause bridging of the seed in the meter, reducing population or stopping the meter from planting. Additional graphite or talc may be required to retard buildup of seed treatments on meter components.

IMPORTANT: Foreign material, such as hulls, stems, etc., may affect seed delivery. Clean seed is required to ensure accurate seed metering from the brush-type seed meter. Seed discs should be removed daily to check for buildup of foreign material, such as hulls, in the seed meter or the brushes.

SEED HOPPER

60620-69



The seed hopper has a capacity of 1.6 bushels.

When filling the seed hopper use clean seed and make certain there are no foreign objects in the hopper. **Replace hopper lids after hoppers are filled to prevent the accumulation of dust or dirt in the seed meter which will cause premature wear.** See "Finger Pickup Seed Meter Lubrication" and/or "Brush-Type Seed Meter Lubrication".

Periodically empty the hoppers completely to remove any foreign objects and to ensure proper seed meter operation. To empty hopper, disengage drive release and hopper latch and lift hopper off the hopper support. See "Meter Drive Release".

ROW UNIT OPERATION

SEED METER DRIVE ADJUSTMENT

IMPORTANT: The seed meter drive coupler must be properly aligned with the meter input shaft.

Improper alignment between the drive coupler and input shaft of the meter can cause the meter housing to flex as the meter rotates. This continual flexing of the meter housing can cause damage to the housing. Any time the hopper support panel is removed or replaced, vertical and horizontal alignment should be checked.

61658-27

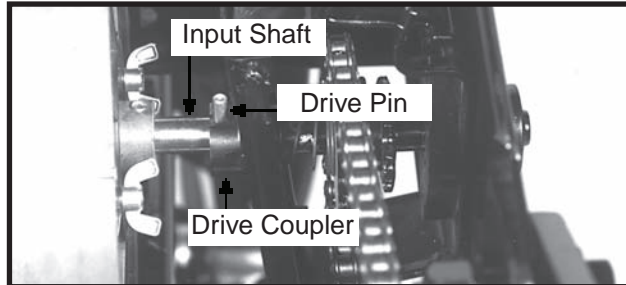

To check alignment:

- Inspect meter input shaft to make sure drive pin is centered.
- Install hopper with meter onto support panel and latch hopper.
- Rotate meter input shaft so drive pin is vertical.
- Rotate drive clutch so slots in coupler are vertical.
- Engage clutch.
- Clutch coupler should engage meter shaft freely with equal amount of pin extending beyond each side of drive coupler.
- Disengage clutch.
- Rotate both meter shaft and drive clutch to the horizontal position.
- Re-engage clutch.
- Clutch coupler should engage meter shaft freely with equal amount of pin extending beyond each side of drive coupler.

To adjust drive clutch:

- Slightly loosen both $\frac{5}{16}$ " cap screws.
- Move clutch assembly to correct any misalignment.
- Tighten both $\frac{5}{16}$ " cap screws.

72794-24

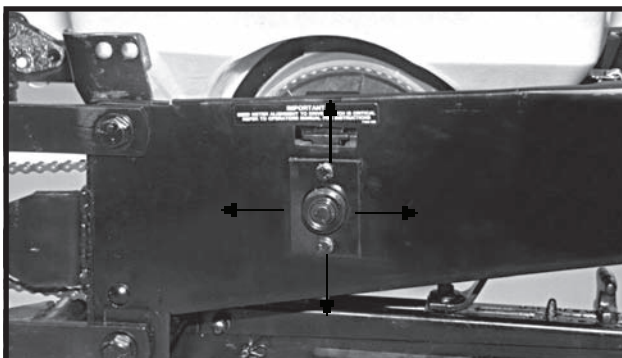

SEED METER DRIVE RELEASE

The seed meter drive is equipped with a clutch release mechanism that allows the drive to be disconnected from the seed metering unit for removal of seed hopper. Disconnecting the drive allows the operator to check granular chemical application rates without dropping seed. It also allows one or more of the rows to be disconnected when finishing fields.

72359-164

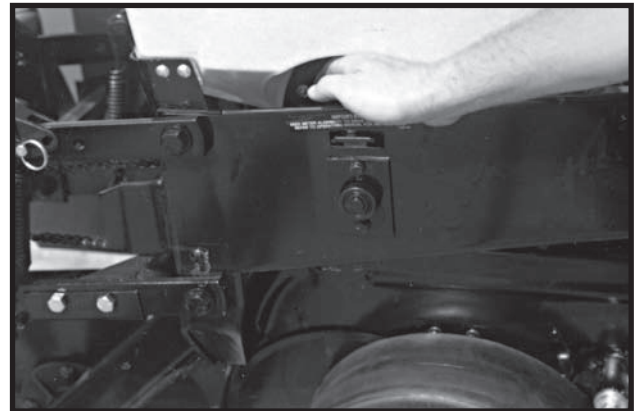

To disengage the drive, lift the release handle and pull outward until the handle locks in the slot in the side of the hopper side panel. To engage the row unit, lift and unlatch the handle. Spring tension will return the mechanism to the drive position.

Erratic seed spacing may result from misalignment between the drive coupler and seed meter input shaft. Misalignment may cause momentary stoppage of brush-type meter seed disc. Check alignment after initial installation. If adjustment is required, refer to "Meter Drive Adjustment" for correct procedure.

ROW UNIT OPERATION

ROW UNIT GAUGE WHEEL COVER

78896-6

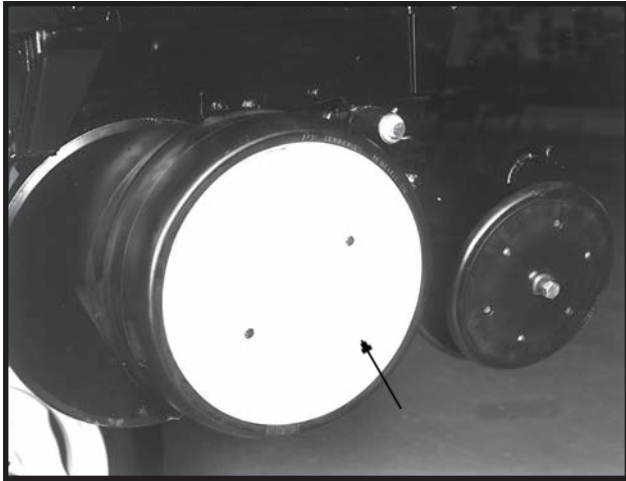

The row unit gauge wheel cover when installed on the gauge wheels next to the transport and/or drive wheels of the planter will aid in protecting the row units from rock damage.

DUAL GAUGE WHEEL

72359-53

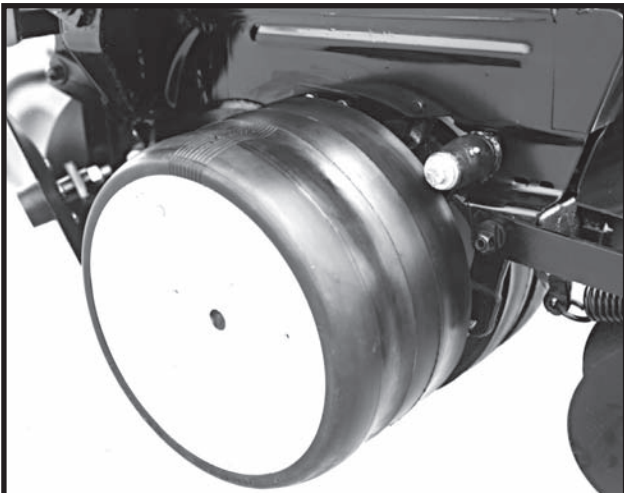

The dual gauge wheel is used to provide added width for additional row unit flotation in light sandy soil.

In some applications such as narrow row widths (less than 36") or where clearance is a problem, the added width of the dual gauge wheel may prevent its use.

ROW UNIT CHAIN ROUTING

For proper operation and to minimize wear, the row unit drive chains must be properly tensioned and aligned.

Inspect and replace weak, worn or broken springs and/or idlers and idler bushings.

NOTE: When idler shows signs of wear, it can be reversed for prolonged use.

72359-124(PLTR25)

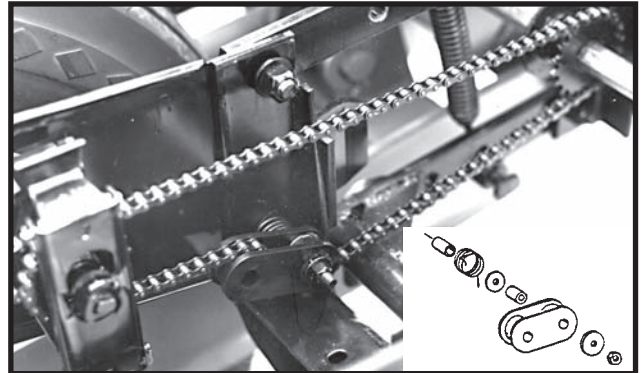

Pull Row Unit Meter Drive

72359-97(PLTR26)

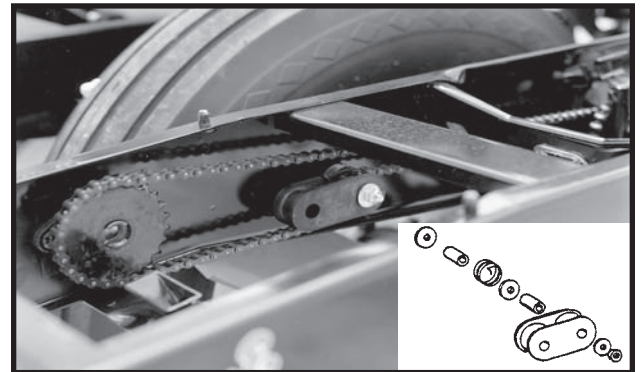

Row Unit Granular Chemical Drive

NOTE: Make sure connector link is installed with closed end located as shown below.

(PLTR24)

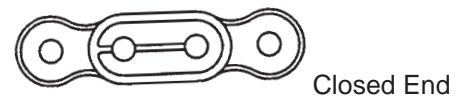

Direction Of Chain Travel →

ROW UNIT OPERATION

QUICK ADJUSTABLE DOWN FORCE SPRINGS

Quick adjustable down force springs are designed to increase penetration in hard soil and keep the row unit from bouncing in rough field conditions.

Two springs per row, one on the L.H. parallel arms and one on the R.H. parallel arms, are used unless equipped with row unit mounted no till coulters. Four springs per row are used with row unit mounted no till coulters.

61703-4

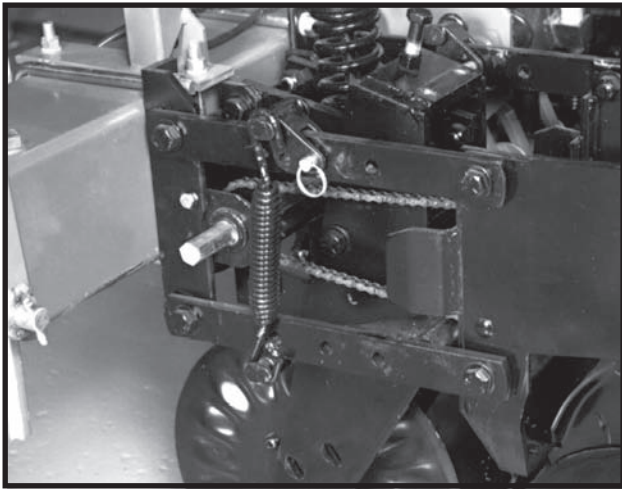

Two Springs Per Row (Dual)

72359-4

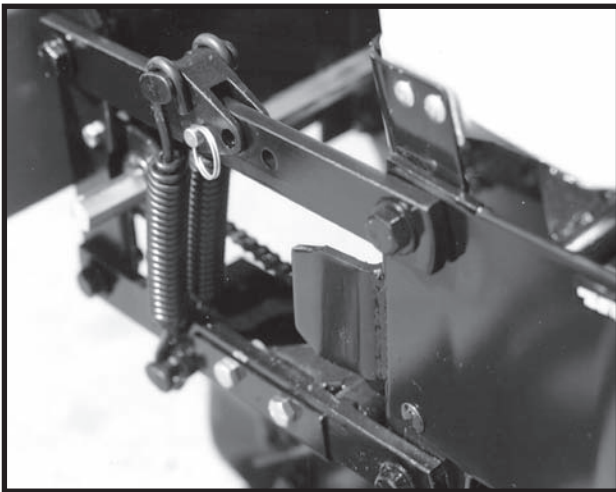

**Four Springs Per Row (Quad)
(Used Only In Conjunction With Row Unit Mounted No Till Coulters)**

There are four positions for spring tension adjustment. Position 1 allows for minimum down pressure and position 4 for maximum down pressure.

L0096(PLTR27d)

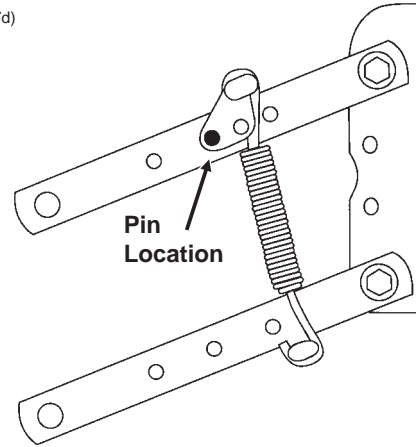

Position 1 (Minimum)

(PLTR28d)

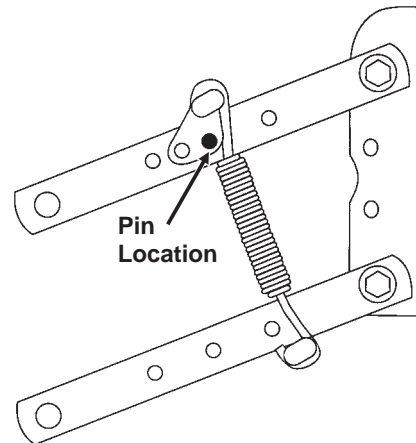

Position 2

(PLTR29d)

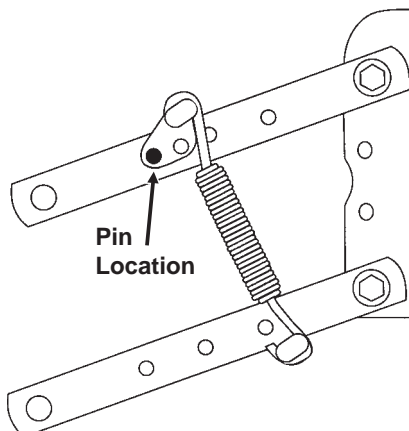

Position 3

ROW UNIT OPERATION

(PLTR30d)

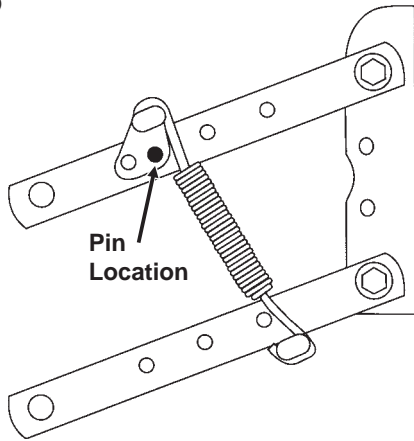

Position 4 (Maximum)

To adjust spring tension, raise planter and remove spring mount pin at top of spring. Slide mount to desired position and install pin.

NOTE: It is necessary for the operator to adjust springs according to field conditions. If springs are adjusted for too much down pressure for field conditions, it is possible for the row units to lift the planter to the extent that the drive wheels do not make sufficient contact. Too much down pressure in soft field conditions can cause the row unit to run too deep.



DANGER: Always install safety lockups or lower machine to the ground before working under or around the machine.

NOTE: Springs must always be installed with open side of spring hooks toward seed hopper to prevent binding on spring mount adjustment pin.

FRAME MOUNTED COULTER

Frame mounted coulters with 1" bubbled, 1" fluted (8 flutes) or $\frac{3}{4}$ " fluted (13 flutes) blades may be used on pull row units only.

The frame mounted coulter is designed to allow required spring down pressure on the coulter for maximum penetration while exerting less shock load on the row unit.

The frame mounted coulter can be used with or without the depth control bar installed. In most applications, especially in rocky planting conditions, the depth control bar **should not be used**. Use of the depth control bar transfers down force from the coulter to the row unit making less down force available to the coulter blade.

56314-14

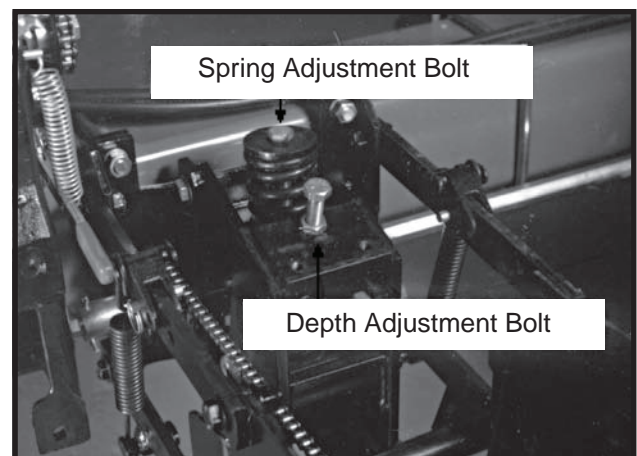

DEPTH ADJUSTMENT (Without Depth Control Bar Installed)

When the depth control bar is not used, operating depth of the coulter blade is determined by adjusting the depth adjustment bolt and positioning of the blade assembly in the fork mount. The depth adjustment bolt will stop downward travel of the coulter arm assembly. One turn of the adjusting bolt will change depth setting approximately $\frac{1}{4}$ ". Initial setting of the depth adjustment bolt should be with approximately $1 \frac{3}{8}$ " of thread showing. With this setting and the bar height at 20", the coulter depth will be approximately 2" with coulter mounting spindle in top hole. Turn the adjustment bolt clockwise to decrease operating depth. Turn the depth adjustment bolt counterclockwise to increase operating depth.

ROW UNIT OPERATION

56314-16

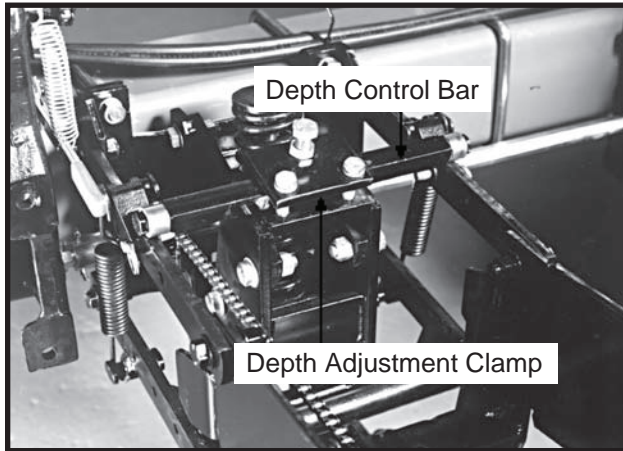

Depth Control Bar

Depth Adjustment Clamp

In certain applications it is desirable to use the depth control bar. In uneven terrain, use of the depth control bar allows greater depth control. The up and down movement of the row unit allows the coulters to move up and down at a rate of approximately 1/2 that of the row unit, maintaining a more uniform operating depth. When using the disc furrower attachment, the depth control bar should always be used, as operating depth of the coulters is critical for the disc furrowers to operate with minimal gouging.

DEPTH ADJUSTMENT (With Depth Control Bar Installed)

When using the depth control bar, down force springs must be located in the forward position and the depth adjustment bolt used only to attach the depth adjustment clamp to the coulters assembly. Operating depth of the coulters blade is adjusted by positioning the blade assembly in the fork mount. Four blade mounting adjustment positions are available at 1/2" increments. Initial position of the blade assembly should be in the top hole. This position will locate the coulters blade approximately 1/4" deeper than the row unit opener blade. In heavy residue it may be desirable to position the blade assembly in the second position to insure that the residue is cut and not forced down into the seed zone. Additional holes are used to compensate for coulters blade wear.

56314-1

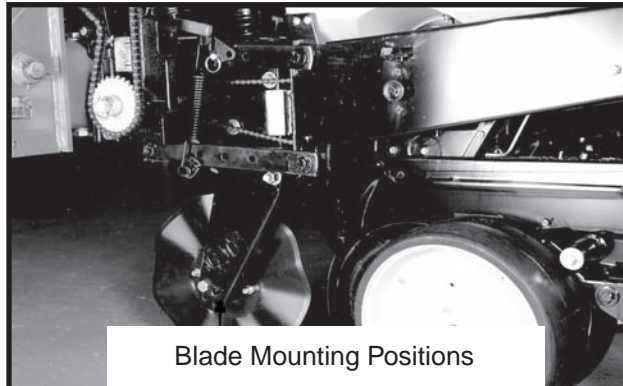

Blade Mounting Positions

Down force adjustment is made by tightening or loosening the spring adjustment bolt. With the planter in the raised position, turn the bolt clockwise to increase down force or counterclockwise to decrease down force. Set all rows equally.

Compressed Spring Length (Including Washer)	Pounds Down Pressure With Blade 1/2" Above Maximum Down Position	Pounds Down Pressure With Blade 4" Above Maximum Down Position
13 5/16"	90	230
12 5/16"	190	330
Suggested initial setting.		
11 5/16"	300	430

A5649rev.(PLTR44)

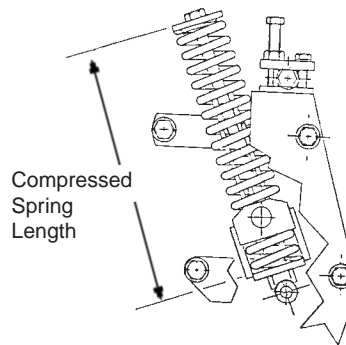

NOTE: Excessive down force may cause increased wear on components.

The coulters blade can be aligned with the row unit disc opener by moving the spacer washers from one side of the coulters blade hub to the other.

56314-12

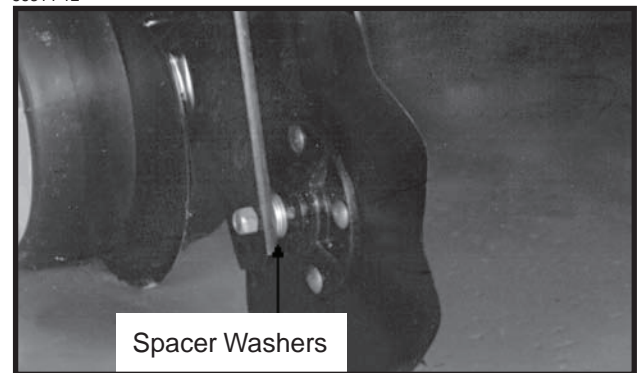

Spacer Washers

Field adjustment should be made as needed. Operating height of the planter frame will affect operating depth of the frame mounted coulters.

NOTE: Torque 5/8" spindle bolts to 120 ft. lbs.

ROW UNIT OPERATION

DISC FURROWERS (For Use With Frame Mounted Coulter)

Disc furrowers for use with the frame mounted coulter may be equipped with either 12" solid blades or 12" notched blades.

Disc furrowers are used to clear crop residue, dirt clods and dry soil from in front of the row units for a clean and smooth seed bed. Notched blades are used for heavier residue conditions. The notched blades cut crop residue and move it aside to prevent plugging or pushing.

56314-19

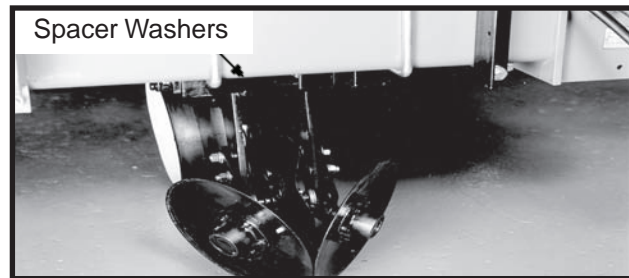

Blades can be adjusted so front edges meet by adding spacer washers between the disc furrower arm and frame mounted coulter fork mount.

Slotted holes in the frame mounted coulter fork mount and in the disc furrower arm allow for vertical and horizontal adjustment. Blades can be adjusted so the front edges meet or one blade can be moved to the rear and the other to the front of the slot so the cutting edge of one blade overlaps the edge of the other blade.

56314-17

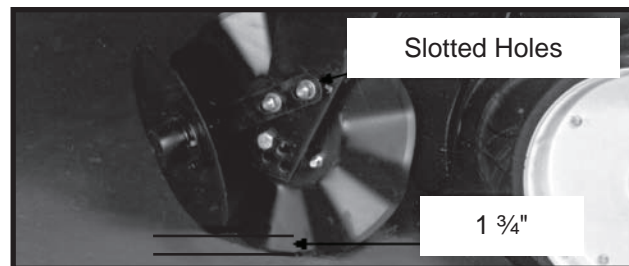

Initial setting for the disc furrowers is 1 3/4" shallower than the coulter blade. Further adjustment may be desired for various applications.

NOTE: The depth control bar should always be used when the frame mounted coulter is equipped with disc furrowers.

ROW UNIT MOUNTED DISC FURROWER

The row unit mounted disc furrower for use on pull row units only may be equipped with either 12" solid blades or 12" notched blades.

Disc furrowers are used to clear crop residue, dirt clods and dry soil from in front of the row units for a clean and smooth seed bed. Notched blades are used for heavier residue conditions. The notched blades cut crop residue and move it aside to prevent plugging or pushing.

59386-23

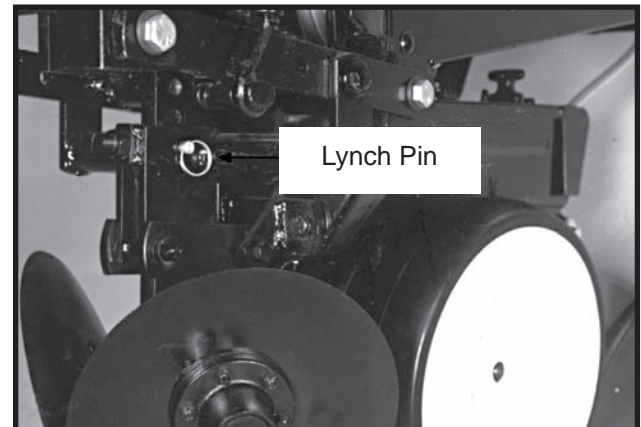

59386-20

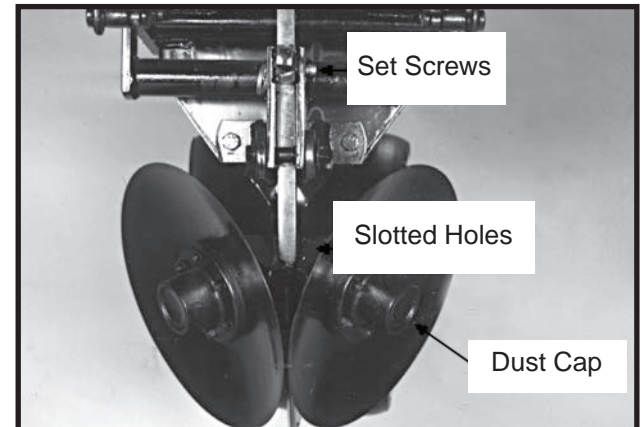

Vertical adjustment in 1/8" increments is possible by removing the lynch pin which secures the vertical support arm and moving the support arm up or down as required. Re-install lynch pin. Finer adjustment can be attained by removing the lynch pin and using the 5/8" x 2 1/4" set screw to clamp the support arm in the required position.

Slotted holes in the support arm where the blades are mounted allow fore and aft adjustment of the discs. Blades can be adjusted so the front edges meet or one blade can be moved to the rear and the other to the front of the slot so the cutting edge of one blade overlaps the edge of the other blade. The dust cap must be removed to make these adjustments.

ROW UNIT OPERATION

ROW UNIT MOUNTED BED LEVELER

59386-26

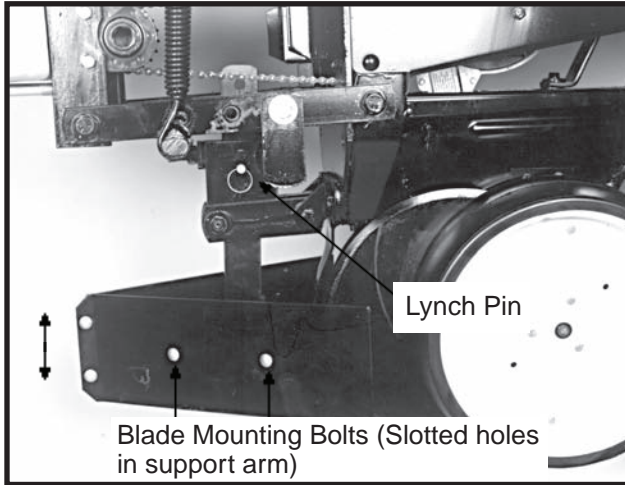

59386-30

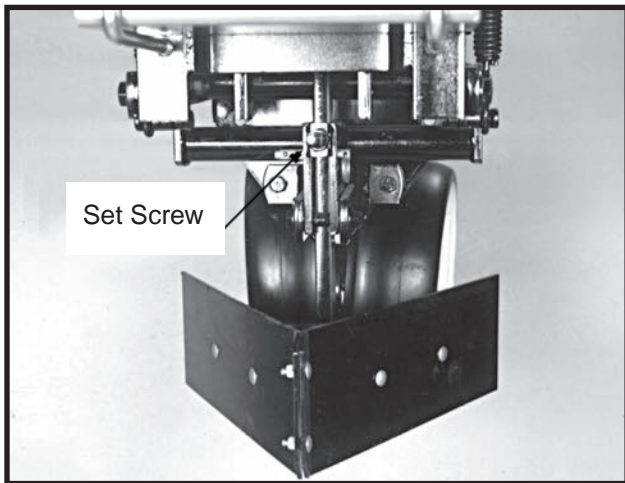

Row unit mounted bed levelers may be used on pull row units only.

Vertical adjustment in $\frac{1}{8}$ " increments is possible by removing the lynch pin which secures the vertical support arm and moving the support arm up or down as required. Re-install lynch pin. Finer adjustment can be attained by removing the lynch pin and using the $\frac{5}{8}$ " x 2 $\frac{1}{4}$ " set screw to clamp the support arm in the required position.

Slotted holes in the support arm where the blades are mounted allow tilting of the blades. The blades can be tilted up or down at the front for desired adjustment.

NOTE: The row unit mounted bed leveler is not compatible with row spacings less than 36".

ROW UNIT MOUNTED RESIDUE WHEEL

The row unit mounted residue wheel is designed for use on pull row units.

Two adjustable springs on the parallel links on each residue wheel allow for down force adjustment. Position 1 as shown below provides minimum down pressure and position 3 maximum down pressure.

Position 1 (Minimum) (PLTR31a)

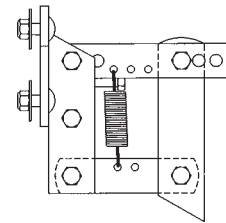

Position 2 (PLTR32a)

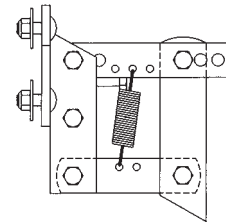

Position 3 (Maximum) (PLTR33a)

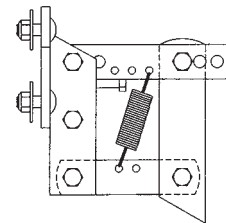

For additional uplift or float, position springs as shown below.

(PLTR34a)

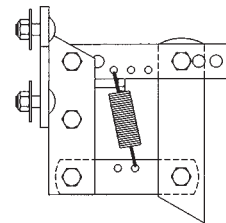

To adjust down force springs, raise the row unit out of the ground and reposition springs as shown for the desired down pressure.

ROW UNIT OPERATION

76782-31

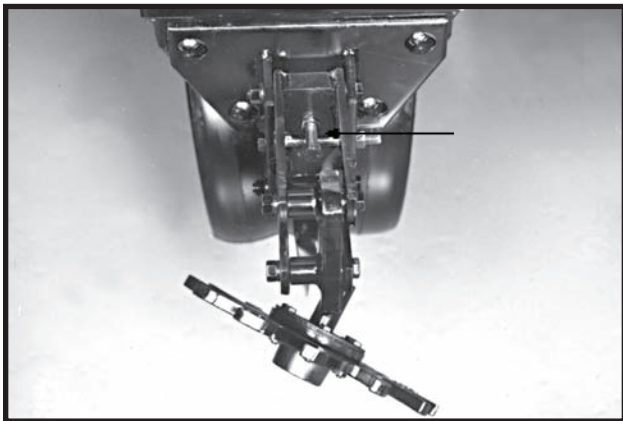

A full threaded bolt and jam nut located on the upper link allows maximum depth to be set for loose soil conditions. Initial setting should be 1 3/4" above the depth of the row unit double disc opener.

Three holes in the upper link allow for wheel angle adjustment. With the wheel mount in the most vertical position, using the rear hole in the upper link, the residue wheel is most aggressive. Moving the wheel mount to one of the forward holes reduces the aggressiveness of the wheel for use in mulch till applications where the soil is loose.

72794-29

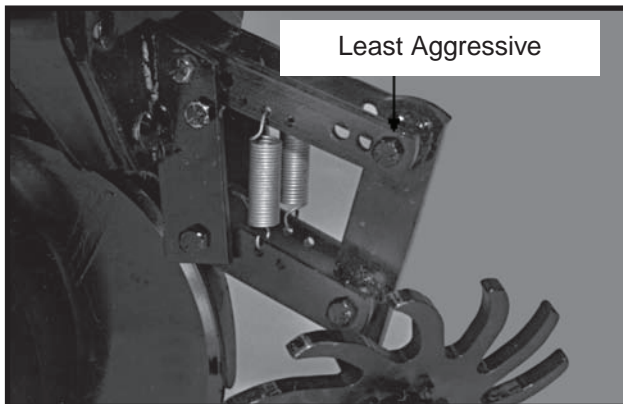

To lock the residue wheel up out of the ground, remove the 1/2" x 5" lockup bolt, raise the residue wheel and install bolt.

72794-31

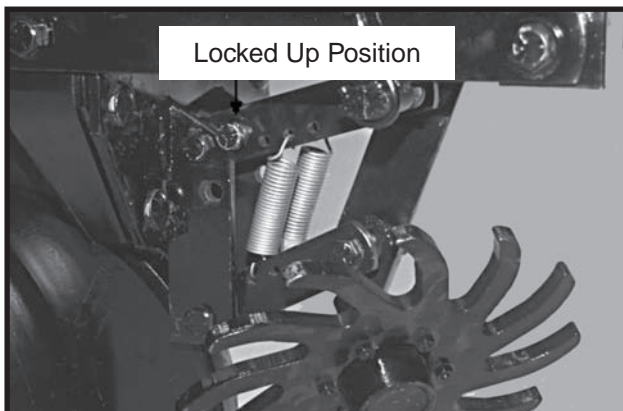

ROW UNIT MOUNTED NO TILL COULTER

80367-10



Row unit mounted no till coulters with 1" bubbled, 1" fluted (8 flutes) or 3/4" fluted (13 flutes) blades may be used on pull row units. (3/4" fluted shown)

Four quick adjustable down force springs are required per row when using row unit mounted no till coulters. See "Quick Adjustable Down Force Springs".

For proper operation the coulters blade should be aligned in relation to the row unit double disc openers. The coulters assembly can be adjusted by loosening the four attaching bolts, moving coulters arm to align and tightening the four attaching bolts.

The coulters can be adjusted to one of four 1/2" incremental settings in the forked arm. Initial location of the coulters is in the top hole. As the coulters blade wears, the blade should be adjusted downward to one of the three lower settings to maintain the coulters blade at or slightly below the opener discs. In very hard soil conditions such as compacted wheel tracks, opener penetration and cutting of surface residue may be improved by adjusting the coulters to operate below the depth of the double disc opener blades.

Operating depth can be checked by setting the planter down on a level concrete floor and checking the relationship between the coulters blade and row unit opener blade. Make sure the planter is level and coulters is square with the planter frame and aligned with the row unit disc opener.

NOTE: Torque 5/8" spindle bolts to 120 ft. lbs.

ROW UNIT OPERATION

COULTER MOUNTED RESIDUE WHEELS

80376-15

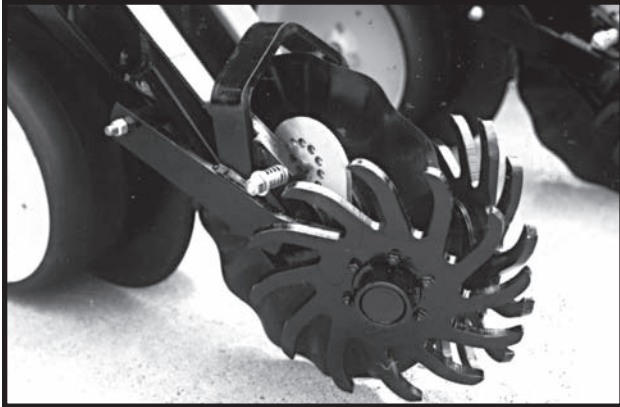

Coulter mounted residue wheels are designed for use on pull row unit.

The coulters mounted residue wheels are attached to the row unit mounted no till coulters with one cap screw and sleeve allowing the unit to free-float. A 2-position spindle bolt mounting allows the tined wheels to be mounted interlocked or staggered. Depth adjustment is made using a spring-loaded pin and cam with 11 positions in $\frac{1}{4}$ " increments. A high point on the cam allows the wheels to be locked up so they do not contact the ground.

SEED FIRING WHEEL

02209715

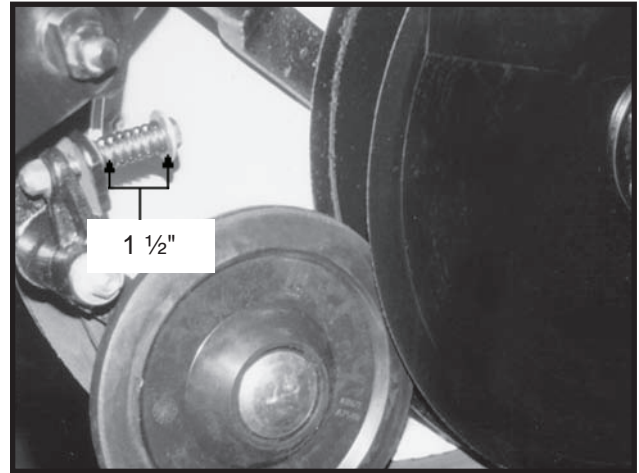

Shown with gauge wheel removed.

The seed firming wheel is designed for use on pull row units. Seed firming wheels are for use in dry loose soil conditions to gently and firmly press the seed into the seed bed before the closing wheels close the seed trench.

NOTE: Certain soil types and moisture conditions may lead to erratic performance resulting in irregular seed placement.

Initial spring tension is set leaving $1 \frac{1}{2}$ " between the washers.

ROW UNIT OPERATION

GRANULAR CHEMICAL HOPPER

61766-2

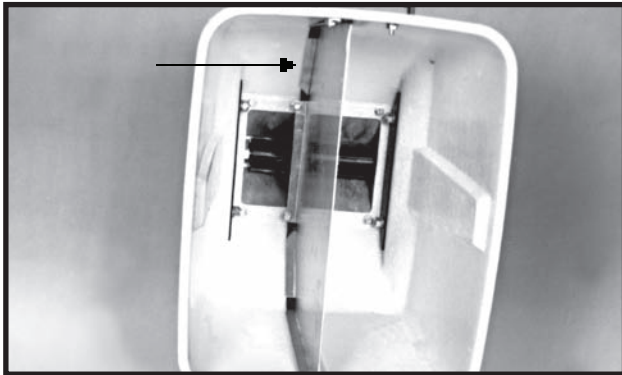

The granular chemical hopper has a 70 pound capacity. With the use of a hopper divider the hopper has two compartments with a 35 pound capacity in each.

Be sure no foreign objects get into the hopper when it is being filled. Replace the hopper lids after filling the hoppers to prevent the accumulation of dirt and moisture.

The metering gate located on the bottom of the hopper regulates the application rate. See “Dry Insecticide And Dry Herbicide Application Rate Charts” in this manual. Calibrate using the chemical manufacturers’ instructions.



DANGER: Agricultural chemicals can be dangerous. Improper selection or use can seriously injure persons, animals, plants, soil or other property. **BE SAFE:** Select the right chemical for the job. Handle it with care. Follow the instructions on the container label.

The granular chemical clutch drive coupler and meter shaft can be disengaged and engaged by turning the throwout knob located at the rear of the hopper support panel. To engage the drive, turn the knob ¼ turn clockwise. To disengage the drive, turn the knob ¼ turn counterclockwise. Slotted holes in the hopper support panel and clutch housing allow for alignment adjustment between the clutch drive coupler and meter shaft.

72359-183

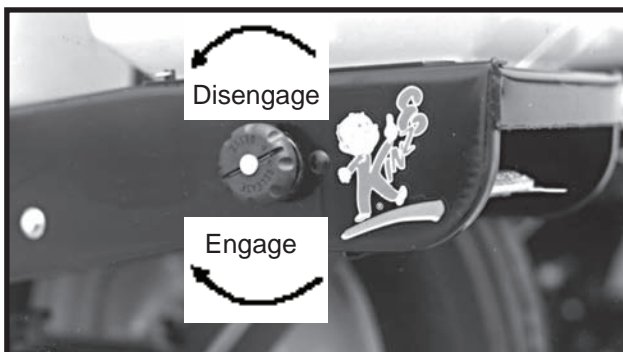

GRANULAR CHEMICAL RESTRICTOR PLATE

65249-17

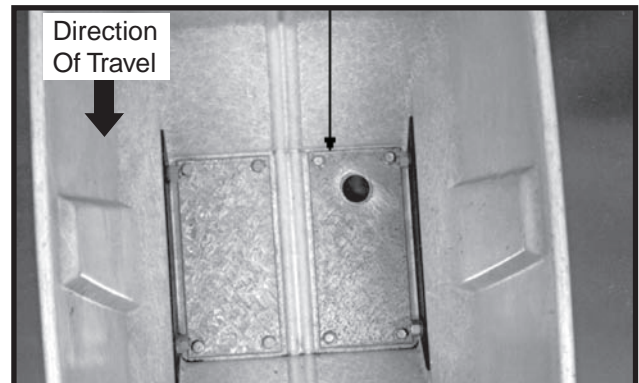

The granular chemical restrictor plate is designed for use in the granular chemical hopper when granular chemical application rates below 4 pounds per acre are desired. The plate restricts chemical flow to the meter outlet to prevent grinding of the material.

IMPORTANT: Check application rate of all rows in the field with the granular chemical you are using and at the speed and population at which you will be planting. See “Checking Granular Chemical Application Rate”.



DANGER: Agricultural chemicals can be dangerous. Improper selection or use can seriously injure persons, animals, plants, soil or other property. **BE SAFE:** Select the right chemical for the job. Handle it with care. Follow the instructions on the container label.

ROW UNIT OPERATION

GRANULAR CHEMICAL BANDING OPTIONS

Granular chemical banding options allow front and/or rear banding.

With use of the granular chemical hopper divider and second meter, two banding applications may be utilized.

NOTE: The granular chemical rear bander is not compatible with the covering discs/single press wheel option.

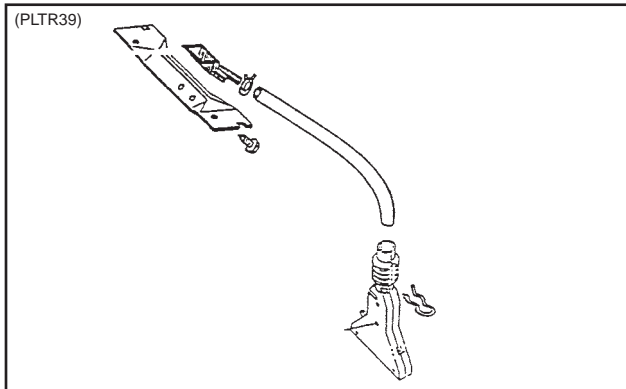

4 1/2" Slope-Compensating Bander

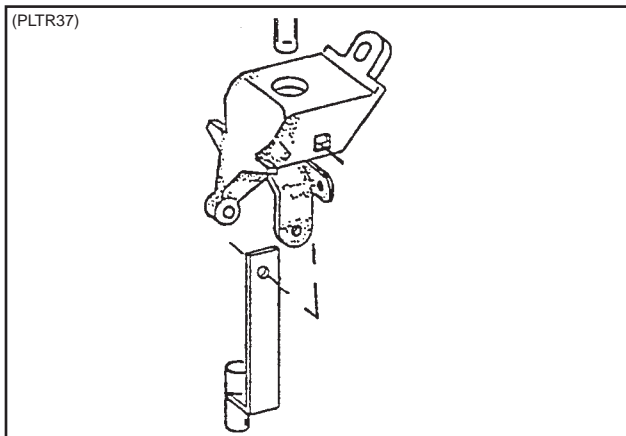

Straight Drop In-Furrow Placement

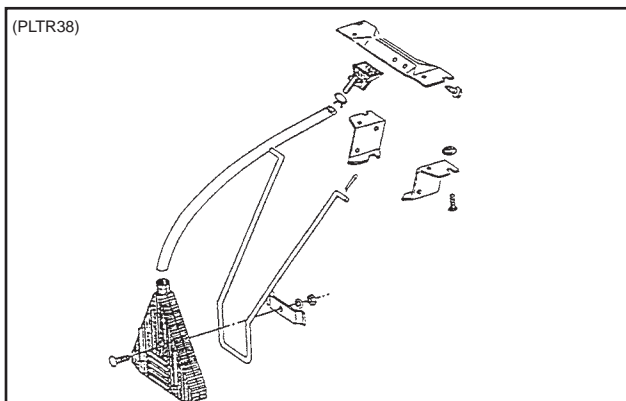

14" Rear Banding

SPRING TOOTH INCORPORATOR

The spring tooth incorporator smooths the soil behind the row unit and incorporates granular chemicals. The two mounting chains on each spring tooth incorporator should be adjusted so there is approximately 1/8" slack in the chain when the unit is lowered to planting position.

NOTE: The spring tooth incorporator is not compatible with the covering discs/single press wheel option.

73090-4a

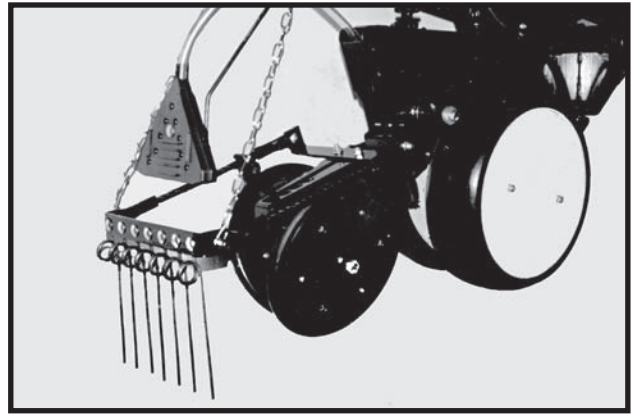

LUBRICATION

The following pages show the locations of all lubrication points. Proper lubrication of all moving parts will help ensure efficient operation of your KINZE® planter and prolong the life of friction producing parts.



DANGER: Always install safety lockups or lower to the ground before working under the machine.

LUBRICATION SYMBOLS



Lubricate at frequency indicated with an SAE multi-purpose type grease.



Lubricate at frequency indicated with a high quality SAE 10 weight oil or a quality spray lubricant.

SEALED BEARINGS

72794-21a

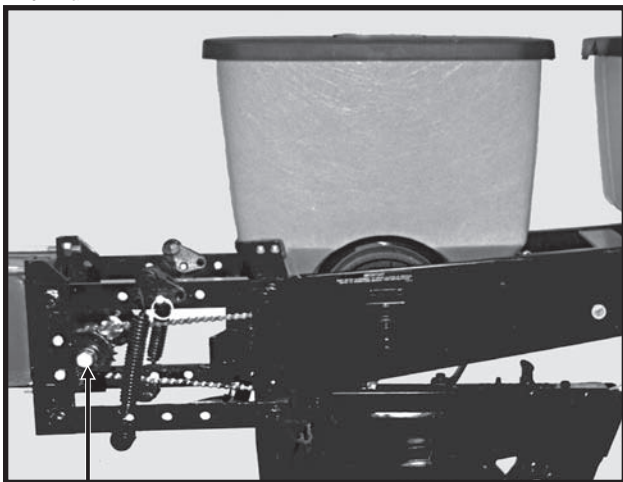

A number of sealed bearings are used on your KINZE® planter to provide trouble free operation. These are located in such areas as the drive shaft, row units and transmission bearings. Sealed bearings are lubricated for life, and due to the seals, relubrication is not practical.

WHEEL BEARINGS

Wheel bearings should be checked annually. Inspect for lubrication. Pump grease into the hub until grease comes out around the seals.

Lift wheel off the ground. Check for endplay in the bearings by moving the tire in and out. Rotate the tire to check for roughness in the bearings. If bearings sound rough, the hub should be removed and the bearings inspected and replaced if necessary. See "Wheel Bearing Packing Or Replacement".

POINT ROW WRAP SPRING CLUTCHES

81014-12

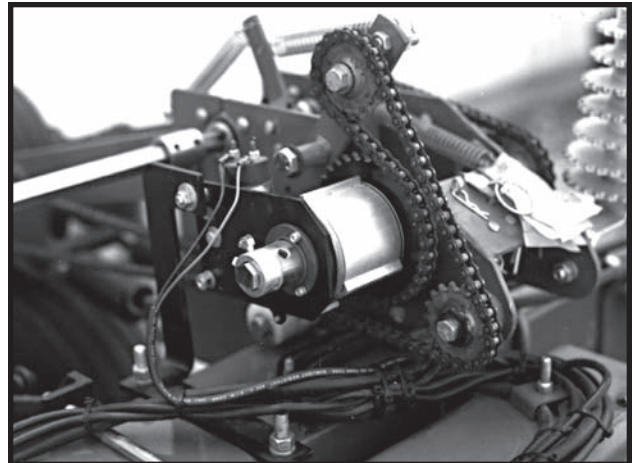

The point row wrap spring clutches are permanently lubricated and sealed and require no periodic maintenance. **DO NOT LUBRICATE. KEEP CLUTCHES CLEAN.**

LUBRICATION

DRIVE CHAINS

All transmission and drive chains should be lubricated daily with a high quality SAE 10 weight oil or a quality spray lubricant. Extreme operating conditions such as dirt, temperature or speed may require more frequent lubrication. If a chain becomes stiff, it should be removed, soaked and washed in solvent to loosen and remove dirt from the joints. Then soak the chain in oil so the lubricant can penetrate between the rollers and bushings.

81014-84

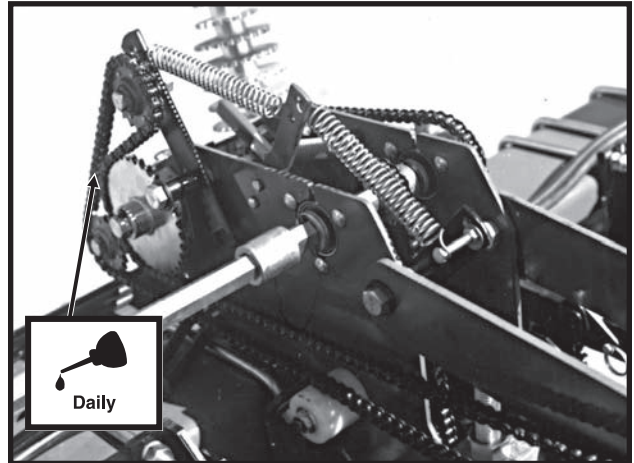

**Contact Wheel Drive Chain(s)
(Without Point Row Clutches)**

72359-123

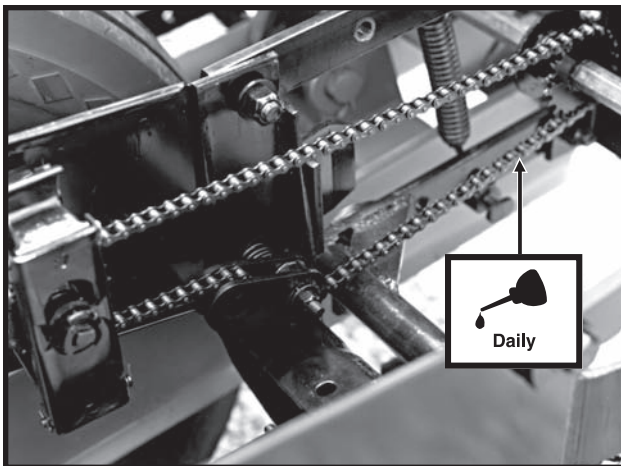

Pull Row Unit Seed Meter Drive Chain(s)

81014-12

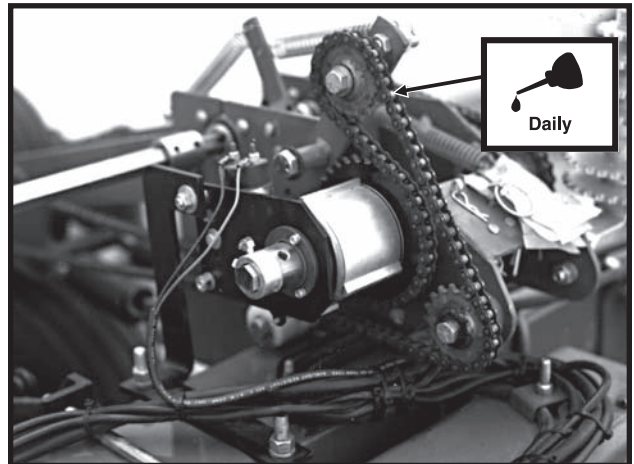

**Contact Wheel Drive Chain(s)
(With Point Row Clutches)**

72359-126

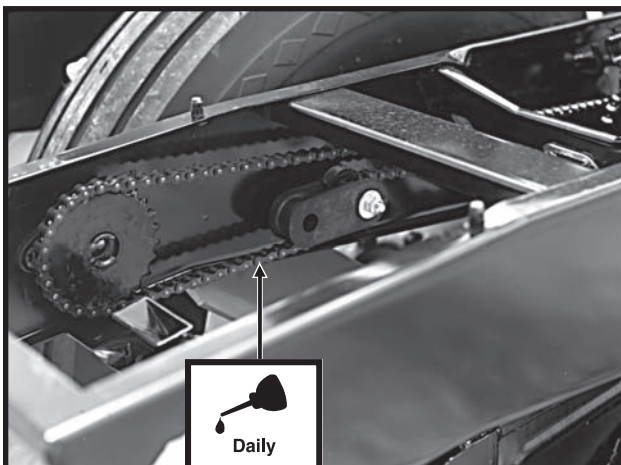

Row Unit Granular Chemical Meter Drive Chain(s)

81014-95/A7455(SFP26)

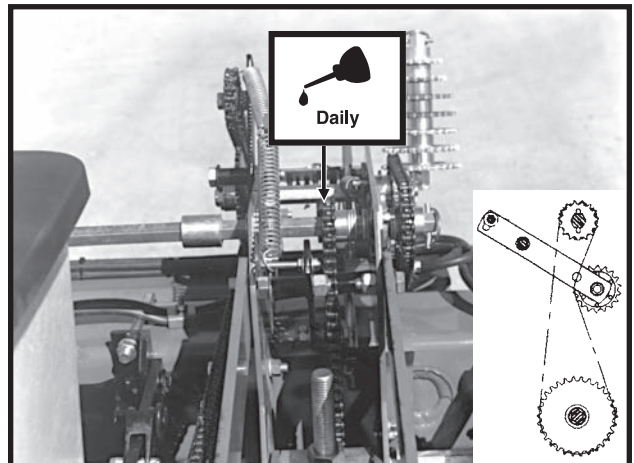

Inner Wheel Module Drive Chain(s)

LUBRICATION

81014-87

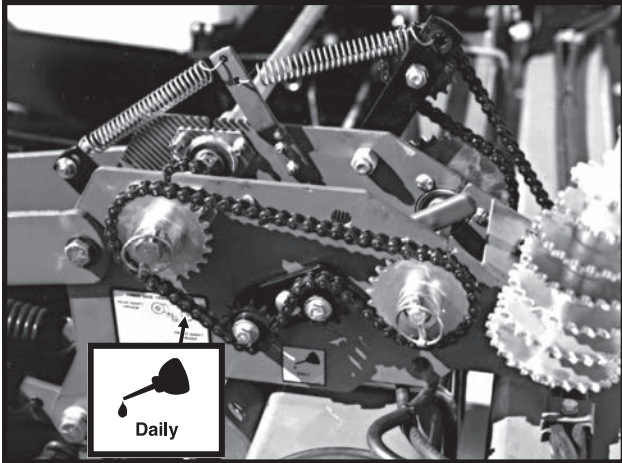

Seed Transmission Drive Chain(s)

07229624

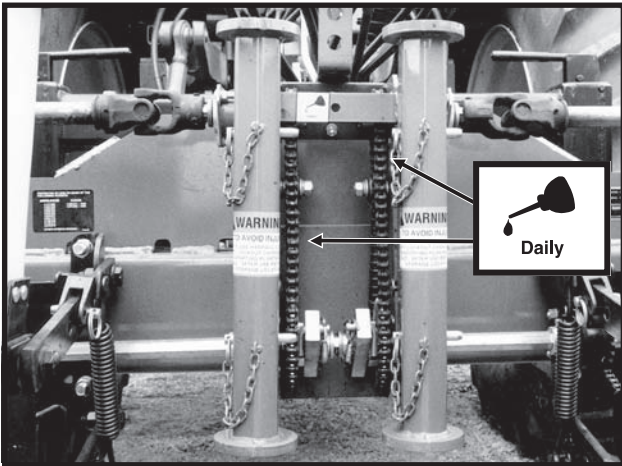

Center Drop Assembly Drive Chains

LUBRICATION

BUSHINGS

Lubricate bushings at the frequency indicated.

Using a torque wrench, check each bolt for proper torque. If bolt is loose, it should be removed and the bushing inspected for cracks and wear. Replace bushing if necessary. **Only hardened flat washers should be used. Replace damaged flat washers with proper part. Torque bolts to 130 ft. lbs.**

59386-18

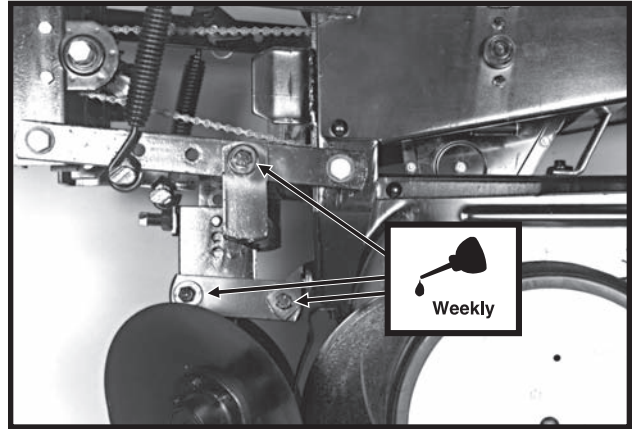

Row Unit Mounted Disc Furrower Parallel Linkage (6 Per Row)

59386-43

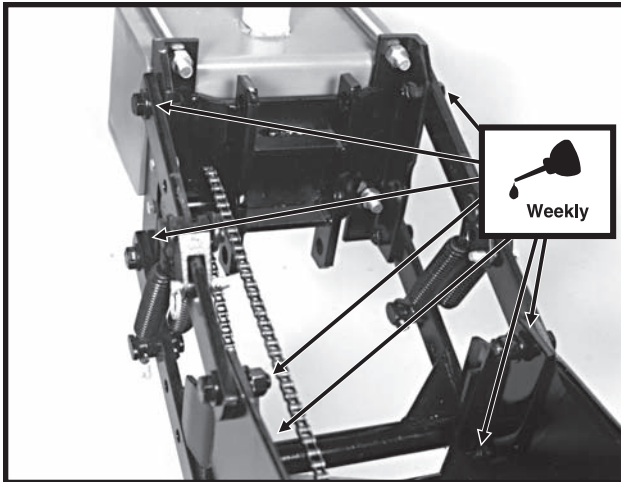

Row Unit Parallel Linkage (8 Per Row)

59386-26

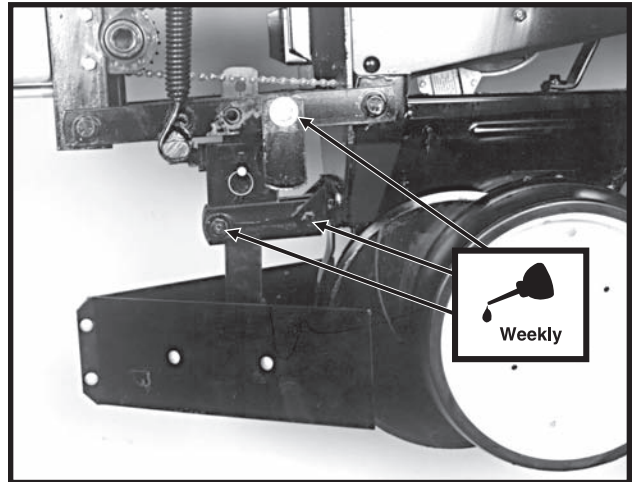

Row Unit Mounted Bed Leveler Parallel Linkage (6 Per Row)

56314-8

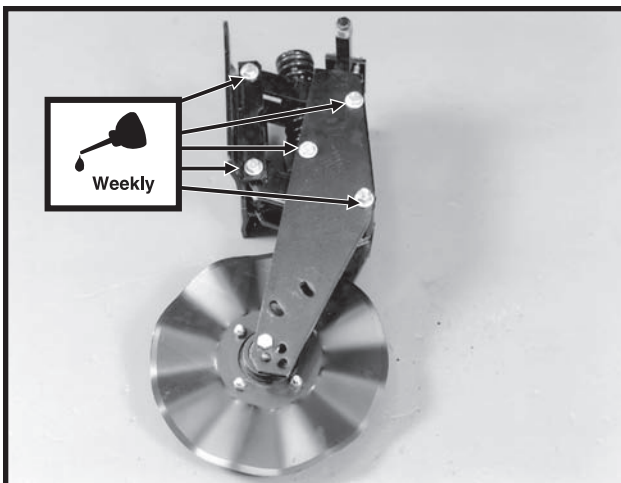

Frame Mounted Coulter Parallel Linkage (10 Per Row)

Shown not installed on row unit for visual clarity.

78896-18

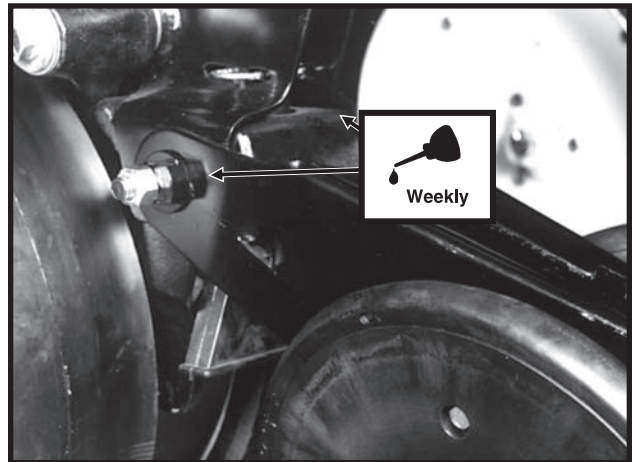

Row Unit Closing Wheel and/or Covering Discs/ Single Press Wheel Eccentric Bushings (2 Per Row)

LUBRICATION

81014-5

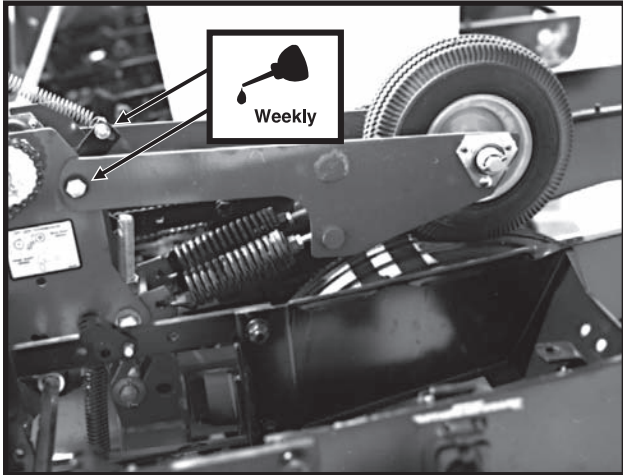

Contact Drive Wheel Arm (2 Per Wheel Assembly)

LUBRICATION

GREASE FITTINGS

Those parts equipped with grease fittings should be lubricated at the frequency indicated with an SAE multipurpose type grease. Be sure to clean the fitting thoroughly before using grease gun. The frequency of lubrication recommended is based on normal operating conditions. Severe or unusual conditions may require more frequent attention.



DANGER: Always install safety lockups or lower to the ground before working under or around the machine.

NOTE: Numbers on below photo correspond to photos on following pages showing lubrication frequencies.

81014-47

12 Row 30" Shown

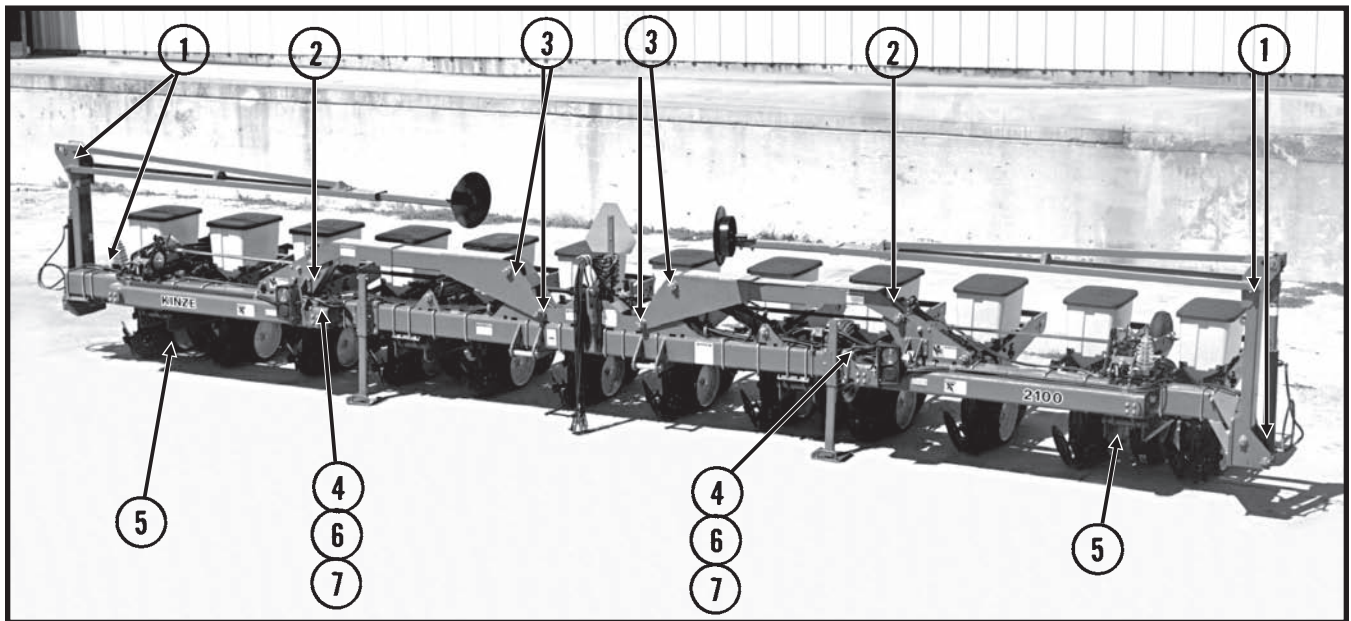

LUBRICATION

03279823

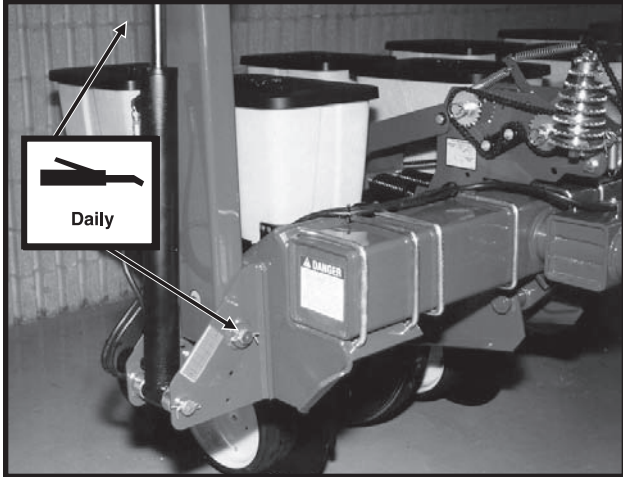

1. Markers - 4 Zerks Per Assembly On 8 Row 38"/40" And 12 Row 30" Sizes. 2 Zerks Per Assembly On 12 Row 36"/38", 38"/40" And 16 Row 30" Sizes.

81014-75

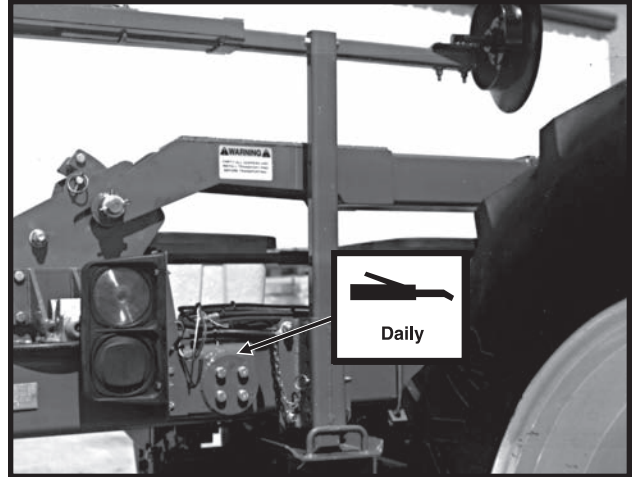

4. Link Assembly - 4 Zerks Per Link

81014-75

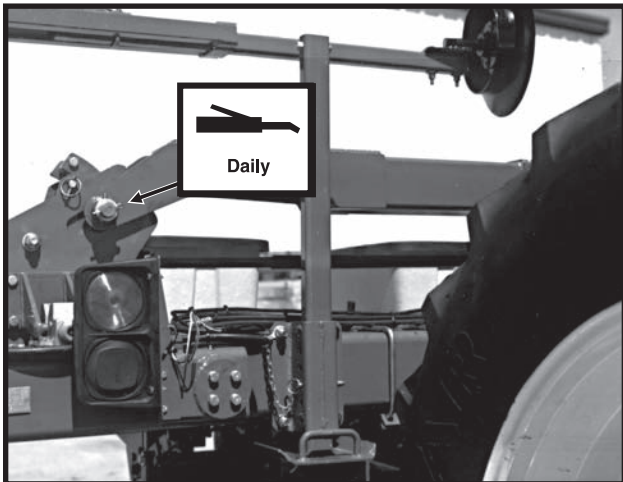

2. Wing Hinge - 2 Zerks Per Hinge Area

81014-79

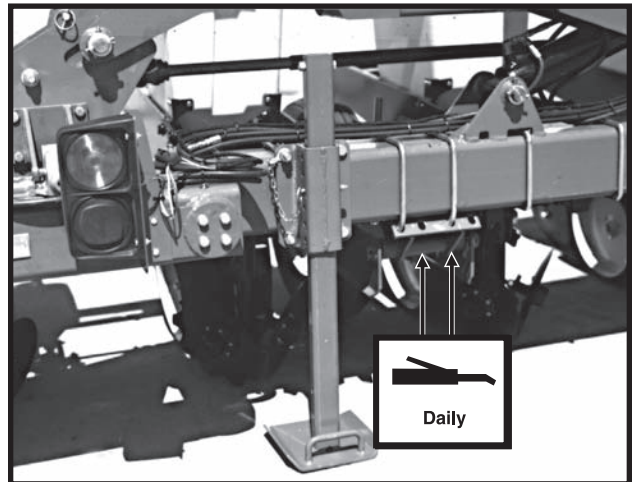

5. Drive Wheel Arm Clamp - 2 Zerks Per Clamp

81014-74

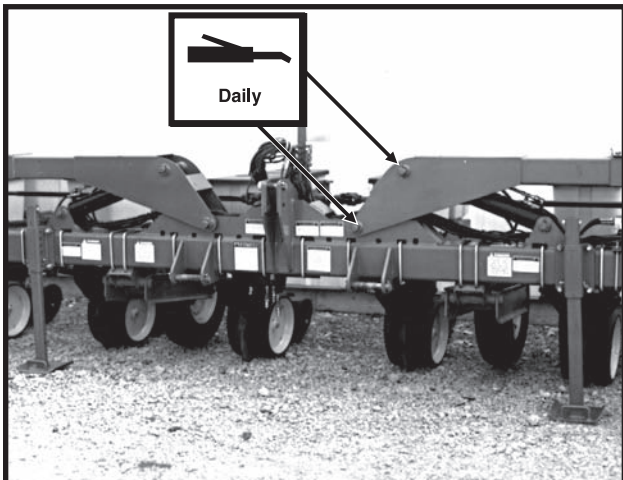

3. Center Hinge - 4 Zerks Per Hinge Area

81014-62

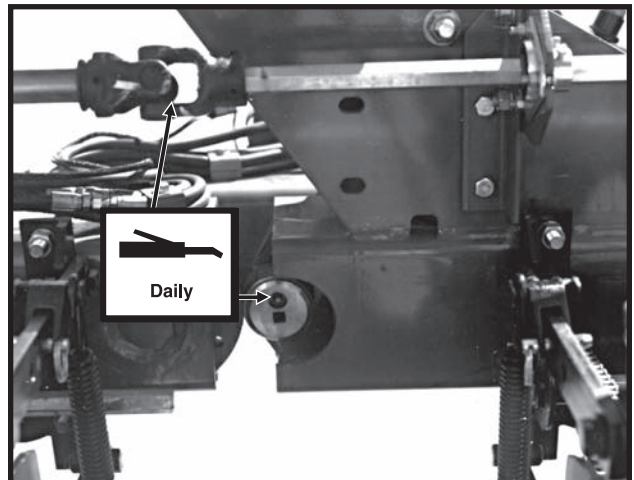

6. Cam Follower - 1 Zerk Per Cam
7. U-Joint Assembly - 1 Zerk Per Assembly

LUBRICATION

Row Unit

72359-106

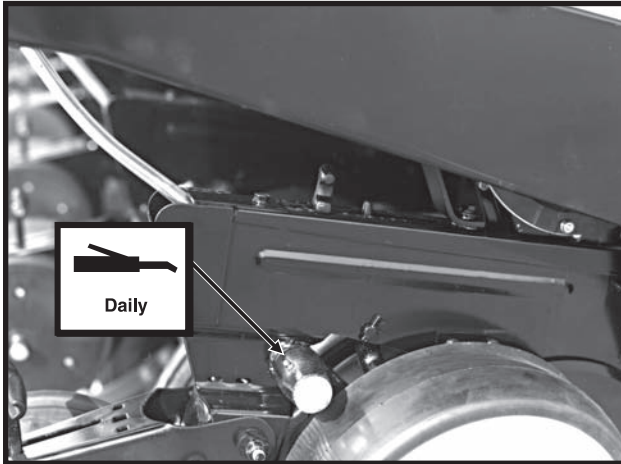

Gauge Wheel Arms - 1 Zerk Per Arm - 2 Per Row Unit

56673-6

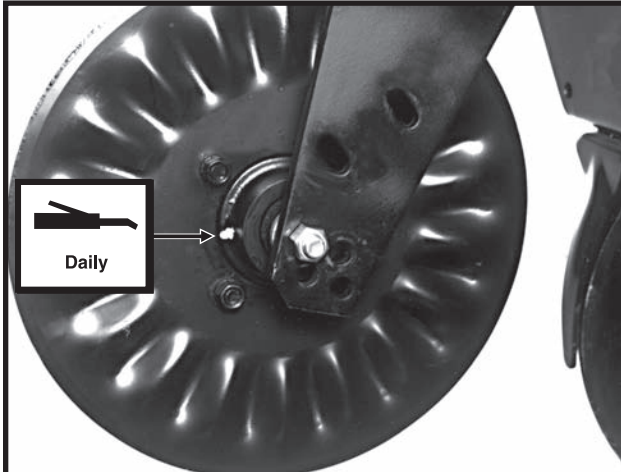

Frame Mounted Coultter Hubs - 1 Zerk Per Hub (Pump grease into hub until grease comes out around the seals. Spin hub while filling with grease.)

80367-10

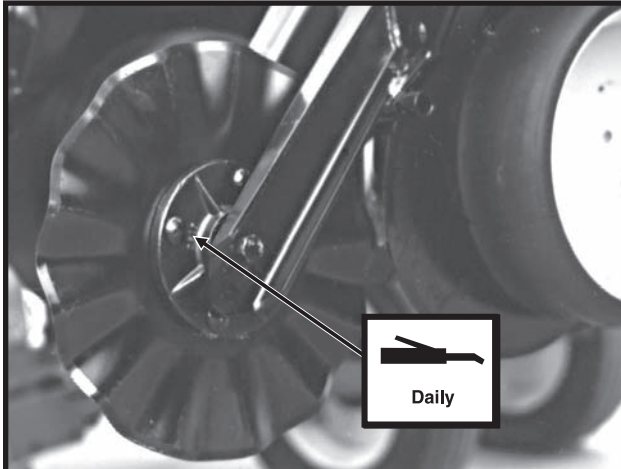

Row Unit Mounted No Till Coultter Hubs - 1 Zerk Per Hub (Pump grease into hub until grease comes out around the seals. Spin hub while filling with grease.)

Dual Lift Assist Wheel Package

A7443(SFP52a)

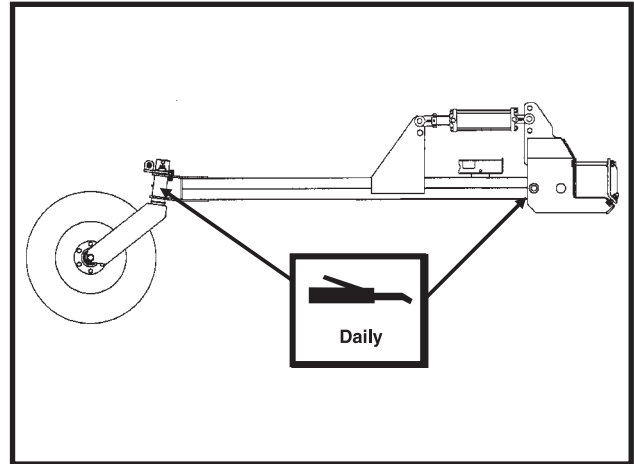

Lift Assist Arm - 2 Zerks Per Arm

MAINTENANCE

MOUNTING BOLTS AND HARDWARE

Before operating the planter for the first time, check to be sure all nuts and bolts are tight. Check all nuts and bolts again after approximately the first 50 hours of operation and at the beginning of each planting season thereafter.

All bolts used on the KINZE® planter are Grade 5 (high strength) unless otherwise noted. Refer to the torque values chart when tightening bolts.

Row unit parallel linkage bushing bolts - 130 Ft. Lbs. (See “Bushings” in the Lubrication Section of this manual.)

NOTE: Over tightening bolts can cause as much damage as under tightening. Tightening a bolt beyond the recommended range can reduce its shock load capacity.





WARNING: Before operating the planter for the first time and periodically thereafter, check to be sure the lug nuts on the transport wheels are tight. This is especially important if the planter is to be transported for a long distance.

Ground Drive Tire Lug Nuts - 90 Ft. Lbs.

5/8" No Till Coulter Spindle Bolts - 120 Ft. Lbs.

TORQUE VALUES CHART - PLATED HARDWARE						
Bolt Diameter	Grade 2		Grade 5		Grade 8	
	Coarse	Fine	Coarse	Fine	Coarse	Fine
1/4"	50 In. Lbs.	56 In. Lbs.	76 In. Lbs.	87 In. Lbs.	9 Ft. Lbs.	10 Ft. Lbs.
5/16"	8 Ft. Lbs.	9 Ft. Lbs.	13 Ft. Lbs.	14 Ft. Lbs.	18 Ft. Lbs.	20 Ft. Lbs.
3/8"	15 Ft. Lbs.	17 Ft. Lbs.	23 Ft. Lbs.	26 Ft. Lbs.	33 Ft. Lbs.	37 Ft. Lbs.
7/16"	25 Ft. Lbs.	27 Ft. Lbs.	37 Ft. Lbs.	41 Ft. Lbs.	52 Ft. Lbs.	58 Ft. Lbs.
1/2"	35 Ft. Lbs.	40 Ft. Lbs.	57 Ft. Lbs.	64 Ft. Lbs.	80 Ft. Lbs.	90 Ft. Lbs.
9/16"	50 Ft. Lbs.	60 Ft. Lbs.	80 Ft. Lbs.	90 Ft. Lbs.	115 Ft. Lbs.	130 Ft. Lbs.
5/8"	70 Ft. Lbs.	80 Ft. Lbs.	110 Ft. Lbs.	125 Ft. Lbs.	160 Ft. Lbs.	180 Ft. Lbs.
3/4"	130 Ft. Lbs.	145 Ft. Lbs.	200 Ft. Lbs.	220 Ft. Lbs.	280 Ft. Lbs.	315 Ft. Lbs.
7/8"	125 Ft. Lbs.	140 Ft. Lbs.	320 Ft. Lbs.	350 Ft. Lbs.	450 Ft. Lbs.	500 Ft. Lbs.
1"	190 Ft. Lbs.	205 Ft. Lbs.	480 Ft. Lbs.	530 Ft. Lbs.	675 Ft. Lbs.	750 Ft. Lbs.
1 1/8"	265 Ft. Lbs.	300 Ft. Lbs.	600 Ft. Lbs.	670 Ft. Lbs.	960 Ft. Lbs.	1075 Ft. Lbs.
1 1/4"	375 Ft. Lbs.	415 Ft. Lbs.	840 Ft. Lbs.	930 Ft. Lbs.	1360 Ft. Lbs.	1500 Ft. Lbs.
1 3/8"	490 Ft. Lbs.	560 Ft. Lbs.	1100 Ft. Lbs.	1250 Ft. Lbs.	1780 Ft. Lbs.	2030 Ft. Lbs.
1 1/2"	650 Ft. Lbs.	730 Ft. Lbs.	1450 Ft. Lbs.	1650 Ft. Lbs.	2307 Ft. Lbs.	2670 Ft. Lbs.

NOTE: Unplated hardware and bolts with lock nuts should be torqued approximately 1/3 higher than the above values. Bolts lubricated prior to installation should be torqued to 70% of value shown in chart.

	GRADE 2 No Marks		GRADE 5 3 Marks		GRADE 8 6 Marks
---	----------------------------	---	---------------------------	---	---------------------------

CHAIN TENSION ADJUSTMENT

The drive chains have a spring loaded idler and therefore are self-adjusting. The only adjustment needed is to shorten the chain if wear stretches the chain and reduces spring tension. The pivot point of these idlers should be checked periodically to ensure they rotate freely.

See “Drive Chains” in the Lubrication Section.

(MT18a)

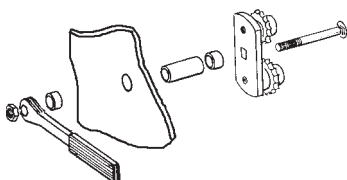

NOTE: The nut on the mounting bolt (on applicable idler assemblies) must be kept tight or chain tension will not be maintained and adjustment wrench will not function properly.

Additional chain links can be found in the storage area located in the wheel module.

81689-3

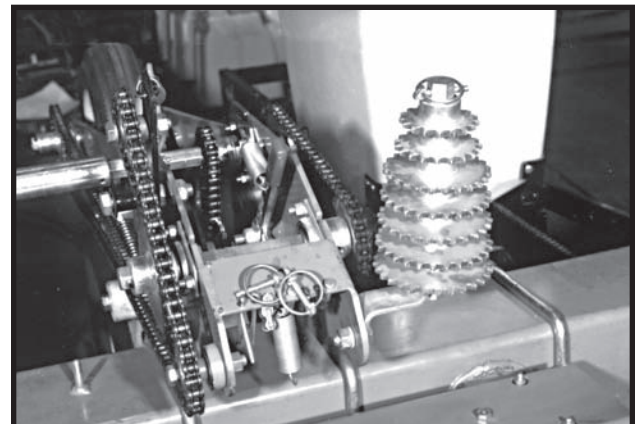

MAINTENANCE

FINGER PICKUP SEED METER INSPECTION/ADJUSTMENT

To inspect or service the finger pickup seed meter, remove the meter from the seed hopper by removing the two nuts which secure the mechanism to the hopper. Remove the baffle from the meter assembly by removing three cap screws. This will permit access to the finger pickup.

60620-8

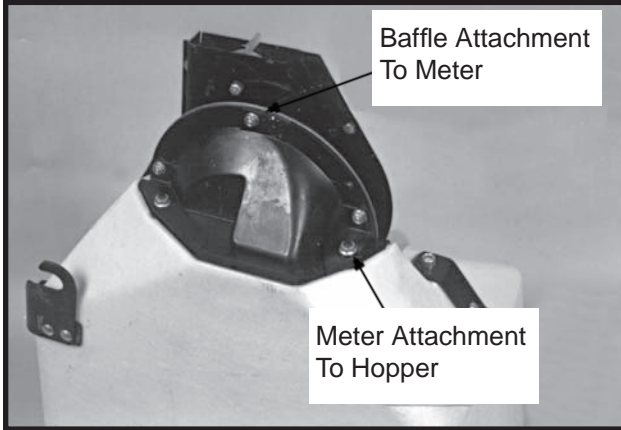

Rotate the seed meter drive by hand to ensure that the springs are holding the tabs of the fingers against the carrier plate where indicated in the photo and that the fingers are being raised in the correct area.

60620-16a

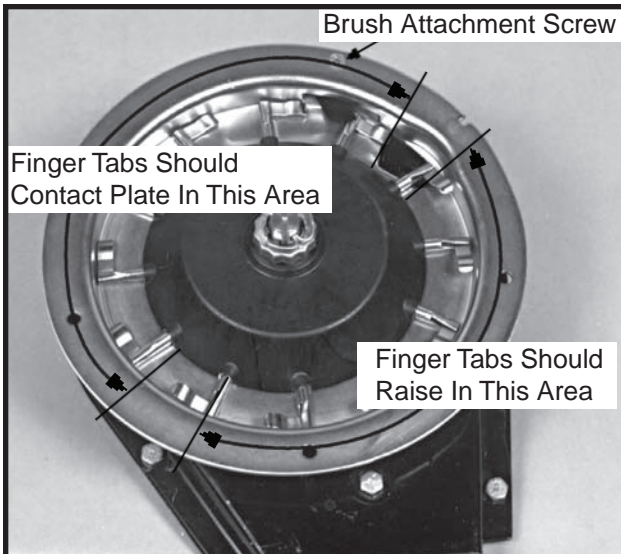

A build-up of debris or chaff may prevent proper finger operation and will require disassembly and cleaning of the corn meter as follows:

1. Remove cotter pin, cover nut, adjusting nut and wave washer (If Applicable) from drive shaft.
2. Carefully lift finger holder, along with fingers and cam, off of the shaft and clean.

60620-3a

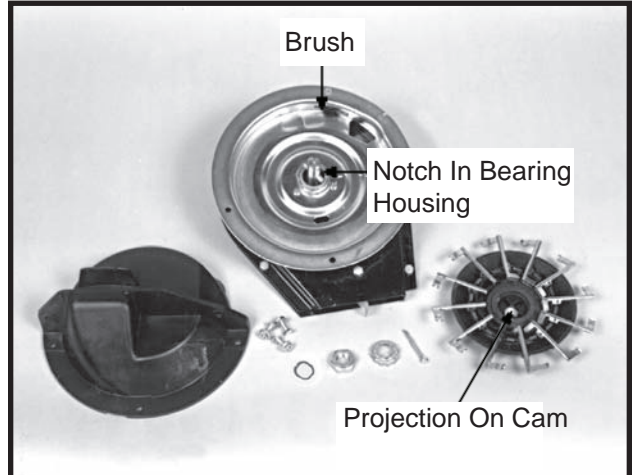

3. Check brush for wear and replace if necessary or following every 100 acres per row of operation.

EXAMPLE: Approximately 800 acres of corn on an 8 row machine or 1200 acres on a 12 row machine.

NOTE: It is not necessary to remove finger holder to remove brush.

4. To replace fingers or springs, remove springs from fingers and remove finger from holder by lifting it out of the friction fit slot. Under average conditions, life expectancy of these parts should be 600-900 acres per row of operation.
5. After cleaning and/or replacing defective parts, reassemble the meter in the reverse order. When replacing fingers, make sure the open end of the spring loop is toward the inside of the finger holder.

60620-22

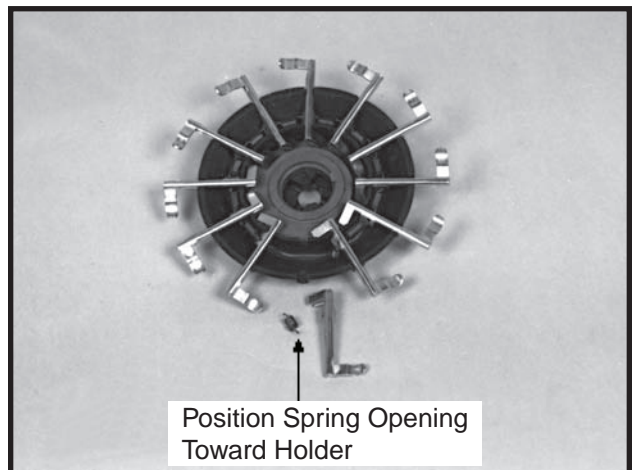

6. Make sure fingers are installed in holder so that holder will be positioned flush with the carrier plate when assembled. A projection on the cam is designed to align with a mating notch in the bearing housing to ensure proper operation when assembled.

MAINTENANCE

50725-4

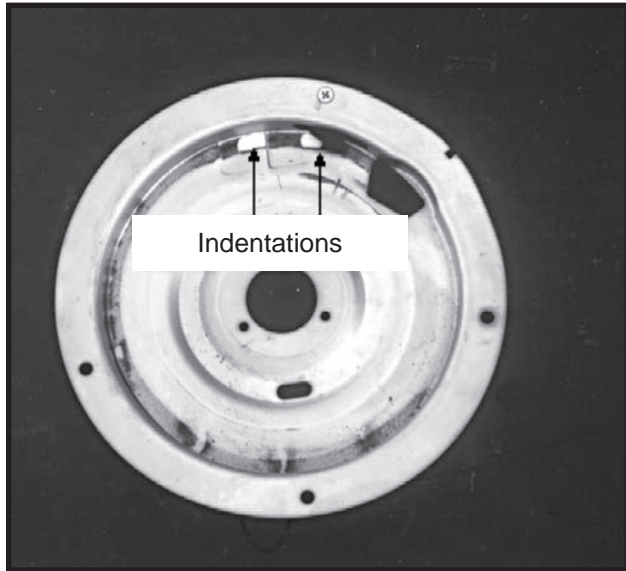

Photo shows worn plate

7. Before installing the finger holder on the carrier plate, check the indentations on the carrier plate for wear. Excessive wear of the carrier plate at the indentations will cause over planting especially when using small sizes of seed corn.

Inspect the carrier plate annually. Under average conditions, the life expectancy of the carrier plate should be 250-300 acres per row of operation.

8. With finger holder flush against the carrier, install wave washer and adjusting nut. Tighten adjusting nut to fully compress wave washer. Then back off nut $\frac{1}{2}$ to 2 flats ($\frac{1}{12}$ to $\frac{1}{3}$ turn) to obtain rolling torque of 14 to 22 inch pounds.
9. Turn finger holder by hand to make sure it is positioned firmly against the carrier, but is not over tightened and can be rotated with moderate force.
10. Install cage nut and cotter pin and reinstall housing.

NOTE: Check tightness of adjusting nut on each unit after first day of use and periodically thereafter.

To inspect or replace the seed belt, remove the four cap screws around the edge of the housing cover and the nut from the belt idler mounting bolt.

60620-13

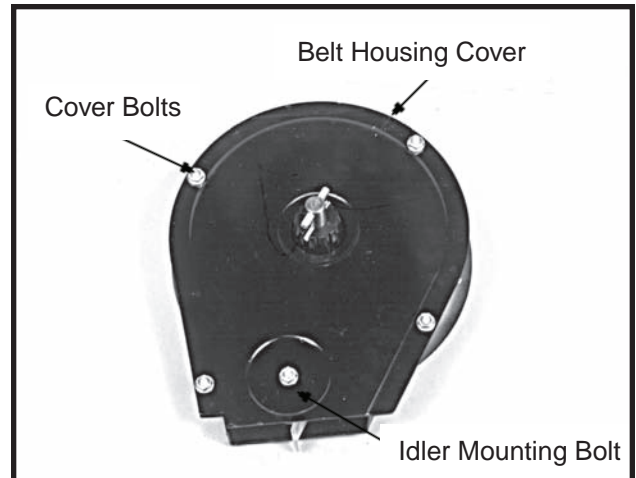

60887-97

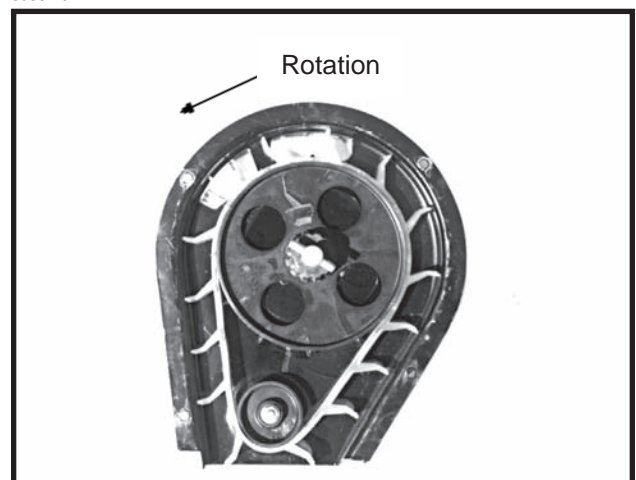

If the belt is being replaced, make sure it is installed to correctly orient the paddles as shown. A diagram molded into the drive sprocket also illustrates the correct orientation.

CAUTION: Do not over tighten hardware.

FINGER PICKUP SEED METER CLEANING

1. Disassemble meter.
2. Blow out any foreign material present in the meter mechanism.
3. Wash in mild soap and water. DO NOT USE GASOLINE, KEROSENE OR ANY OTHER PETROLEUM BASED PRODUCT.
4. Dry thoroughly.
5. Coat lightly with a rust inhibitor.
6. Reassemble and store in a dry place.

MAINTENANCE

FINGER PICKUP SEED METER TROUBLESHOOTING

PROBLEM	POSSIBLE CAUSE	SOLUTION
One row not planting seed.	Drive release not engaged.	Engage drive release mechanism.
	Foreign material in hopper.	Clean hopper and finger carrier mechanism.
	Seed hopper empty.	Fill seed hopper.
	Pin sheared in drive release sprocket.	Replace pin. Inspect meter for obstructions or defective parts.
	Row unit drive chain off of sprocket or broken.	Check drive chain.
Drive release does not engage properly.	Drive release shaft is not aligned properly with meter drive shaft.	Align drive mechanism. See "Seed Meter Drive Adjustment".
Unit is skipping.	Foreign material or obstruction in meter.	Clean out and inspect.
	Finger holder improperly adjusted.	Adjust to proper setting. (14 to 22 in. lbs. rolling torque)
	Broken fingers.	Replace fingers and/or springs as required.
	Planting too slowly.	Increase planting speed to within recommended range.
Planting too many doubles.	Planting too fast.	Stay within recommended speed range.
	Loose finger holder.	Adjust to specs. (14 to 22 in. lbs. rolling torque)
	Worn brush in carrier plate.	Inspect and replace if necessary.
Over planting.	Worn carrier plate.	Inspect and replace if necessary.
	Seed hopper additive being used.	Reduce or eliminate additive or increase graphite.
Under planting.	Belt installed backwards.	Remove and install correctly.
	Weak or broken springs.	Replace.
	Spring not properly installed.	Remove finger holder and correct.
	Seed belt catching or dragging.	Replace belt.
	Brush dislodging seed.	Replace brush.
Irregular or incorrect seed spacing.	Driving too fast.	Check chart for correct speed.
	Wrong tire pressure.	Inflate tires to correct air pressure.
	Drive wheels slipping.	Reduce down pressure on row unit down force springs.
	Wrong sprockets.	Check seed rate charts for correct sprocket combinations.
Seed spacing not as indicated in charts.	Wrong tire pressure.	Inflate tires to correct air pressure.
	Inconsistent seed size.	Do field check and adjust sprockets accordingly.
	Wrong sprockets.	Check chart for correct sprocket combination.
	Charts are approximate.	Slight variations due to wear in meter components and tire slippage due to field conditions may produce seed spacing variations.
	Stiff or worn drive chains.	Replace chains.
Scattering of seeds.	Planting too fast.	Reduce planting speed.
	Seed tube improperly installed.	Check seed tube installation.
	Seed tube worn or damaged.	Replace seed tube.
Seed tubes and/or openers plugging.	Allowing planter to roll backward when lowering.	Lower planter only when tractor is moving forward.
Inconsistent seed depth.	Rough seed bed.	Adjust down pressure springs. Reduce planting speed.
	Partially plugged seed tube.	Inspect and clean.
	Seed tube improperly installed.	Install properly.

MAINTENANCE

BRUSH-TYPE SEED METER MAINTENANCE

60607-10

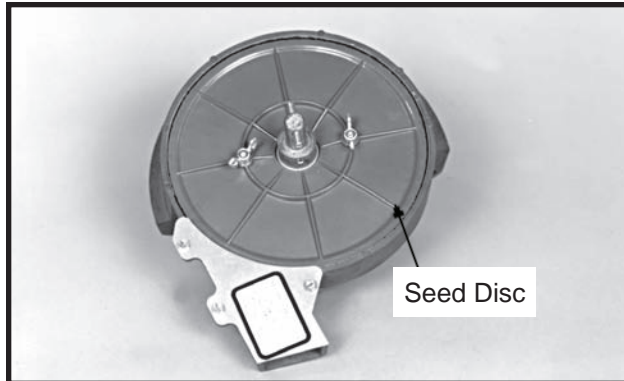

60607-3

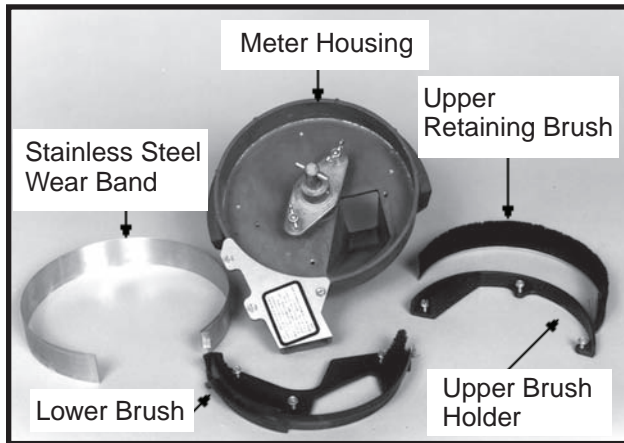

Only clean, high quality seed should be used for maximum meter accuracy. Damaged or cracked seed, hulls or foreign materials may become lodged in the upper seed retaining brush and greatly reduce meter accuracy. It is suggested that the seed disc be removed daily, inspected and cleaned. Check for buildup of foreign material on the seed disc, particularly in the seed loading slots. Clean the disc by washing it with soap and water. Check for cracked seed, hulls, etc. lodged between the brush holder and stainless steel wear band which can greatly reduce the accuracy of the meter because the retaining brush will not be able to retain the seed in the seed disc pocket. Use compressed air to clean the brush areas of the meter housing.

60607-8/60607-8L

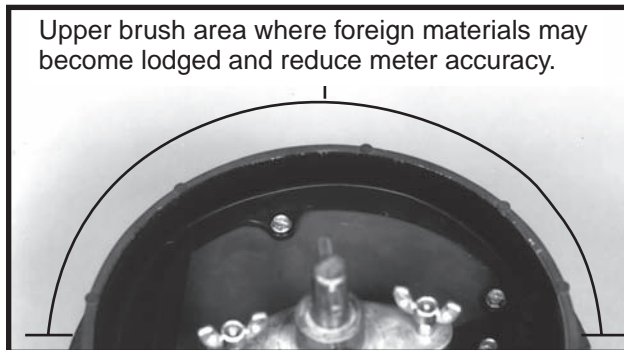

NOTE: Replace hopper lids after hoppers are filled to prevent accumulation of dust or dirt in the seed meter which will cause premature wear.

Cleaning Brush-Type Seed Meter for storage:

1. Remove meter from seed hopper by removing the two nuts which secure the meter to the hopper.
2. Remove seed disc and wash with soap and water and dry thoroughly.
3. Remove upper retaining brush by removing the three hex head screws from the brush holder and removing brush holder and retaining brush.
4. Remove the three hex head screws from the lower brush and remove lower brush and stainless steel wear band.
5. Wash all parts and meter housing with soap and water and dry thoroughly.
6. Inspect all parts for wear and replace worn parts.
7. Reassemble meter except for seed disc. **Meter should be stored in a rodent-free space with seed disc removed.**

Seed Disc Wear

(PLTR40b)

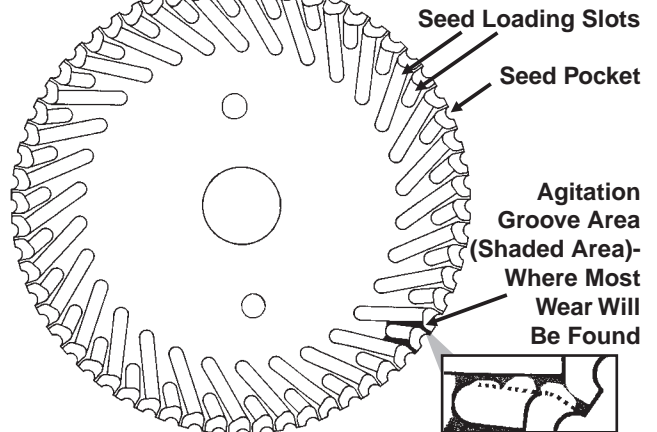

Most wear on the seed disc will be found in the agitation groove area (area between the seed loading slots). Wear will affect planting accuracy at high RPM. To measure for wear, lay a straight edge across the surface of the disc and measure the gap between the disc (at the agitation groove area) and the straight edge. If the agitation groove areas are worn in excess of .030" and accuracy starts to drop off at higher meter RPM, the seed disc should be replaced.

Estimated life expectancy of the seed disc under normal operating conditions should be approximately 200 acres per row. Severe operating conditions such as dust, lack of lubrication or abrasive seed coating could greatly reduce life expectancy of the seed disc.

MAINTENANCE

Upper Retaining Brush

60607-21

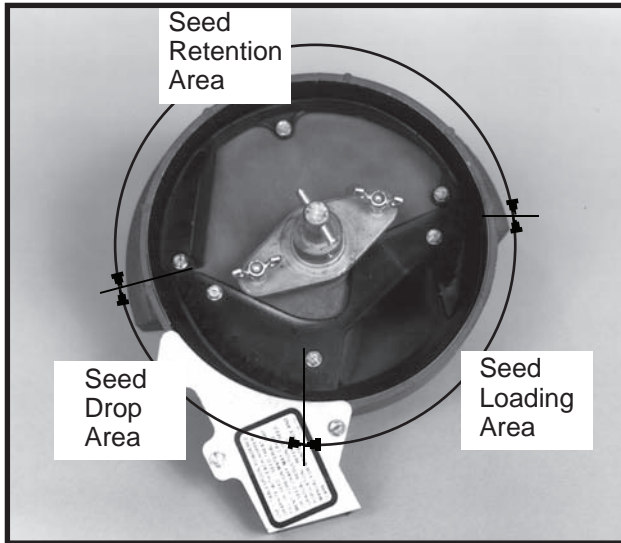

The upper retaining brush holds seed in the seed disc pocket in the seed retention area.

The retaining brush must apply enough pressure against the seed in the seed disc pocket as the disc rotates through the seed retention area to prevent the seed from dropping out of the disc pocket. A damaged spot, excessive wear on the brush or foreign material lodged in the brush may greatly reduce meter performance.

The upper retaining brush should be replaced at approximately 120-400 acres per row of use or sooner if damage or excessive wear is found.

Installation Of Upper Retaining Brush

Position retaining brush into inner perimeter of seed retention area. Make sure the base of the brush is tight against the bottom of the meter housing. Install brush holder and three hex head screws. Tighten center screw first, left screw second and right screw last.

60607-21

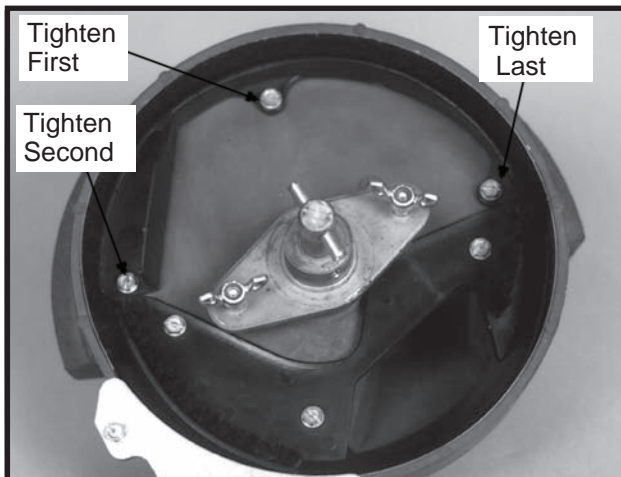

Stainless Steel Wear Band

60607-38a

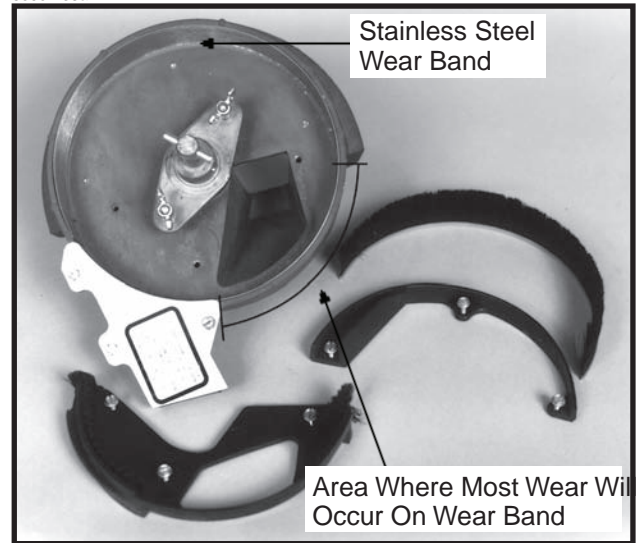

The purpose of the stainless steel wear band is to protect the meter housing from wear. The band is .030" thick and should be replaced when approximately .020" of wear is found in the primary area of wear. If the wear band is allowed to wear through or if the meter is used without the wear band in place, damage to the meter housing may occur.

Estimated life expectancy of the stainless steel wear band is 240-800 acres per row.

Lower Brush

60607-3

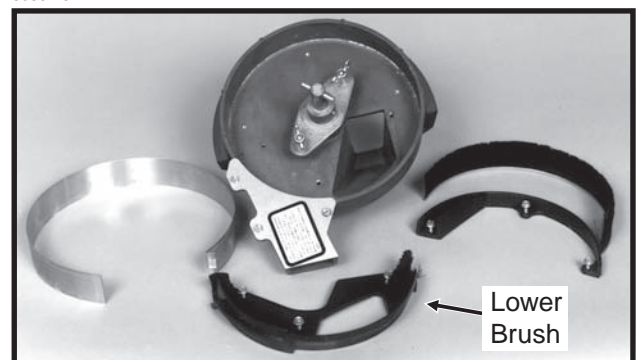

The lower brush has several functions. One function is to move seed down the seed loading slots to the seed pockets. The second function is to isolate seed in the reservoir from entering the seed tube and a third is to clean the seed loading slots.

Estimated life expectancy of the lower brush is 240-800 acres per row. The lower brush should be replaced if the bristles are deformed or missing or if there are cracks in the brush holder.

MAINTENANCE

BRUSH-TYPE SEED METER TROUBLESHOOTING

PROBLEM	POSSIBLE CAUSE	SOLUTION
Low count.	Meter RPM too high.	Reduce planting speed.
	Misalignment between drive clutch and meter.	See "Seed Meter Drive Adjustment".
	Seed sensor not picking up all seeds dropped.	Clean seed tube. Switch meter to different row. If problem stays with same row, replace sensor.
	Lack of lubrication causing seeds not to release from disc properly.	Use graphite or talc as recommended.
	Seed size too large for seed disc being used.	Switch to smaller seed or appropriate seed disc. See "Brush-Type Seed Meter" for proper seed disc for size of seed being used.
	Seed treatment buildup in meter.	Reduce amount of treatment used and/or thoroughly mix treatment with seed.
Low count at low RPM and higher count at higher RPM.	Foreign material lodged in upper retaining brush.	Remove seed disc and remove foreign material from between brush holder and bristles. Clean with compressed air.
	Worn upper retaining brush.	Replace. See "Maintenance".
Low count at higher RPM and normal count at low RPM.	Seed disc worn in the agitation groove area.	Replace disc. See "Maintenance".
High count.	Seed size too small for seed disc.	Switch to larger seed or appropriate seed disc.
	Incorrect seed rate transmission setting.	Reset transmission. Refer to proper rate chart in "Machine Operation" section of manual.
	Upper brush too wide (fanned out) for small seed size.	Replace upper brush.
Upper retaining brush laid back.	Seed treatment buildup on brush.	Remove brush. Wash with soap and water. Dry thoroughly before reinstalling. See "Maintenance".
	Buildup of foreign material at base of brush.	Remove brush holder and brush. Clean with compressed air. Reinstall.

CLOSING WHEEL TROUBLESHOOTING

PROBLEM	POSSIBLE CAUSE	SOLUTION
Closing wheel(s) leave severe imprint in soil.	Too much closing wheel down pressure.	Adjust closing wheel pressure.
Closing wheel(s) not firming soil around seed.	Insufficient closing wheel down pressure.	Adjust closing wheel pressure. Severe no till conditions may require use of cast iron closing wheels.
"V" closing wheel running on top of seed furrow.	Improper centering.	Align. See "V" Closing Wheel Adjustment.
Single closing wheel not directly over seed.	Improper centering.	Align. See "Covering Discs/Single Press Wheel Adjustment".

MAINTENANCE

GAUGE WHEEL ADJUSTMENT

To prevent an accumulation of dirt or trash, gauge wheels should lightly contact the opener blades. Gauge wheels and opener blades should turn with only slight resistance.

73090-24

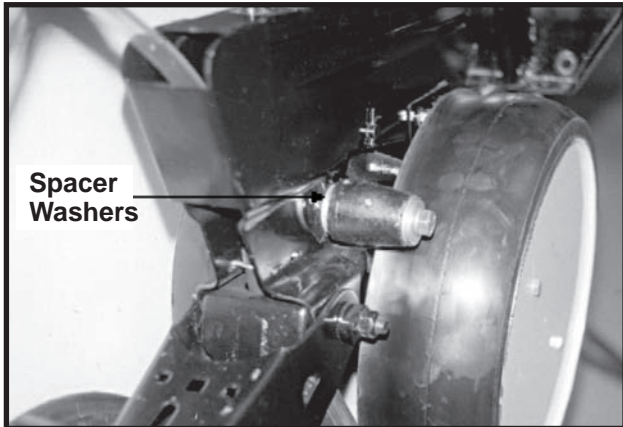

(RU61a)

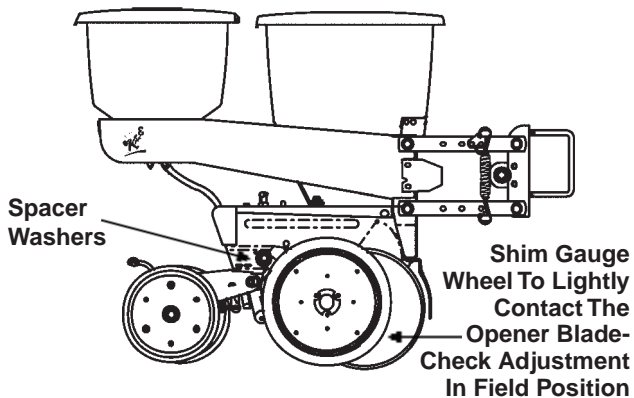

To adjust clearance between gauge wheels and opener blades, add or remove spacer washers between the shank and gauge wheel arm. Store remaining spacer washers between gauge wheel arm and flat washer on outer side of gauge wheel arm.

NOTE: It may be desirable to space gauge wheel further from blade when operating in sticky soils.

15" SEED OPENER DISC/BEARING ASSEMBLY

1"-2" of blade-to-blade contact should be maintained to properly open and form the seed trench. As the blade diameter decreases due to wear, it will be necessary to remove spacer washers to maintain 1"-2" of contact.

If 1"-2" of blade-to-blade contact cannot be maintained after removing spacer washers or if blade diameter wears below 14 1/2", the blade should be replaced.

(RU61a)

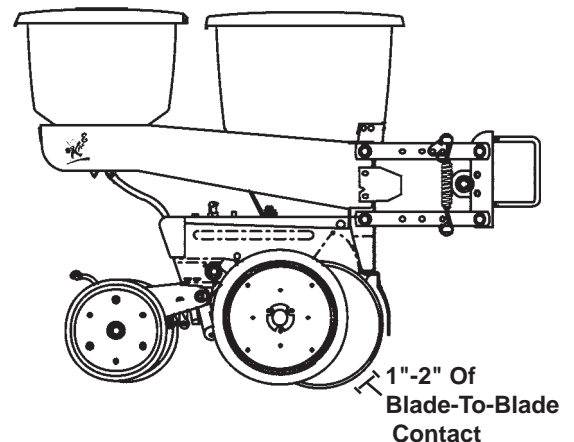

To replace disc/bearing assembly:

1. Remove gauge wheel.
2. Remove scraper.
3. Remove bearing dust cap.
4. Remove jam nut and washer from outside of disc/bearing assembly.

NOTE: Left hand side of opener uses a left hand threaded nut. **DO NOT OVER TIGHTEN.** Damage to mounting spindle will require replacement of row unit shank assembly.

5. Remove disc/bearing assembly. The spacer bushings between the shank and disc are used to maintain the 1"-2" blade-to-blade contact.
6. After installing new disc/bearing assembly, install washer and jam nut to secure disc/bearing assembly. Torque 5/8"-11 Grade 2 nut to value shown in "Torque Values Chart".
7. Replace bearing dust cap.
8. Install scraper.
9. Install gauge wheel.

It may be necessary to replace only the bearing if there is excessive endplay or if the bearing sounds rough when the disc is rotated.

To replace bearing:

1. Remove gauge wheel, scraper, bearing cap, jam nut, washer and disc/bearing assembly.
2. Remove 1/4" rivets from bearing housing to expose bearing.
3. After installing new bearing, install three evenly spaced 1/4" bolts into three of the six holes in the bearing housing to hold the bearing and bearing housing in place. Install rivets in the other three holes. Remove 1/4" bolts and install rivets in those three holes.
4. Reinstall disc/bearing assembly, washer and jam nut. Torque 5/8"-11 Grade 2 nut to value shown in "Torque Values Chart" at the beginning of this section.
5. Replace bearing dust cap.
6. Install scraper and gauge wheel.

MAINTENANCE

SEED TUBE GUARD/INNER SCRAPER

The seed tube guard protects the seed tube and acts as the inner scraper for the disc opener blades.

Remove the seed tube and check for wear. Excessive wear on the seed tube indicates a worn seed tube guard.

50881-9

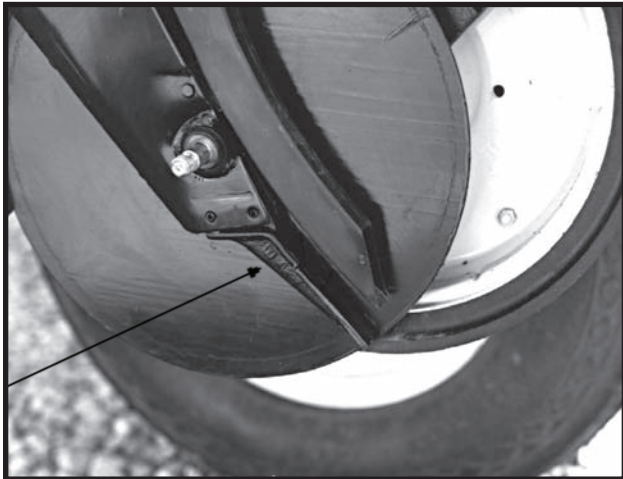

No till planting or planting in hard ground conditions will increase seed tube guard wear and necessitate more frequent inspection.

The gauge wheels and seed opener discs must be removed before the seed tube guard can be replaced.

ROW UNIT MOUNTED NO TILL COULTER

80367-10



Lubricate at frequency indicated in the Lubrication Section of this manual. Check periodically to be sure nuts and hardware are tightened to proper torque specification.

NOTE: Torque $\frac{5}{8}$ " spindle bolts to 120 ft. lbs.

Be sure the coulters are positioned square with the row unit and aligned in front of row unit disc opener.

The coulters can be adjusted to one of four settings. Initially the blade is set in the highest position. As the blade wears it can be adjusted to one of the three lower settings. See "Row Unit Mounted No Till Coulters" in Operation Section of this manual.

When the 16" diameter coulters blade is worn to a 14 $\frac{1}{2}$ " diameter (maximum allowable wear), it should be replaced.

Timely lubrication at the frequency indicated in the lubrication section of this manual is necessary to purge moisture and dirt from bearing and seal. This will also lubricate the seal. Add grease until it comes out around the seal.

NOTE: Add grease until it comes out around the seal. Spin hub while filling with grease.

MAINTENANCE

ELECTRONIC SEED MONITOR SYSTEM TROUBLESHOOTING

LFD2-96/LFD1-96



The general procedure to use, if a problem occurs, is to isolate the cause to a sensor, sensor lead, planter harness, console cable or the console, in that order. Make necessary repairs after problem has been isolated.

1. Sensors

Check for excessive dirt inside sensor. Check for cut or damaged wires. Connect sensor to the planter harness in a row that is operating properly. If it then operates correctly, sensor is good.

In some cases static electricity may cause dust and seed treatment to accumulate on the sensing elements in the sensor. Enough may accumulate to cause the sensor to malfunction, which can cause monitor to indicate a fault condition. Low humidity and dry soil conditions tend to cause this condition. When this occurs, clean the inside of the sensors, using a dry bottle brush.

If, for any reason a sensor becomes inoperative and a replacement sensor is not immediately available, disconnect the sensor lead connector from the planter harness, turn monitor OFF and then back ON. This will keep the alarm from sounding for this row only. Replace the defective seed sensor (using high rate seed sensor only) as soon as possible. After sensor is replaced make certain the monitor is turned OFF and back ON to reactivate the sensor position.

If sensor leads are damaged, carefully cut away the cable covering at the damaged area. Repair damaged wire or wires by soldering wires together with rosin core solder, being sure to match wire colors, then tape each repaired wire. Finally, tape over cut portion of the cable cover. If necessary, relocate and secure cable so that the same type of damage will not occur again.

2. Planter Harness And Console Cable

Carefully examine planter harness and console cable for damage. If harness and/or cable is cut or pinched, carefully cut away the harness/cable covering. Repair cut or damaged wire by soldering wires together with rosin core solder, being sure to match wire colors. Tape each repaired wire, then tape over cut harness/cable covering. If necessary, relocate and secure harness/cable so that the same type damage will not occur again.

3. Console

Check for a blown fuse, located on the console rear panel. Check battery connections and make certain they are clean and tight. Make certain battery is fully charged.

If console fuse is blown replace with a 5 amp type AGC. If fuse blows again, console needs repair or replacement.

CAUTION: DO NOT REPLACE FUSE WITH A FUSE HAVING A HIGHER AMPERAGE RATING.

If the battery cable is not damaged, battery connections are clean and tight and the battery is fully charged, the console is defective and needs to be repaired or replaced.

MAINTENANCE

KM1000 TROUBLESHOOTING CHART

PROBLEM	POSSIBLE CAUSE	SOLUTION
1. Low Voltage Indicator is ON.	Connected to 6 volt battery.	Connect to 12 volt battery.
	System voltage insufficient.	Insure greater than 11.0 volts.
	Battery connection corroded.	Inspect battery connections. If console power cable terminals or battery terminals are dirty or corroded, clean terminals as required.
	Console defective.	Repair or replace console. Contact your KINZE® Dealer.
2. One row indicator lamp fails to flash when planting. Alarm does not sound.	Burned out row indicator lamp.	Replace row indicator lamp with a No. 1892 lamp only. (Part No. GR0595).
3. One row indicator lamp fails to flash when planting. Alarm sounds continuously. Seeds are being planted by the row unit.	Sensing elements inside seed sensor are dirty.	Clean sensing elements using a dry bottle brush. NOTE: Some seed treatment chemicals are detrimental to the operation of seed sensors and refuse to be removed by dry brushing. To remove such treatment from the inside of a sensor, proceed as follows: Wet a bottle brush with water, then apply a moderate amount of kitchen cleanser (such as Ajax® or Comet®) to the brush. Scrub inside of sensor until treatment is removed, then rinse sensor in clear cold water. Dry thoroughly.
	Defective sensor.	Plug suspect sensor cable into an adjacent row that is operating correctly. If sensor does not operate, sensor is defective. If you wish to continue planting and a replacement sensor is not available, disconnect the defective sensor cable from the planter harness, turn the monitor OFF and then back ON. The monitor will ignore the disconnected row sensor and you can continue to monitor all other rows.

MAINTENANCE

KM1000 TROUBLESHOOTING CHART (Continued)

PROBLEM	POSSIBLE CAUSE	SOLUTION
<p>4. One row indicator lamp fails to come on when the console is powered up.</p>	<p>Burned out row indicator lamp.</p>	<p>Replace row indicator lamp with a number 1892 lamp only. (Part No. GR0595)</p>
	<p>Defective seed sensor or planter harness.</p>	<p>Disconnect the suspected sensor from the planter harness row lead. Disconnect the sensor from the planter harness of an adjacent row. Reverse the harness row leads to the sensors (connect the suspected sensor to the adjacent row planter harness lead and the adjacent sensor to the suspected row harness lead).</p> <p>Turn console power OFF then back ON. If the symptom moves to the adjacent row, the seed sensor is defective and needs replaced. If the symptom does not move, the planter harness or console is defective and needs repaired. Visually inspect the planter harness for cuts, pinching, etc., if damage is found, repair by cutting away the cable covering and splicing the wires (being sure to match wire colors). Solder the splices and tape each wire individually. Tape over repaired cable.</p>
	<p>Console defective.</p>	<p>Repair or replace console. Contact your KINZE® Dealer.</p>
<p>5. Monitor completely "dead".</p>	<p>Blown fuse.</p>	<p>Check fuse, located on rear panel of console. If fuse is blown, replace with a 5-amp, type AGC. If fuse blows again, check power connection to battery. If connections are reversed fuse will blow. If battery connections are correct, console needs repair or replacement. Contact your KINZE® Dealer.</p>
	<p>Poor battery connections.</p>	<p>Check battery connections. Connections must be clean and tight.</p>

MAINTENANCE

KM1000 TROUBLESHOOTING CHART (Continued)

PROBLEM	POSSIBLE CAUSE	SOLUTION
5. (Cont'd.)	Cut or broken battery cable. cable for a cut or broken wire.	Visually inspect the battery If wires are cut or broken, splice the wires being sure to match wire colors. Solder the splices and tape each wire individually. USE ONLY ROSIN CORE SOLDER.
	Console defective.	Repair or replace console. Contact your KINZE® Dealer.
6. When monitor is turned ON, row indicator lamps are dark, green power indicator is ON and monitor will not enter operate mode.	Console not connected to planter harness.	Connect console cable to planter harness.
	Defective (shorted) seed sensor.	Leave monitor turned on. Unplug seed sensors one at a time starting with row 1. When you disconnect a sensor and the remaining row indicator lamps come on, the sensor or its cable is defective. Visually inspect the sensor cable. If damaged, repair. If no cable damage is found, the sensor is defective and needs to be replaced. If all but the last sensor is disconnected and the problem still exists, reconnect a sensor before disconnecting the last sensor. If the last sensor is disconnected and the problem still exists, the planter harness, console cable or console is at fault.
	Planter harness shorted.	Visually inspect the planter harness (including all row unit cables) for cuts, pinching and other types of damage. If damage is found, cut away cable covering and repair the individual wires. Tape over repaired wire and cable.
	Console defective.	If the console cable, planter harness, and seed sensors are normal, the console is at fault and needs to be repaired or replaced. Contact your KINZE® Dealer.

MAINTENANCE

KM3000 TROUBLESHOOTING CHART

PROBLEM	POSSIBLE CAUSE	SOLUTION
1. Display readout incomplete (fragmented) alarm sounds continuously.	Low battery voltage.	Recharge or replace battery.
	Battery connections corroded.	Inspect battery connection. If console power cable terminals or battery terminals are dirty or corroded, clean terminals as required.
	Console defective.	Repair or replace console. Contact your KINZE® Dealer.
2. One row indicator segment (lower display) fails to flash when planting. Population readout for the planter row is .0. Alarm sounds continuously. Seeds are being planted by the row unit.	Sensing elements inside seed sensor are dirty.	Clean sensing elements using a dry bottle brush. NOTE: Some seed treatment chemicals are detrimental to the operation of seed sensors and refuse to be removed by dry brushing. To remove such treatment from the inside of a sensor proceed as follows: Wet a bottle brush with water, then apply a moderate amount of kitchen cleanser (such as Ajax® or Comet®) to the brush. Scrub inside of sensor until treatment is removed, then rinse sensor in clear cold water. Dry thoroughly.
	Defective sensor.	Plug suspect sensor cable into an adjacent row that is operating correctly. If sensor does not operate, sensor is defective. If you wish to continue planting and a replacement sensor is not available, disconnect the defective sensor cable from the planter harness, turn the monitor OFF and then back ON. The monitor will ignore the disconnected row sensor and you can continue to monitor all other rows.
3. Display will not accumulate area planted.	Both radar ground and magnetic distance sensors are connected to the monitor at the same time.	Disconnect either the radar ground sensor or the magnetic distance sensor.

MAINTENANCE

KM3000 TROUBLESHOOTING CHART (Continued)

PROBLEM	POSSIBLE CAUSE	SOLUTION
4. Monitor completely "dead".	Blown console fuse.	Check fuse, located on rear panel of console. If fuse is blown, replace with a 5-amp, type AGC. If fuse blows again, check power connection to battery. If connections are reversed fuse will blow. If battery connections are correct, console needs to be repaired or replaced. Contact your KINZE® Dealer.
	Poor battery connections.	Check battery connections. Connections must be clean and tight.
	Cut or broken battery cable.	Visually inspect the battery cable for a cut or broken wire. If wires are cut or broken, splice the wires being sure to match wire colors. Solder the splices and tape each wire individually. USE ONLY ROSIN CORE SOLDER.
	Low battery voltage.	Check battery voltage. Must be at least 12 volts. If not, recharge or replace battery.
	Console defective.	Repair or replace console. Contact your KINZE® Dealer.
5. When monitor is turned ON, row display (lower display) remains blank. Upper display shows SPEED, NUMBER OF ROWS, and ROW SPACING constants. Monitor will not enter OPERATE mode.	Console not connected to planter harness.	Connect console cable to planter harness.
	Defective (shorted) seed sensor.	Leave monitor turned ON. Unplug seed sensors one at a time starting with row 1. When you disconnect a sensor and the remaining row display segments come on and the monitor enters the operate mode, the sensor or its cable is defective. Visually inspect the sensor cable. If damaged repair. If no cable damage is found, the sensor is defective and needs replaced. If all sensors are disconnected and problem still exists, the planter harness, console cable or console is at fault.

MAINTENANCE

KM3000 TROUBLESHOOTING CHART (Continued)

PROBLEM	POSSIBLE CAUSE	SOLUTION
5. (Cont'd.) When monitor is turned ON, row display (lower display) remains blank. Upper display shows SPEED, NUMBER OF ROWS, and ROW SPACING constants. Monitor will not enter OPERATE mode.	Planter harness shorted.	Visually inspect the planter harness (including all row unit cables) for cuts, pinching and other types of damage. If damage is found, cut away cable covering and repair the individual wires. Tape over repaired wire and cable.
	Console cable shorted.	Visually inspect the console cable for cuts, pinching and other types of damage. If damage is found, cut away cable covering and repair the individual wires. Tape over repaired wire and cable.
	Console defective.	If the console cable, planter harness and seed sensors are normal, the console is at fault and needs to be repaired or replaced. Contact your KINZE® Dealer.

SEED MONITOR ROW INDICATOR BULB REPLACEMENT (KM1000 Only)

D-0802-0002/D-0802-0003(PLTR41)

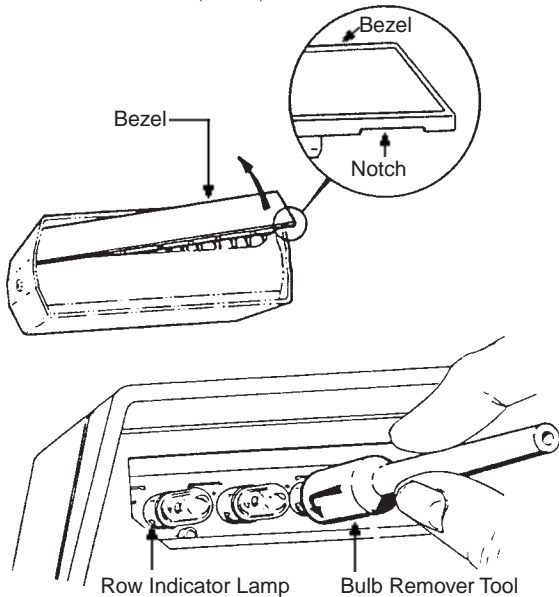

Carefully remove the row indicator bezel as shown. Use your fingernail to pry up along the lower outside edge of the bezel. Remove bezel. Remove burned out bulb using a bulb remover tool. Press in on bulb, turn ¼ turn counterclockwise and remove bulb. Replace bulb with a No. 1892 (Part No. GR0595) only. Install bezel.

SEED MONITOR DISPLAY BACKLITE BULB REPLACEMENT (KM3000 Only)

D-0841-0006(PLTR42)

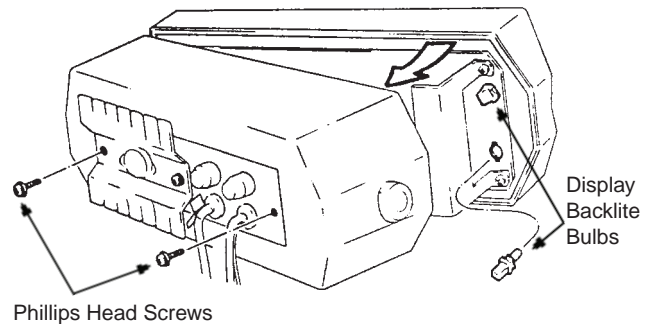

Remove the two outside Phillips head screws. NOTE: DO NOT REMOVE THE CENTER PHILLIPS HEAD SCREW. Carefully separate the console case from the front panel. Remove the defective bulb by turning the lamp assembly ¼ turn counterclockwise and pulling straight out. Replace bulb with a GE No. 73 bulb (Part No. GR1084). Carefully assemble the console front panel, case and rear panel and install the two Phillips head screws. **CAUTION: Make sure that all wires are located where they will not be pinched or cut.**

MAINTENANCE

POINT ROW WRAP SPRING CLUTCH INSPECTION

The point row wrap spring clutch is permanently lubricated and sealed and requires no periodic maintenance.

81014-12

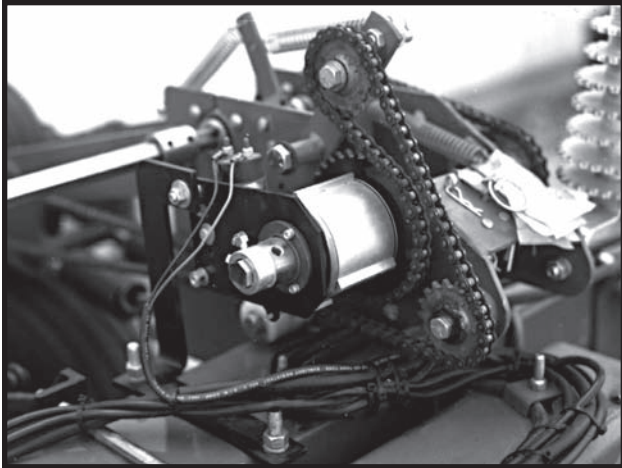

The right hand clutch operates clockwise and the left hand clutch operates counterclockwise. Therefore, some of the parts of the clutch such as the wrap spring differ from one side of the planter to the other. Be sure to use the correct repair part if a clutch must be repaired.

The control box is equipped with a resettable circuit breaker. To reset the circuit breaker, press the red button on the circuit breaker until it snaps into place. If the circuit breaker continues to trip, check to see what is causing it to trip. See "Point Row Clutch Troubleshooting."

76740-48

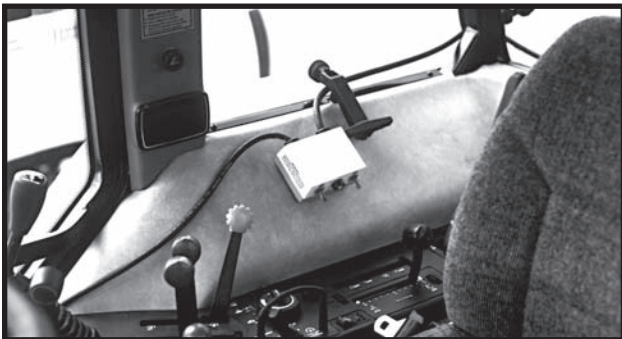

If the circuit breaker on the control box is not tripped, determine if the problem is electrical or mechanical. Place the operational switch in the RIGHT or LEFT position. Check the clutch and wiring harness for power with a test light or volt meter. If the solenoid is operating properly, the plunger on the solenoid will retract causing a clicking sound. The plunger will also be magnetized which can be checked by touching the plunger with a metal object.

PRC019/PRC020(SFP5)

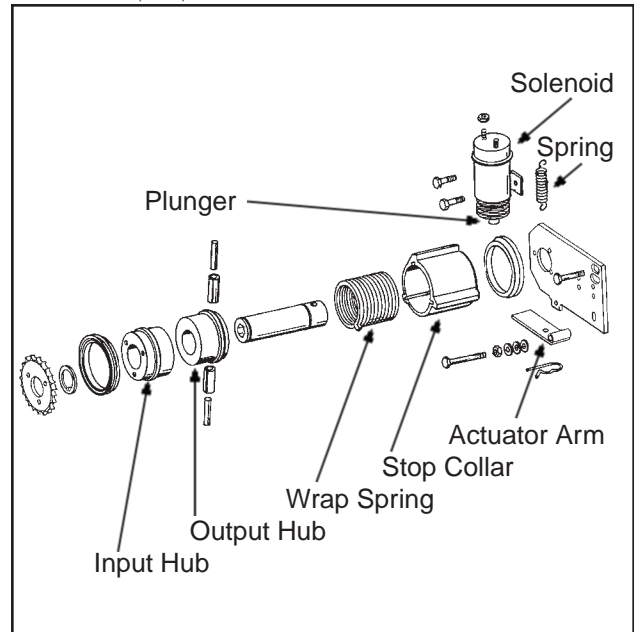

A7418(SFP12)

ACTUATOR ARM ADJUSTMENT

NOTE: Gap between actuator arm and stop on stop collar should be $\frac{1}{8}$ " ($\pm\frac{1}{32}$ ") when the solenoid is NOT engaged.

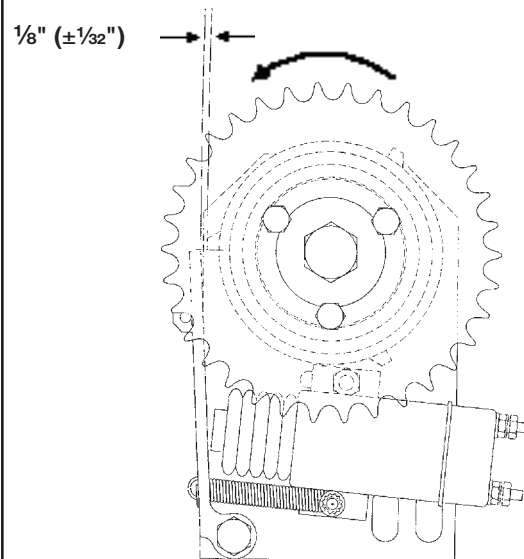

NOTE: To adjust gap between actuator arm and stop, loosen nut on mounting pin and move pin in slot until there is $\frac{1}{8}$ " ($\pm\frac{1}{32}$ ") gap between arm and stop on stop collar. Retighten nut.

MAINTENANCE

POINT ROW WRAP SPRING CLUTCH TROUBLESHOOTING

PROBLEM	POSSIBLE CAUSE	SOLUTION
Neither clutch will disengage.	Circuit breaker tripped.	Press red button on control box.
	Poor terminal connection in wiring harness.	Repair or replace.
	Wiring damage in wiring harness.	Repair or replace.
	Low voltage at coil. (12 volts required)	Check battery connections.
One side of planter will not re-engage.	Shear pin in row unit transmission sheared.	Replace with one of equal size and grade.
One clutch will not engage.	Actuator arm and plunger stuck in disengaged position.	Remove, free up and reinstall.
	Actuator arm out of adjustment.	Adjust actuator arm mounting pin in slot so that actuator arm clears stop on stop collar as shown in "Point Row Wrap Spring Clutch Inspection".
	Wrap spring broken or stretched.	Disassemble clutch and replace spring.
	Foreign substance such as oil or grease on the input or output hubs.	Disassemble clutch. Clean hubs and spring and reassemble.
	Something touching the stop collar.	Check to ensure collar is free to turn with clutch.
	Clutch assembled incorrectly.	Check clutch and diagram for correct assembly.
Clutch slipping.	Wrap spring stretched.	"Lock" clutch output shaft from turning. Place torque wrench on input shaft and rotate in direction of drive. After input shaft has rotated a short distance the wrap spring should tighten onto the input hub. If slippage occurs at less than 100 ft. lbs. replace spring. If spring still slips after installing new spring, replace input hub.
Planter will not re-engage while planter is moving forward. away from stop collar when	Spring in actuator arm not strong enough to push arm spring. If that fails, file the stop operational switch is turned to the ON position.	Remove spring from inside solenoid and stretch spring slightly or replace. Reinstall spring. If that fails, file the stop on the stop collar slightly so that the stop is not as aggressive.
Frequent fuse burnout.	Low voltage (12 volts required).	Check power source voltage for partially discharged battery, etc.
	Damage to wiring harness.	Locate damage and repair or replace harness.
Clutch or clutches will not disengage.	Input and output shafts out of alignment.	Align input and output shafts to prevent drag.
	Input or output shaft is pushed in too far creating a coupler.	Reposition input and output shafts.

MAINTENANCE

TWO-SPEED POINT ROW WRAP SPRING CLUTCH

The two-speed point row wrap spring clutch is similar in design and operation to the standard point row wrap spring clutch except for the two-speed function. If a two-speed clutch or clutches fail to operate properly, refer to “Point Row Wrap Spring Clutch Inspection” and “Point Row Wrap Spring Clutch Troubleshooting” for additional information.

NOTE: If the “Reduced Rate/Full Rate” functions fail to engage or disengage, see troubleshooting chart for possible cause.

(SFP45)

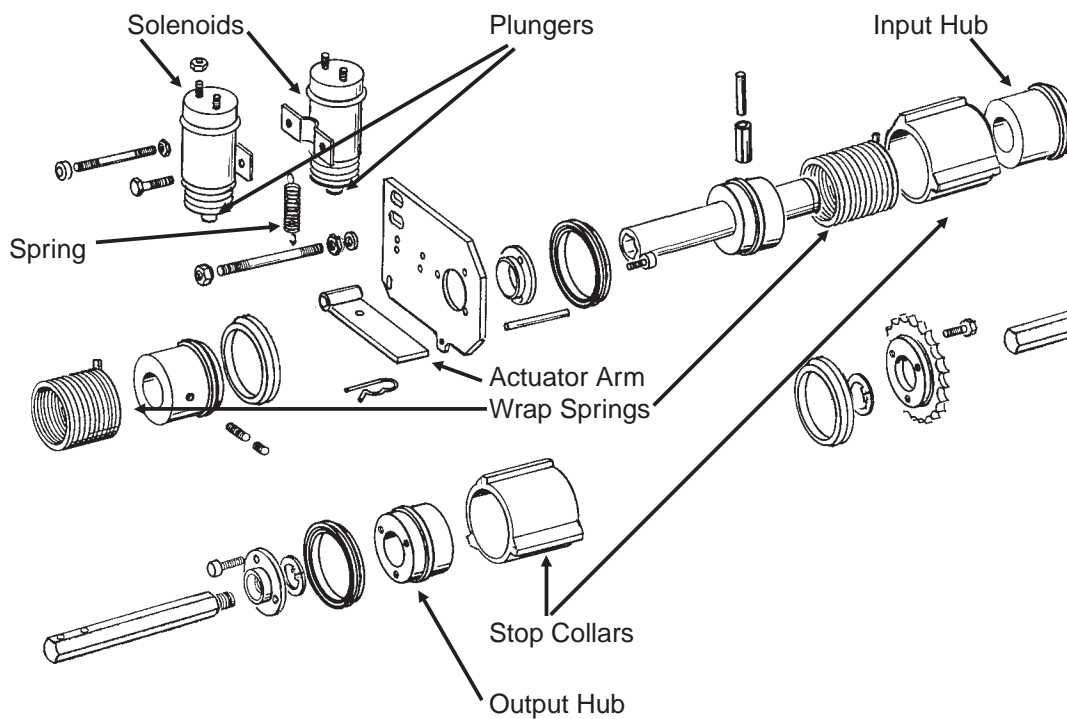

MAINTENANCE

CAM FOLLOWER ADJUSTMENT

Each wing hinge is equipped with a cam follower which floats against a curved guide on the center frame. Check cam followers periodically and maintain adjustment as shown below.

NOTE: Always check cam follower adjustment and make cam follower adjustments with the planter on a flat surface and lowered to the planting position.

A7386(SFP41)

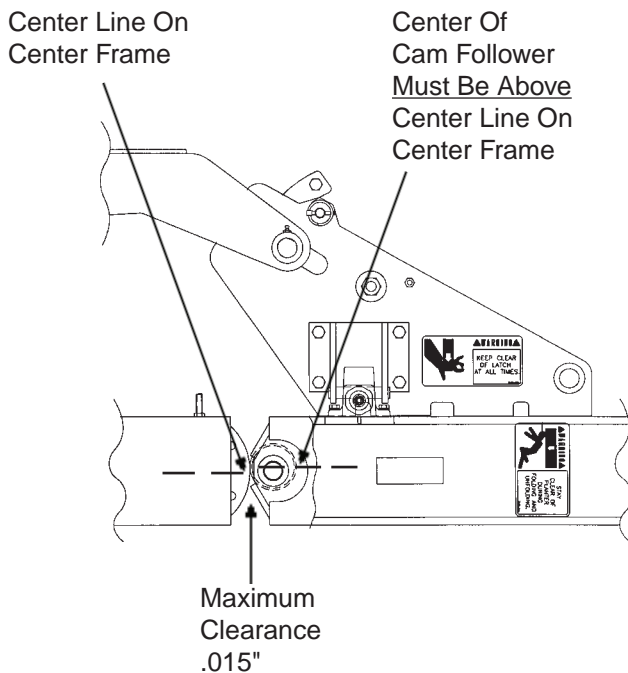

To adjust cam followers:

1. Loosen $\frac{3}{4}$ " cap screw on cam follower.
2. Using a $\frac{1}{2}$ " ratchet extension, rotate and hold cam follower in place.
3. Tighten $\frac{3}{4}$ " cap screw to 150 ft. lbs.

FLOW CONTROL VALVE INSPECTION

The optional dual lift assist wheels flow control valve should be adjusted as part of the assembly procedure or upon initial operation.

If the valve fails to function properly or requires frequent adjustment, the needle valve should be removed for inspection. Check for foreign material and contamination on both the valve and the seating area of the valve body. Replace any components found to be defective.

NOTE: The flow control valve must be installed with the arrow pointed toward the planter.

NOTE: When oil is cold, hydraulics operate slowly. Make sure all adjustments are made with warm oil.

WB001 (MT2)

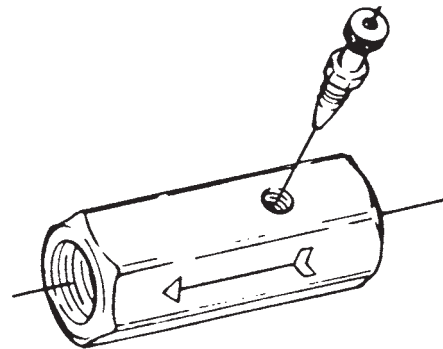

MAINTENANCE

MARKER SEQUENCING/FLOW CONTROL VALVE INSPECTION

The valve block assembly consists of the marker sequencing and flow control valves in one assembly.

The sequencing valve portion consists of a chambered body containing a spool and series of check valves to direct hydraulic oil flow. Should the valve malfunction, the components may be removed for inspection.

1. Remove valve block assembly from planter.
2. Remove detent assembly and port adapter assemblies from rear of valve block.

IMPORTANT: Damage to the spool may occur if the detent assembly and port adapter assemblies are not removed prior to removal of the spool.

3. Remove plug from both sides of valve block and remove spool.
4. Inspect all parts for pitting, contamination or foreign material. Also check seating surfaces inside the valve. Replace any parts found to be defective.
5. Lubricate spool with a light oil and re-install. Check to be sure spool moves freely in valve body.

IMPORTANT: Make sure correct ball(s) and spring are installed in each valve bore upon reassembly.

A flow control valve is located on each side of the block assembly. The flow control valves should be adjusted for raise and lower speed as part of the assembly procedure or upon initial operation. If the valve fails to function properly or requires frequent adjustment, the needle valve should be removed for inspection. Check for foreign material and contamination. Be sure needle moves freely in adjustment screw. Replace any component found to be defective.

(PLTR43)

Port Adapter, Spring, 7/16" Check Ball, 1/4" Steel Ball

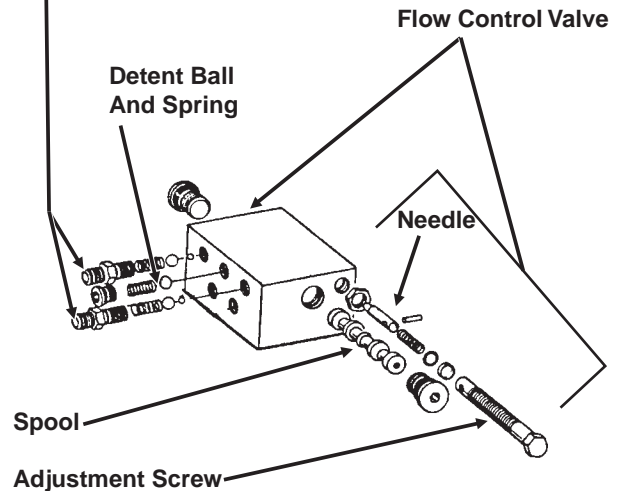

NOTE: When oil is cold, hydraulics operate slowly. Make sure all adjustments are made with warm oil.

MAINTENANCE

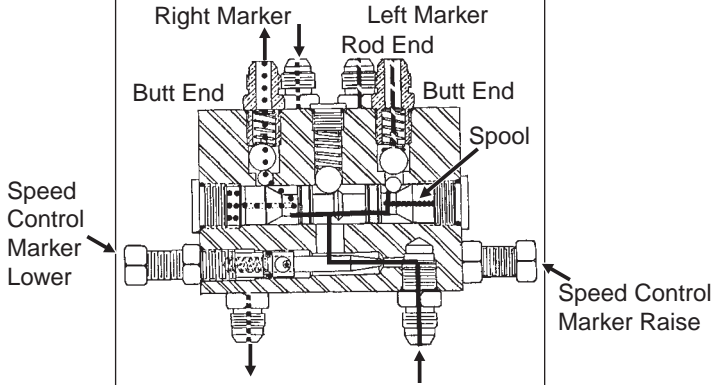
MARKER OPERATION TROUBLESHOOTING		
PROBLEM	POSSIBLE CAUSE	SOLUTION
Both markers lowering and only one raising at a time.	Hoses from cylinders to valve connected backwards.	Check hosing diagram in manual and correct.
Same marker always operating.	Spool in sequencing valve not shifting.	Remove spool, inspect for foreign material, making sure all ports in spool are open. Clean and reinstall.
		
Both markers lower and raise at same time.	Foreign material under check ball in sequencing valve.	Remove hose fitting, spring and balls and clean. May be desirable to remove spool and clean as well.
	Check ball missing or installed incorrectly in sequencing valve.	Disassemble and correct. See illustration in Parts Section.
Marker (in raised position) settling down.	Damaged o-ring in marker cylinder or cracked piston.	Disassemble cylinder and inspect for damage and repair.
	Spool in sequencing valve not shifting completely because detent ball or spring is missing.	Check valve assembly and install parts as needed.
	Spool in sequencing valve shifting back toward center position.	Restrict flow of hydraulic oil from tractor to sequencing valve.
Neither marker will move.	Flow control closed too far. counterclockwise until desired	Loosen locking nut and turn flow control adjustment bolt out or speed is set.
Markers moving too fast.	Flow control open too far.	Loosen locking nut and turn flow control adjustment bolt in or clockwise until desired speed is set.
Sporadic marker operation speed.	Needle sticking open in flow control valve.	Remove flow control, inspect and repair or replace.

MAINTENANCE

MARKER BEARING LUBRICATION OR REPLACEMENT

1. Remove marker blade.
2. Remove dust cap from hub.
3. Remove cotter pin, nut and washer.
4. Slide hub from spindle.
5. Remove bearings and cups and discard if bearings are being replaced. Clean hub and dry. Remove bearings only and not cups if repacking.
6. Press in new bearing cups with thickest edge facing in. (Bearing replacement procedure only.)
7. Pack bearings with heavy duty wheel bearing grease thoroughly forcing grease between roller cone and bearing cage. Also, fill the space between the bearing cups in the hub with grease.
8. Place inner bearing in place and press in new rubber seal and grease seal.
9. Clean spindle and install hub.
10. Install outer bearing, washer and slotted hex nut. Tighten slotted hex nut while rotating hub until there is some drag. This assures that all bearing surfaces are in contact. Back off slotted nut to nearest locking slot and install cotter pin.
11. Fill dust caps approximately $\frac{3}{4}$ full of wheel bearing grease and install on hub.
12. Install blade and dust cap retainer on hub and tighten evenly and securely.

(PLTR45/PLTR99/PLTR98/PLTR102)

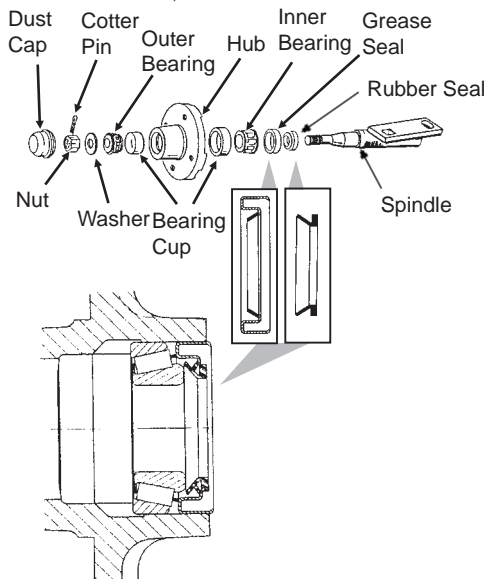

WHEEL BEARING LUBRICATION OR REPLACEMENT

1. Raise tire clear of ground and remove wheel.
2. Remove double jam nuts and slide hub from spindle.
3. Remove bearings and cups and discard if bearings are being replaced. Clean hub and dry. Remove bearings only and not cups if repacking.
4. Press in new bearing cups with thickest edge facing in. (Bearing replacement procedure only.)
5. Pack bearings with heavy duty wheel bearing grease thoroughly forcing grease between roller cone and bearing cage. Also fill the space between the bearing cups in the hub with grease.
6. Place inner bearing and seal (Where Applicable) in place.
7. Clean spindle and install hub.
8. Install outer bearing and jam nut. Tighten jam nut while rotating hub until there is some drag. This assures that all bearing surfaces are in contact. Back off jam nut $\frac{1}{4}$ turn or until there is only slight drag when rotating the hub. Install second jam nut to lock against first.
9. Install wheel on hub. Tighten wheel bolts evenly and torque to value shown in "Torque Values Chart" at the beginning of this section.

PTD057(EF35e)

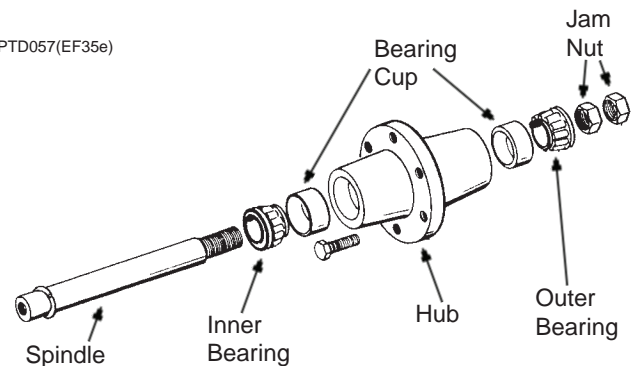

MAINTENANCE

PREPARATION FOR STORAGE

Store the planter in a dry sheltered area if possible.

Remove all trash that may be wrapped on sprockets or shafts and remove dirt that can draw and hold moisture.

Clean all drive chains and coat with a rust preventative spray, or remove chains and submerge in oil.

Lubricate planter and row units at all lubrication points.

If possible, remove weight from all tires particularly if the unit is stored outdoors, in which case it is best to remove wheels and tires for storage in a cool dry area.

Inspect the planter and row units for parts that are in need of replacement and order during the "off" season.

Make sure all seed, herbicide and insecticide hoppers are empty and clean.

Clean seed meters and store in a rodent-free dry area.

Remove seed discs from brush-type seed meter, clean and store meters with discs removed.

Grease exposed areas of cylinder rods before storing planter.

Grease or paint disc openers and marker blades to prevent rust.

Disassemble, clean and grease all U-joint slides.

ELECTRICAL WIRING DIAGRAM FOR LIGHT PACKAGE

(WGN66a)

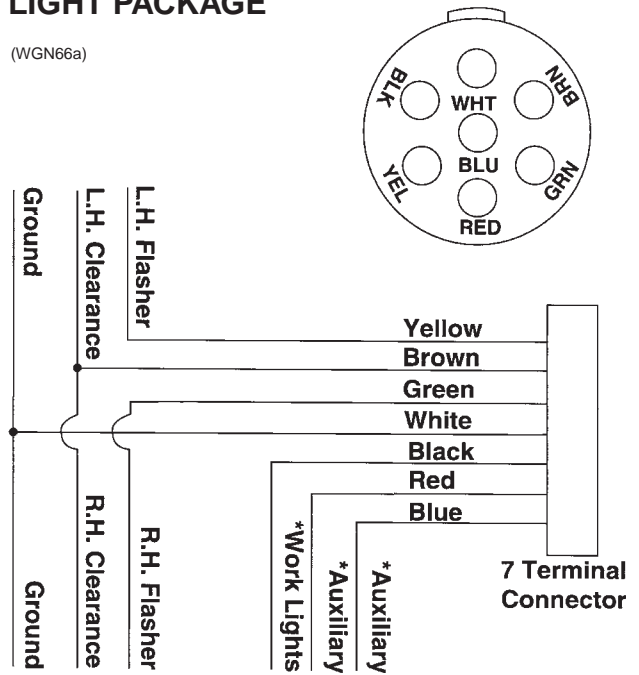

***Optional lights and wires (to be supplied by customer) may be wired into existing plug terminals.**

Light package supplied on the Model 2100 Stack Folding planter meets ASAE Standards. For the correct wiring harness to be wired into the lights on your tractor, check with the tractor manufacturer.

(PT50)

STYLE A Harness

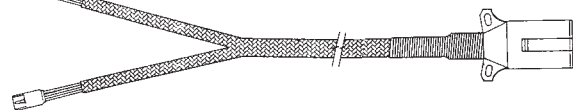

(ELC9)

STYLE B Harness

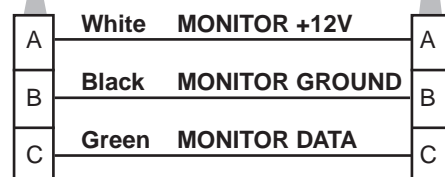
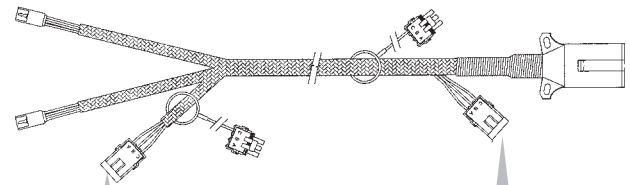

3 Pin Connector

3 Pin Connector

NOTE: These connectors not applicable to KM1000 or KM3000 monitor applications.

MAINTENANCE

ELECTRICAL WIRING DIAGRAMS FOR POINT ROW WRAP SPRING CLUTCHES

(EF10/ONS241/SFP6/ELC27)

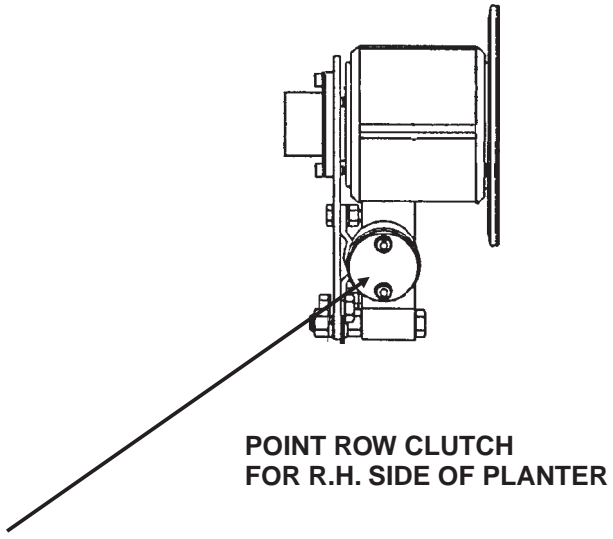
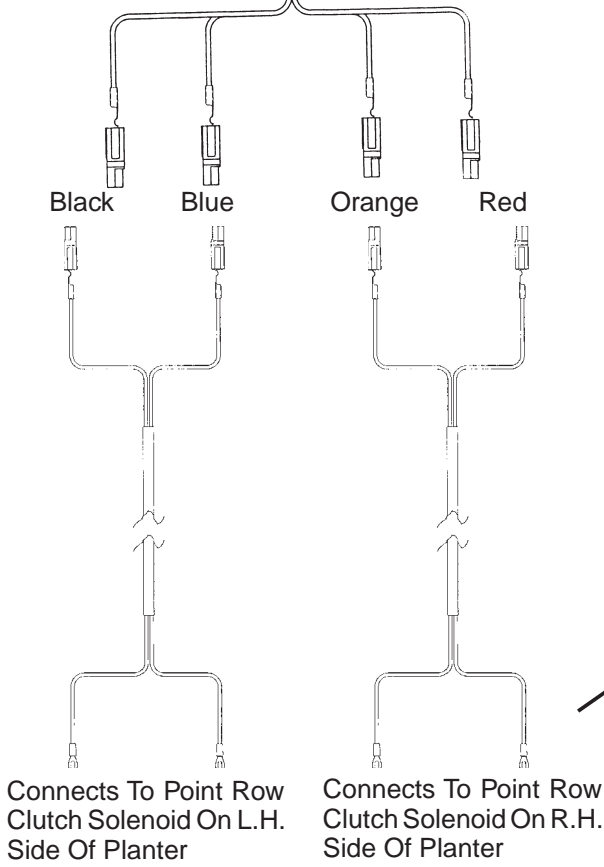
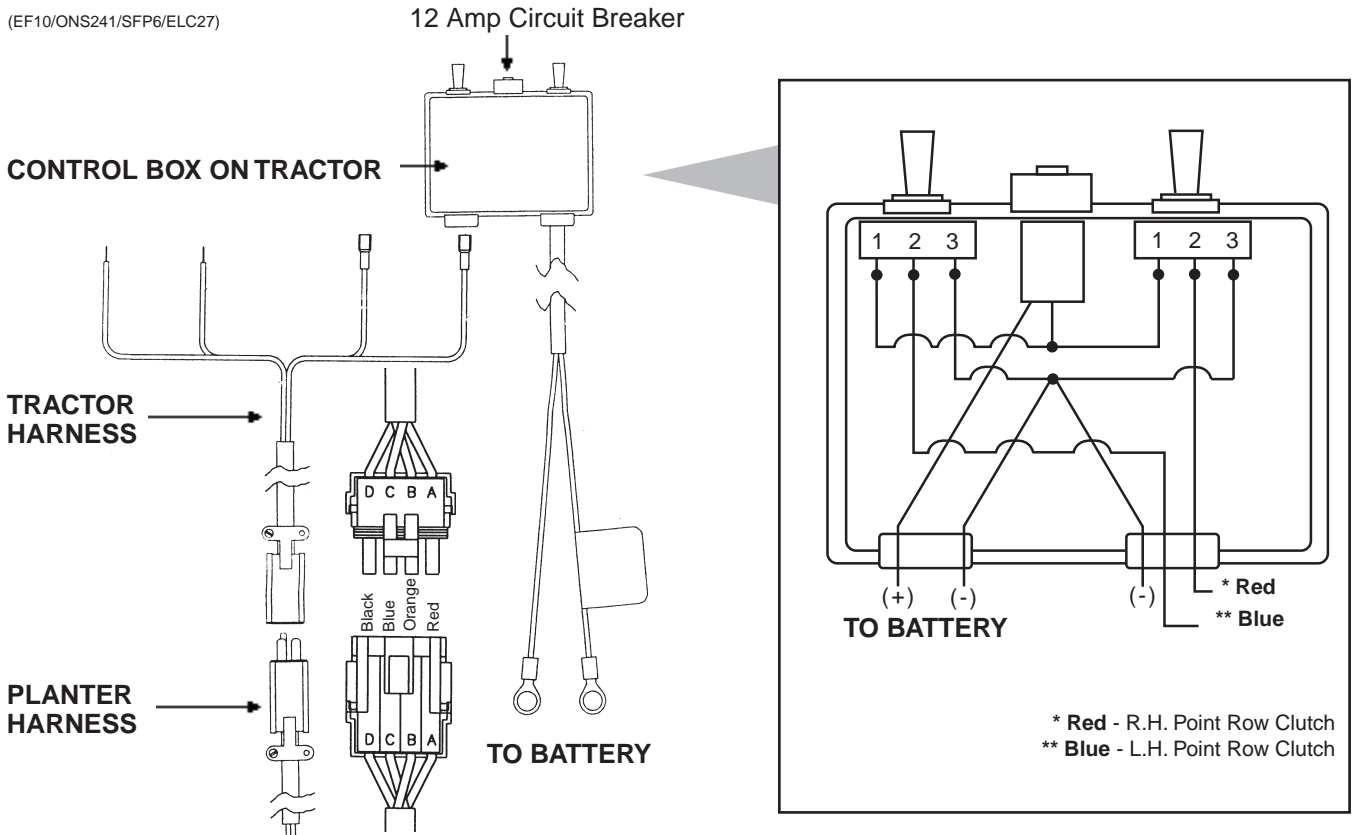

MAINTENANCE

ELECTRICAL WIRING DIAGRAMS FOR TWO-SPEED POINT ROW WRAP SPRING CLUTCHES

(SFP46/TWL71a/ELC27)

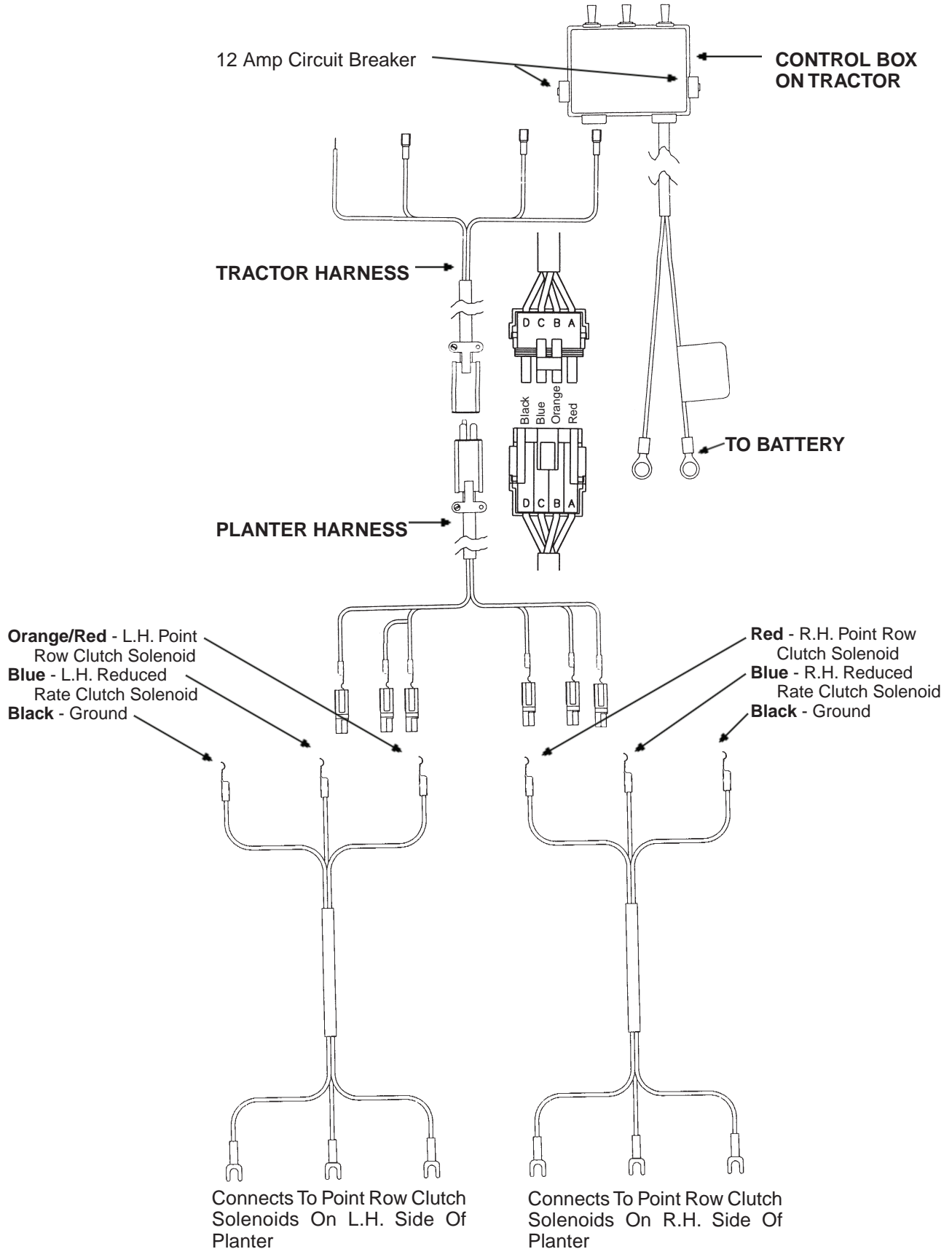

MAINTENANCE

(INS242)

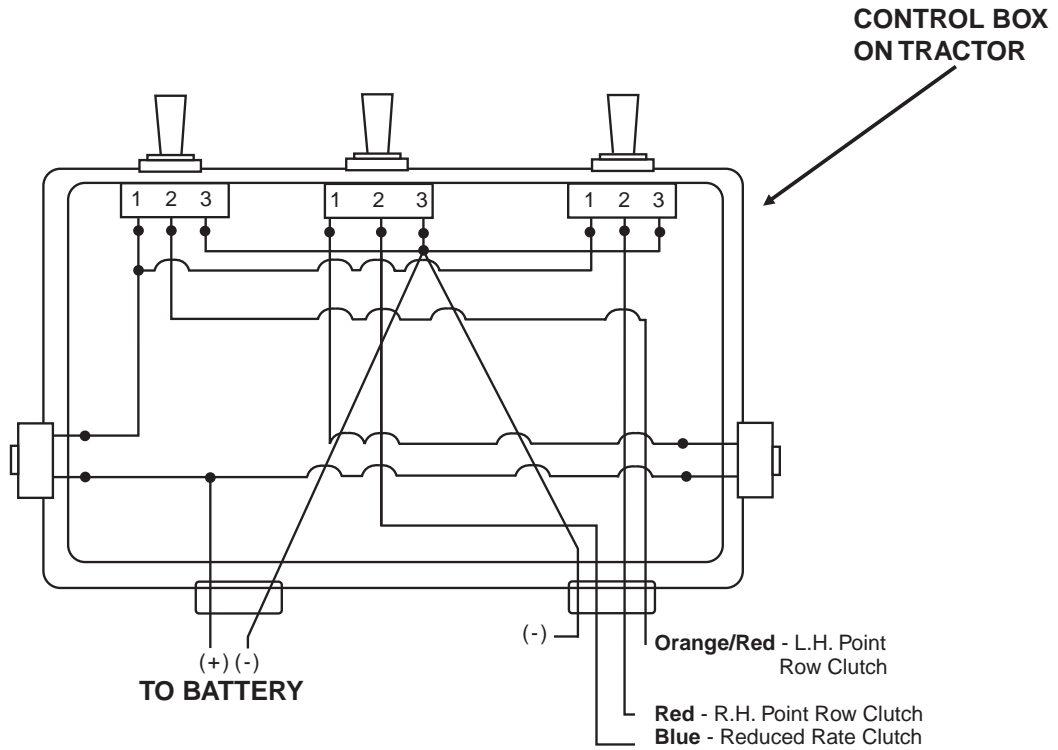

TWO-SPEED POINT ROW CLUTCH FOR L.H. SIDE OF PLANTER SHOWN

(INS126)

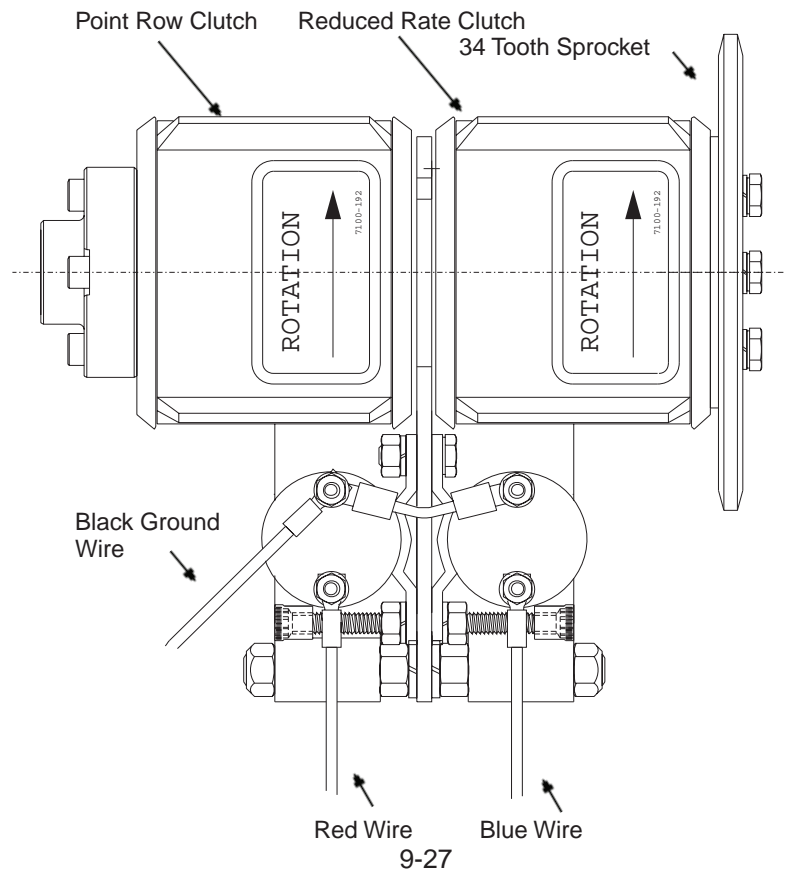

MAINTENANCE

HYDRAULIC SCHEMATIC - FOLD SYSTEM

(HYD1/HYD2/HYD16)

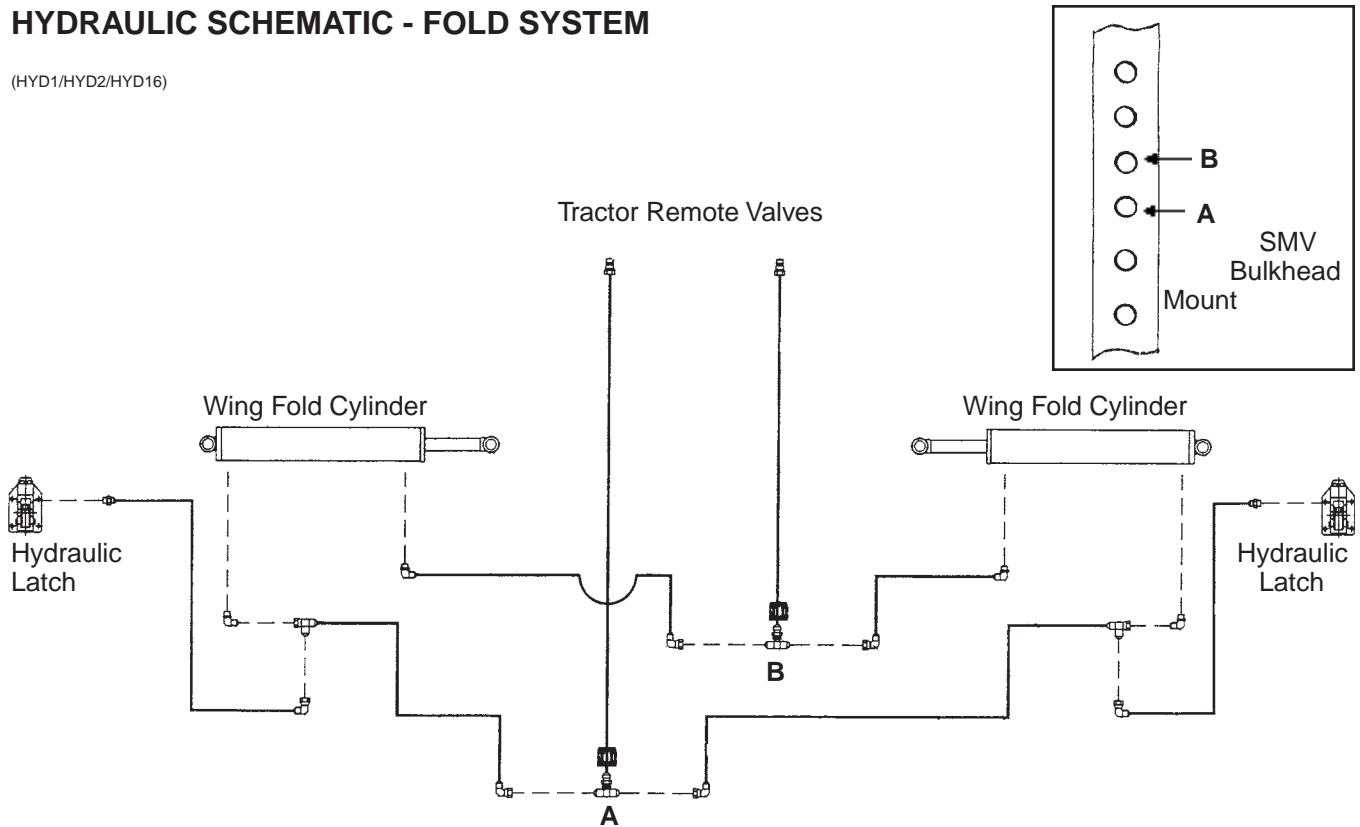

HYDRAULIC SCHEMATIC - MARKER SYSTEM

(HYD2-17)

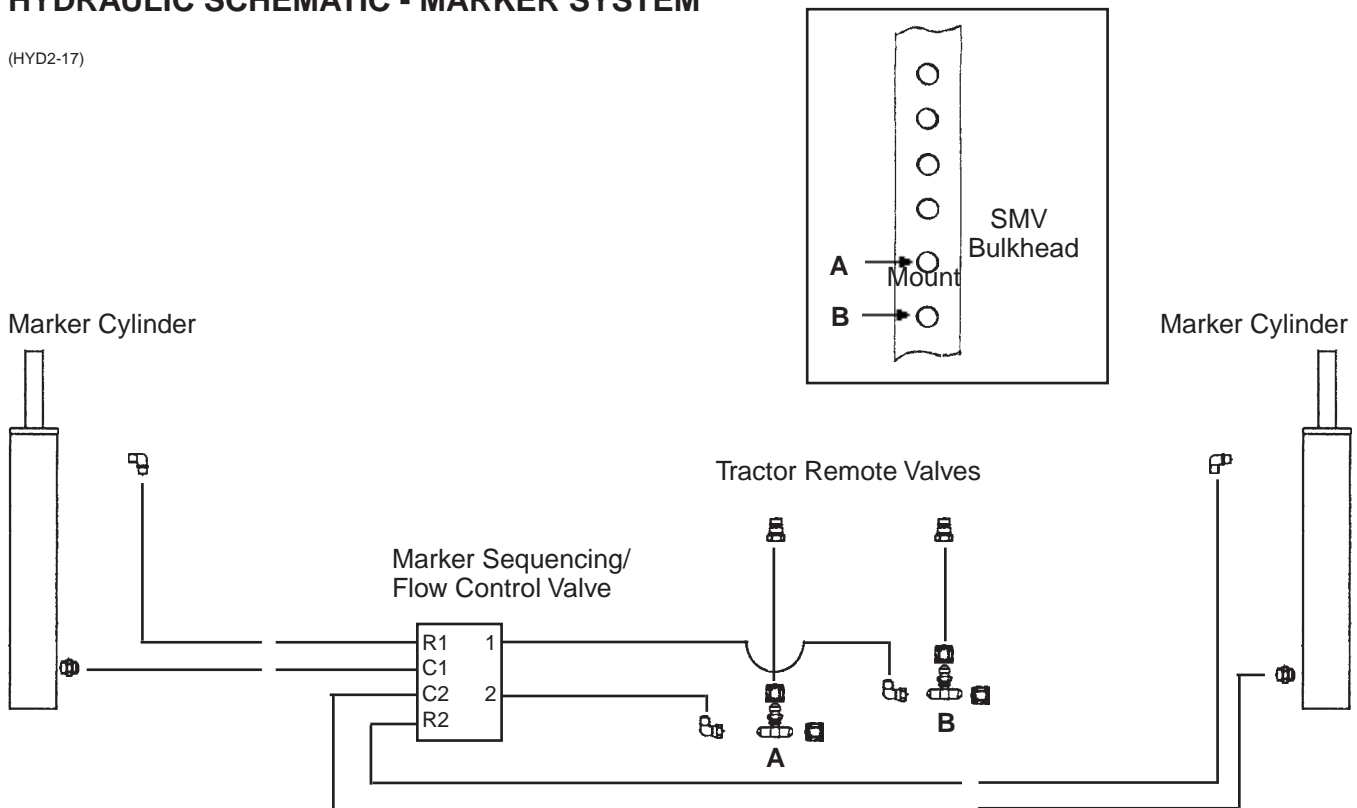

MAINTENANCE

HYDRAULIC SCHEMATIC - DUAL LIFT ASSIST WHEEL PACKAGE

(HYD2-17)

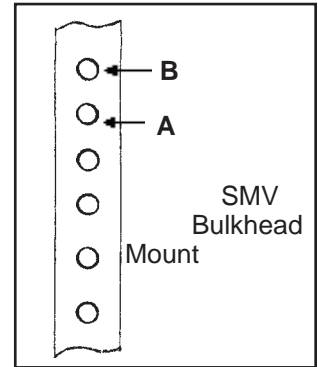

Dual Lift Assist Cylinder

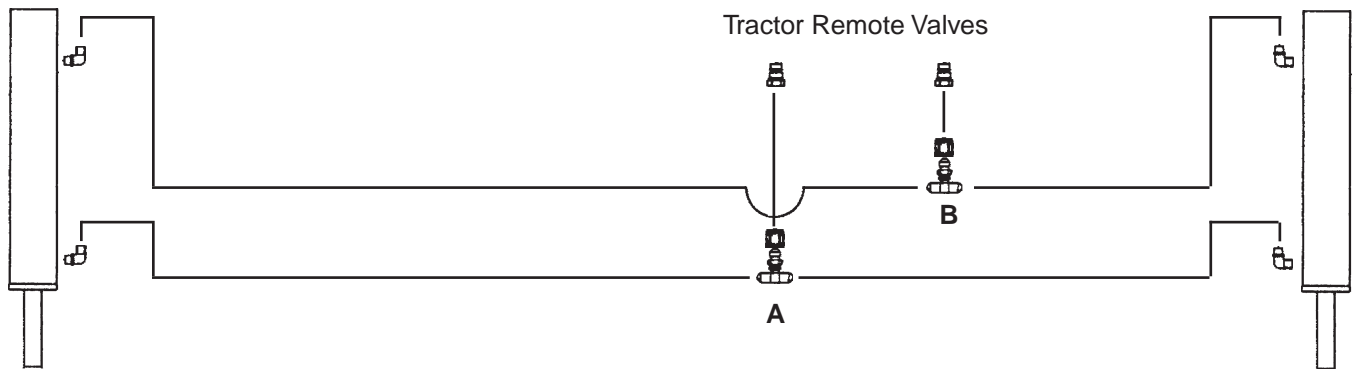

Dual Lift Assist Cylinder

HYDRAULIC SCHEMATIC - DUAL LIFT ASSIST WHEEL PACKAGE (Plumbed Into 3 Point Circuit)

(HYD2-17)

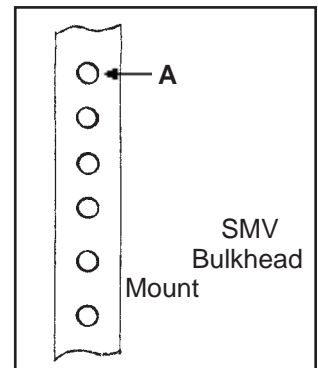

Dual Lift Assist Cylinder

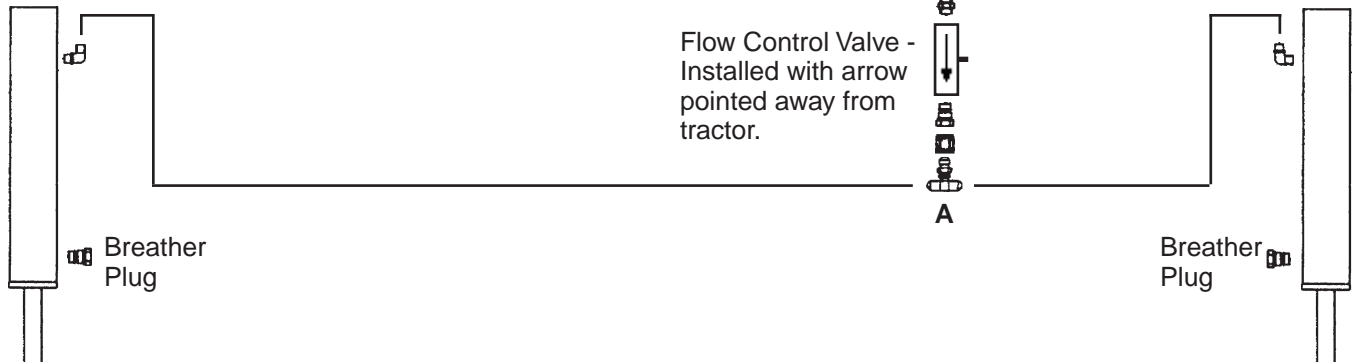

Dual Lift Assist Cylinder

MAINTENANCE

HYDRAULIC SCHEMATIC - WING DOWN FLEX CYLINDER PACKAGE

(HYD2-17)

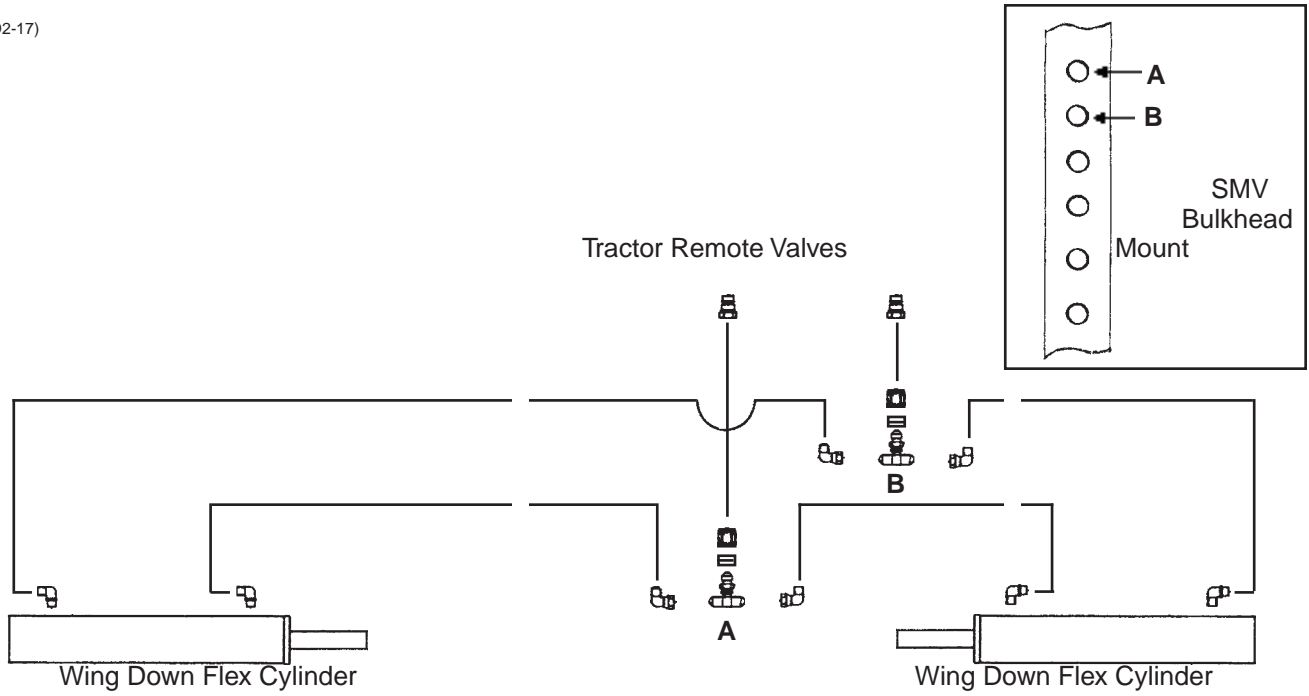

HYDRAULIC SCHEMATIC - WING DOWN FLEX CYLINDER PACKAGE AND DUAL LIFT ASSIST WHEEL PACKAGE

(HYD2-17)

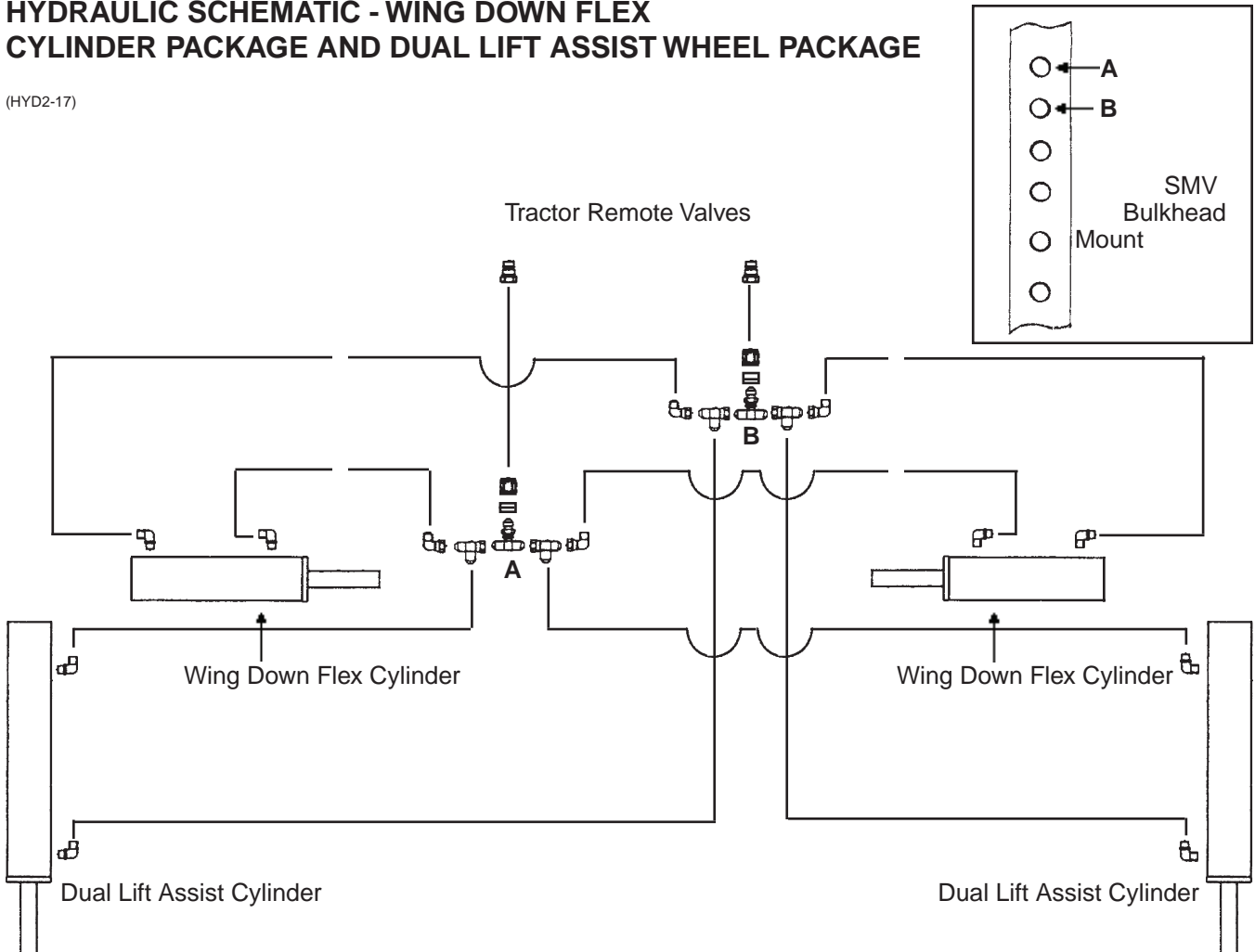

PARTS LIST INDEX

ROW UNIT

Bed Leveler, Row Unit Mounted	P20
Brush-Type Seed Meter	P13
Covering Discs/Single Press Wheel	P6
Disc Furrower, Row Unit Mounted	P21
Finger Pickup Seed Meter	P12
Frame Mounted Coulter W/Disc Furrower	P24
Gauge Wheel	P5
Granular Chemical Banders	P14
Granular Chemical Hopper With Meter(s) & Throwout	P16
Granular Chemical Sub-Assemblies And Kits.....	P15
Hopper Support And Meter Drive	P10
No Till Coulter, Row Unit Mounted.....	P19
Parallel Arms, Mounting Support Plate And Quick Adjustable Down Force Springs	P4
Residue Wheel, Row Unit Mounted	P22
Residue Wheels, Coulter Mounted	P23
Seed Firming Wheel	P9
Seed Hopper.....	P11
Shank Assembly	P2
Spring Tooth Incorporator	P18
"V" Closing Wheels	P8

BASE MACHINE

Center Drop Assembly And Driveline	P52
Center Frame Assembly	P26
Center Section Gauge Wheel	P34
Contact Drive Wheel Assembly	P32
Cylinders.....	P67
Dual Lift Assist Wheels	P36
Electrical Components.....	P76
Flow Control Valve	P66
Ground Drive Wheel Assembly.....	P30
Hydraulic Systems	P59
Marker Assemblies	P54
Marker Sequencing/Flow Control Valve And Mount.....	P65
Marker Spindle/Hub/Blade.....	P58
Module Drive.....	P40
Point Row Wrap Spring Clutch	P42
Point Row Wrap Spring Clutch Electrical Components.....	P44
Transmission And Module Drive Assembly.....	P38
Two-Speed Point Row Wrap Spring Clutch.....	P46
Two-Speed Point Row Wrap Spring Clutch Electrical Components.....	P48
Two-Speed Point Row Wrap Spring Clutch Transmission And Module Drive	P50
Wing Assembly	P28
Wing Down Flex Cylinder Package	P33

ELECTRONIC SEED MONITOR

Electronic Seed Monitor (KM1000/KM3000)	P72
Electronic Seed Monitor (KPM I/KPM II).....	See Assembly Instruction IS364

Decals, Reflectors And Tie Straps	P74
---	-----

Numerical Index.....	a
----------------------	---

SHANK ASSEMBLY

RUB006/RUA044(RU1d/RU1c)

STYLE A

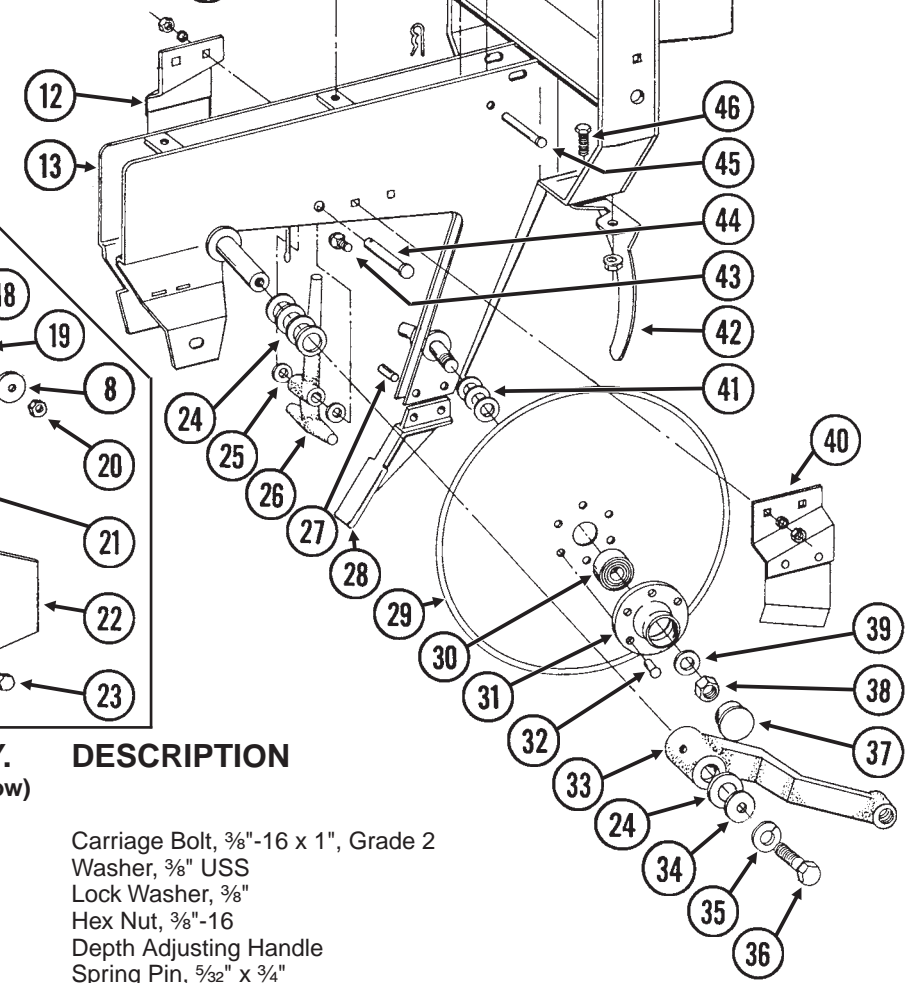
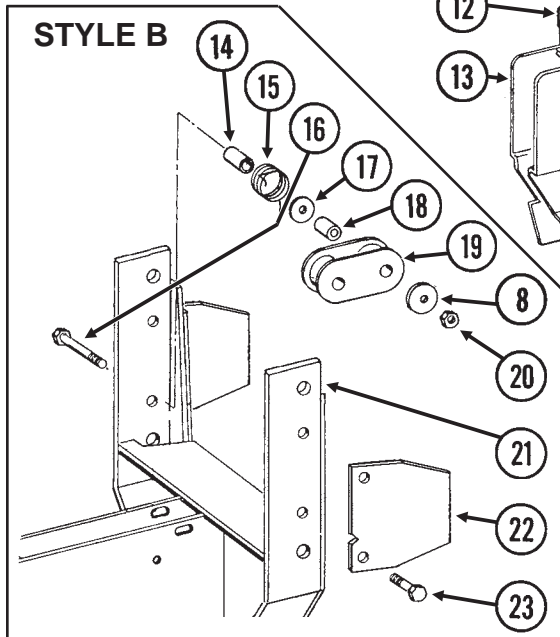
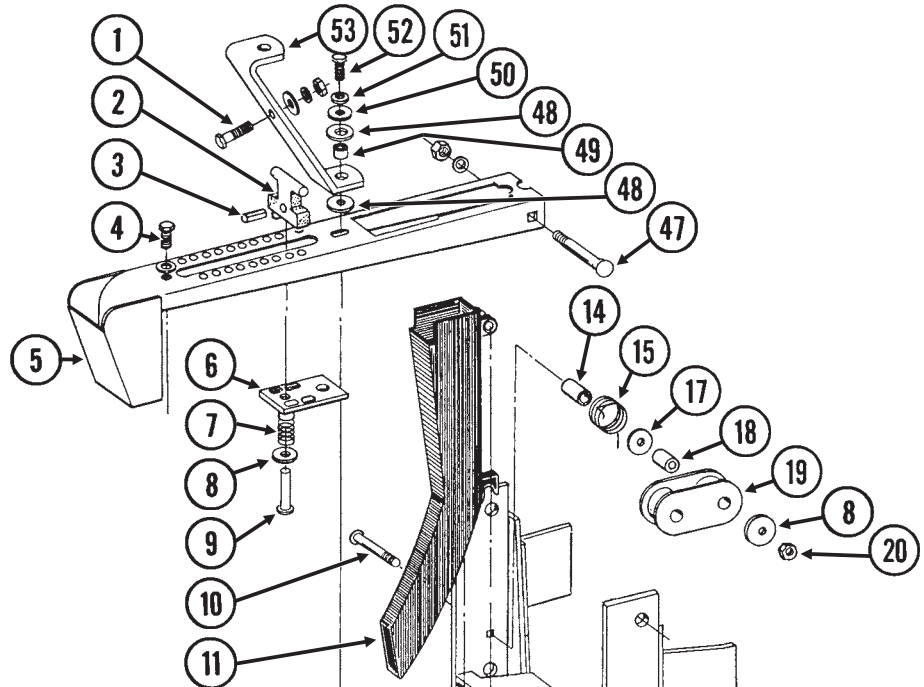

ITEM	PART NO.	QTY. (Per Row)	DESCRIPTION
------	----------	-------------------	-------------

1.	G10305	2	Carriage Bolt, 3/8"-16 x 1", Grade 2
	G10210	2	Washer, 3/8" USS
	G10229	2	Lock Washer, 3/8"
	G10101	2	Hex Nut, 3/8"-16
2.	GB0102	1	Depth Adjusting Handle
3.	G10605	1	Spring Pin, 5/32" x 3/4"
4.	G10001	1	Hex Head Cap Screw, 3/8"-16 x 1"
	G10229	1	Lock Washer, 3/8"
5.	GA0811	1	Shank Cover
6.	GB0105	1	Depth Adjusting Slide
7.	GD1066	1	Compression Spring
8.	G10210	1	Washer, 3/8" USS

SHANK ASSEMBLY

ITEM	PART NO.	QTY. (Per Row)	DESCRIPTION
9.	G10552	1	Clevis Pin, 3/8" x 2"
10.	G10307	1	Carriage Bolt, 3/8"-16 x 3 1/2", Grade 2
11.	GD1130	-	Seed Tube, Regular
	GA5880	-	Seed Tube W/High Rate Sensor
	GR1062	-	Seed Tube (With Holes For High Rate Sensor Installation)
	GR1087	-	Sensor Only (For GA5880)
	GR0676	-	Sunshade
	GD2117	-	Tie Strap, 14 1/2"
12.	GA2012L	1	Disc Scraper, L.H.
13.	GA0860	1	Shank (Sub G1K272)
14.	GD7318	1	Bushing, 1"
15.	GD1065	1	Idler Spring
16.	G10326	1	Hex Head Cap Screw, 3/8"-16 x 3 3/4"
17.	G10201	1	Special Washer
18.	GD1026	1	Spacer, 1 3/16"
19.	GD9240	1	Idler
20.	G10108	1	Lock Nut, 3/8"-16
21.	GA1306	1	Shank
22.	GD10867	2	Stop
23.	G10004	3	Hex Head Cap Screw, 3/8"-16 x 1 1/4"
	G10229	3	Lock Washer, 3/8"
	G10101	3	Hex Nut, 3/8"-16
24.	G10526	-	Spacer Washer, .048" Gauge (As Required)
25.	G10206	2	Washer, 1/2" SAE
26.	GB0104	1	Depth Adjusting Stop
27.	G10814	2	Spring Pin, 1/4" x 7/8"
28.	GB0103	1	Seed Tube Guard/Inner Scraper
29.	GD1030	2	Disc, 15"
30.	GA2014	2	Bearing
31.	GD10473	2	Housing
32.	G10427	12	Rivet, 1/4" x 1/2"
33.		-	See "Gauge Wheel", Page P5
34.	G10216	2	Washer, 1/2" USS
35.	G10228	2	Lock Washer, 1/2"
36.	G10014	2	Hex Head Cap Screw, 1/2"-13 x 1"
37.	GD6533	2	Dust Cap
38.	G10503	1	Jam Nut, 5/8"-11, R.H.
	G10504	1	Jam Nut, 5/8"-11, L.H.
39.	G10204	2	Machine Bushing, 21/32"
40.	GA2012R	1	Disc Scraper, R.H.
41.	G10213	-	Machine Bushing, .030" Gauge (As Required)
42.	GD1033	1	Shield
43.	G10328	4	Hex Head Cap Screw, 3/8"-16 x 5/8"
	G10622	4	Flange Nut, 3/8"-16
44.	G10555	1	Clevis Pin, 1/2" x 2 1/2"
	G10451	1	Cotter Pin, 1/8" x 1"
45.	G10551	1	Clevis Pin, 1/4" x 2 1/2"
	G10669	1	Hair Pin Clip, No. 22
46.	G10312	2	Carriage Bolt, 5/16"-18 x 3/4", Grade 2
	G10620	2	Flange Nut, 5/16"-18
47.	G10304	1	Carriage Bolt, 3/8"-16 x 3", Grade 2
	G10108	1	Lock Nut, 3/8"-16
48.	GD1120	2	Rubber Washer
49.	GD1110	1	Bushing, 1/2"
50.	G10208	1	Special Washer, 13/32"
51.	G10229	1	Lock Washer, 3/8"
52.	G10003	1	Hex Head Cap Screw, 3/8"-16 x 1 1/2"
53.	GD1027	1	Stabilizer Bracket
A.	GA2013	-	Disc And Bearing Assembly, Less Bearing Cap (Items 29-32)
B.	G1K212	-	Meter Drive Idler Kit (Items 8 And 14-20)
C.	G1K272	-	Row Unit Shank Replacement Kit (Items 16 And 20-23)

PARALLEL ARMS, MOUNTING SUPPORT PLATE AND QUICK ADJUSTABLE DOWN FORCE SPRINGS

RUB007/RUB015/RUB016/RUB013/RUB019/RUA048(RU2a/RU3/RU35a)

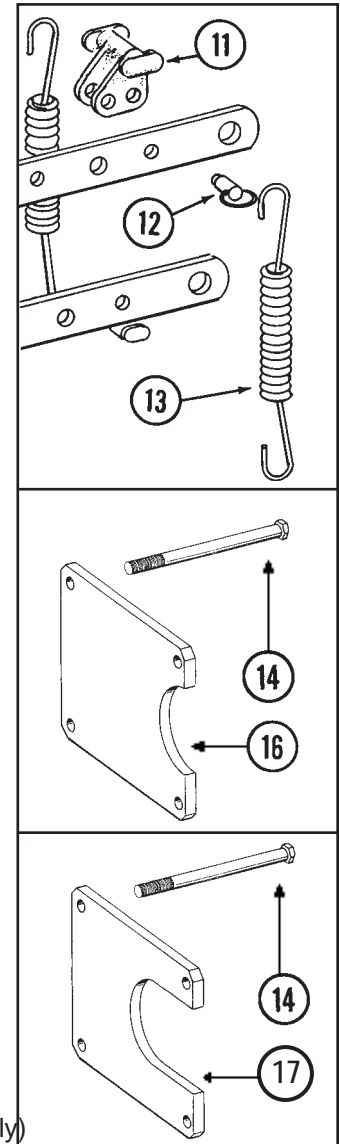
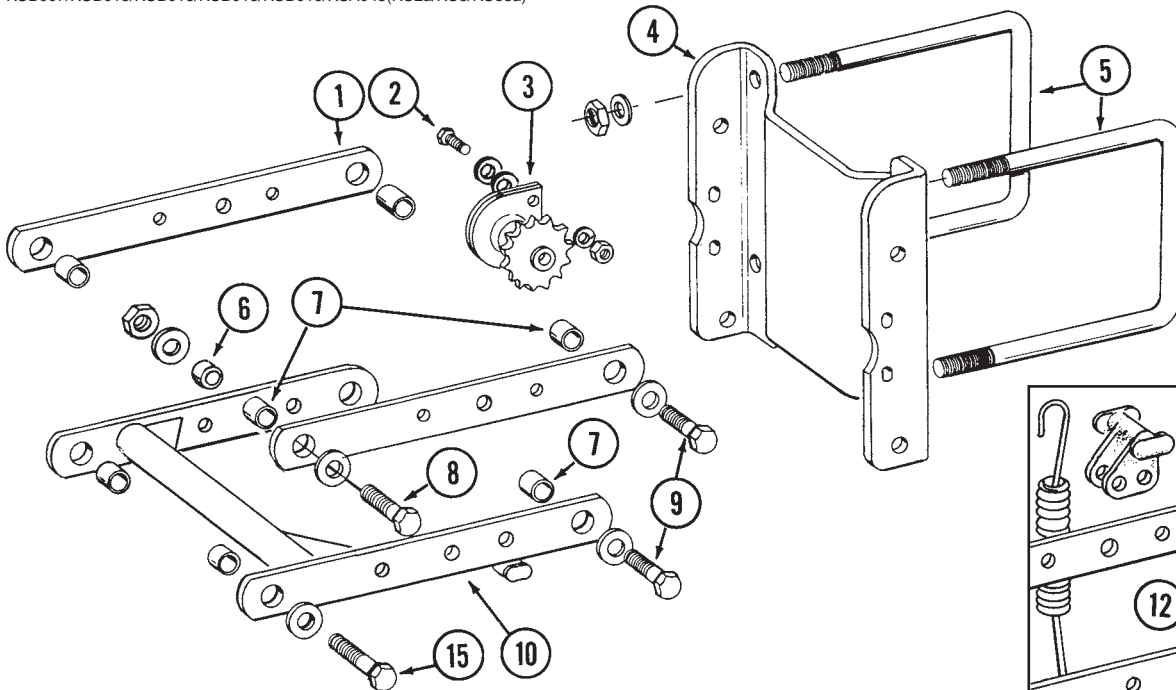

ITEM	PART NO.	QTY. (Per Row)	DESCRIPTION
1.	GD7619	2	Upper Parallel Arm
2.	G10004	2	Hex Head Cap Screw, 3/8"-16 x 1 1/4"
	G10210	-	Washer, 3/8" USS (As Required)
	G10229	2	Lock Washer, 3/8"
	G10101	2	Hex Nut, 3/8"-16
3.	GA1720	1	Bearing/Sprocket, 7/8" Bore
4.	GD10036	1	Mounting Support Plate
5.	GD1114	2	U-Bolt, 7" x 7" x 5/8"-11
	G10230	4	Lock Washer, 5/8"
	G10104	4	Hex Nut, 5/8"-11
6.	GD1109	2	Pivot Bushing, 1/4"
7.	GB0218	8	Bushing, 19/32"
8.	G10752	2	Hex Head Cap Screw, 5/8"-18 x 2 1/4"
	GD7805	4	Special Washer
	G10412	2	Lock Nut, 5/8"-18
9.	G10732	4	Hex Head Cap Screw, 5/8"-18 x 2"
	GD7805	4	Special Washer
	G10412	4	Lock Nut, 5/8"-18
10.	GA5651	1	Lower Parallel Arm
11.	GB0186	2	Spring Anchor
12.	G10545	2	Detent Pin, 1" Grip
13.	GD8249	-	Spring
14.	G10152	4	Hex Head Cap Screw, 5/8"-11 x 9" (16 Row Only)
	G10230	4	Lock Washer, 5/8"
	G10104	4	Hex Nut, 5/8"-11
15.	G10751	2	Hex Head Cap Screw, 5/8"-18 x 1 3/4"
	GD7805	2	Special Washer
	G10412	2	Lock Nut, 5/8"-18
16.	GD10575	1	Backing Plate (16 Row Only)
17.	GD10753	1	Backing Plate (12 Row 36"- 38" If Applicable)

GAUGE WHEEL

RUB001/RUB018/RUA039/RUB018/RUA044(RU5a/RU6/RU7)

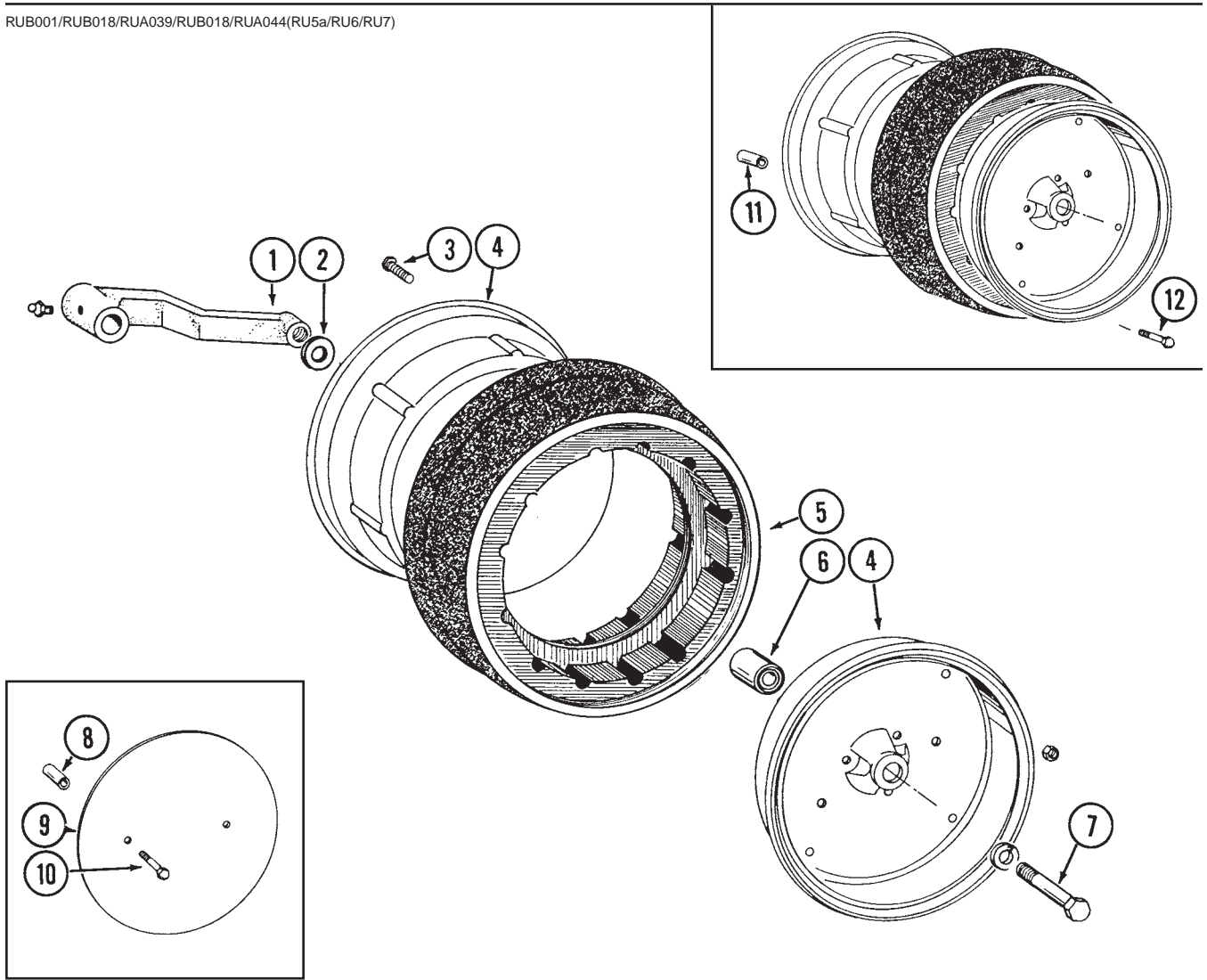

ITEM	PART NO.	QTY. (Per Row)	DESCRIPTION
1.	GA6614	2	Wheel Arm With Grease Fitting
	G10640	2	Grease Fitting, 1/4"-28
2.	G10204	1	Machine Bushing, 2 1/32"
3.	G10018	14	Hex Head Cap Screw, 5/16"-18 x 5/8"
	G10109	14	Lock Nut, 5/16"-18
4.	GD1048	4	Half Wheel
5.	GD1086	2	Tire
6.	GA6171	2	Bearing
7.	G10010	2	Hex Head Cap Screw, 5/8"-11 x 3"
	G10230	2	Lock Washer, 5/8"
8.	GD0973	4	Wheel Cover Sleeve, 1 1/2" (Optional)
9.	GD1353	2	Wheel Cover (Optional)
10.	G10069	4	Hex Head Cap Screw, 5/16"-18 x 2 1/4"
	G10232	4	Lock Washer, 5/16"
	G10106	4	Hex Nut, 5/16"-18
11.	GD8811	8	Dual Gauge Wheel Sleeve, 4 1/8" (Optional)
12.	G10764	8	Hex Head Cap Screw, 5/16"-18 x 5"
	G10109	8	Lock Nut, 5/16"-18
A.	GA6615	-	Gauge Wheel Complete (Items 3-6)

COVERING DISCS/SINGLE PRESS WHEEL

RUA042/RUA044(RU8)

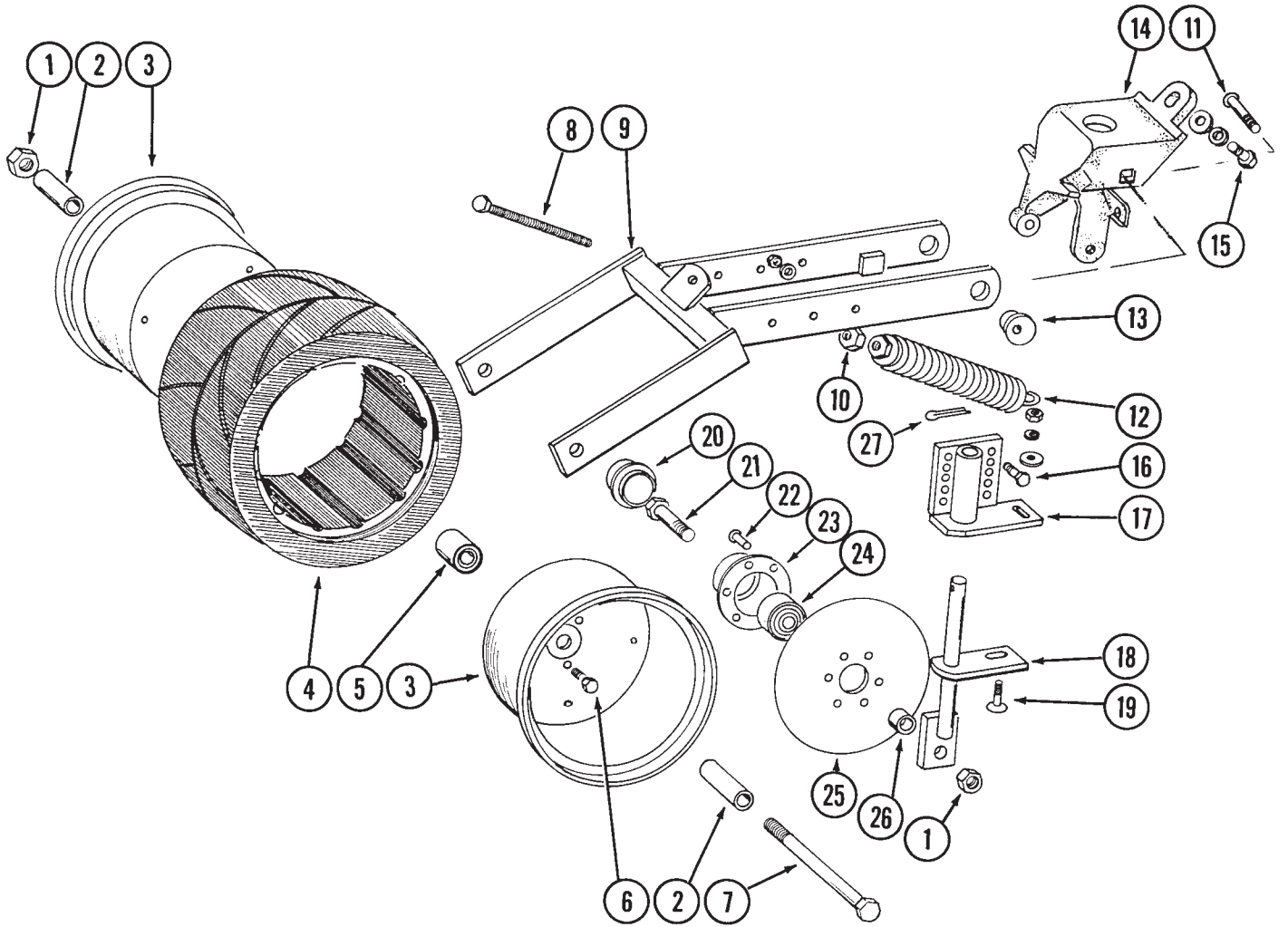

COVERING DISCS/SINGLE PRESS WHEEL

ITEM	PART NO.	QTY. (Per Row)	DESCRIPTION
1.	G10107	3	Lock Nut, 5/8"-11
2.	GD3181-12	2	Spacer, 2 7/8"
3.	GD9562	2	Half Wheel
4.	GD9305	1	Tire
5.	GA6171	1	Bearing
6.	G10018	7	Hex Head Cap Screw, 5/16"-18 x 5/8"
	G10109	7	Lock Nut, 5/16"-18
7.	G10152	1	Hex Head Cap Screw, 5/8"-11 x 9"
8.	G10015	1	Adjusting Bolt, 1/2"-13 x 5"
9.	GA6619	1	Mounting Arm
10.	G10102	1	Hex Nut, 1/2"-13
11.	G10801	2	Carriage Bolt, 1/2"-13 x 2 1/4"
	G10315	-	Carriage Bolt, 1/2"-13 x 1 1/2"
	G10216	2	Washer, 1/2" USS
	G10102	2	Hex Nut, 1/2"-13
12.	GA2054	1	Spring
13.	GB0239	2	Eccentric Bushing
14.	GB0233	1	Wheel Arm Stop
15.	G10003	1	Hex Head Cap Screw, 3/8"-16 x 1 1/2"
	G10229	1	Lock Washer, 3/8"
	G10210	2	Washer, 3/8" USS
16.	G10171	4	Hex Head Cap Screw, 5/16"-18 x 1 1/4"
	G10232	4	Lock Washer, 5/16"
	G10106	4	Hex Nut, 5/16"-18
17.	GA6620	2	Bracket
18.	GA6618	2	Mount
19.	G10303	2	Carriage Bolt, 5/16"-18 x 1"
	G10219	2	Washer, 5/16" USS
	G10232	2	Lock Washer, 5/16"
	G10106	2	Hex Nut, 5/16"-18
20.	GD6533	2	Cap
21.	G10006	2	Hex Head Cap Screw, 5/8"-11 x 2 1/4"
22.	G10427	12	Rivet, 1/4" x 1/2"
23.	GD10473	2	Bearing Housing
24.	GA2014	2	Bearing
25.	GD9290	2	Blade, 8" Diameter
26.	GD1109	2	Spacer, 1/4"
27.	G10463	2	Cotter Pin, 1/4" x 1 1/2"
A.	GA6733	-	Single Press Wheel Complete With Bearing (Items 3-6)
B.	GA6801	-	Covering Disc Complete With Bearing (Items 22-25)

"V" CLOSING WHEELS

RUB004/RUA044/RUA046(RU9)

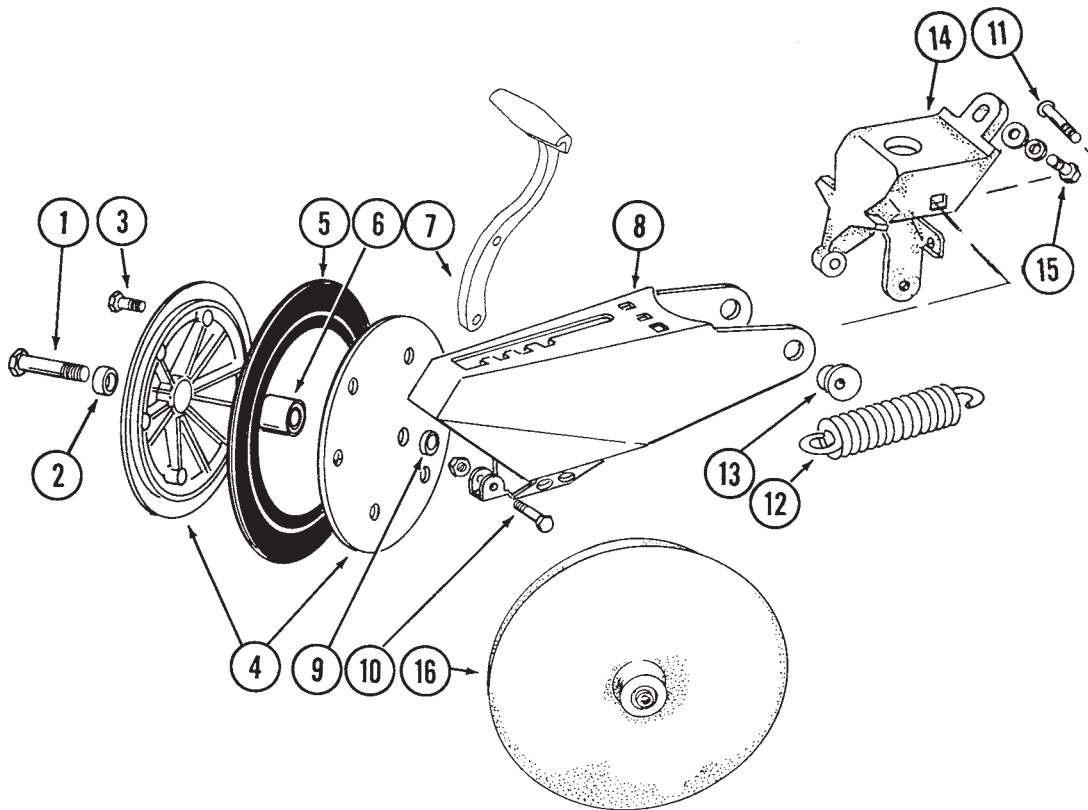

ITEM	PART NO.	QTY. (Per Row)	DESCRIPTION
1.	G10013	2	Hex Head Cap Screw, 5/8"-11 x 3 1/2"
	G10107	2	Lock Nut, 5/8"-11
2.	GB0218	2	Bushing, 19/32"
3.	G10064	6	Hex Head Cap Screw, 1/4"-20 x 1"
	G10103	6	Hex Nut, 1/4"-20
4.	GD9120	4	Nylon Half Wheel
5.	GD1085	2	Rubber Tire, 1" x 12"
6.	GA6171	2	Bearing
7.	GB0254	1	Lever
8.	GA6613	1	Arm
9.	GD1109	2	Bushing, 1/4"
10.	G10133	1	Hex Head Cap Screw, 5/16"-18 x 1 1/2"
	G10109	1	Lock Nut, 5/16"-18
11.	G10747	2	Carriage Bolt, 1/2"-13 x 2"
	G10111	2	Lock Nut, 1/2"-13
12.	GD8460	1	Spring
13.	GB0219	2	Eccentric Bushing
14.	GB0233	1	Wheel Arm Stop
15.	G10003	1	Hex Head Cap Screw, 3/8"-16 x 1 1/2"
	G10229	1	Lock Washer, 3/8"
	G10210	2	Washer, 3/8" USS
16.	GA6597	-	Cast Iron Closing Wheel W/Bearing
	GA6171	-	Bearing
A.	GA6434	-	Rubber Closing Wheel Complete With Bearing (Items 3-6)

SEED FIRING WHEEL

RUB006/RJA044(RU10b)

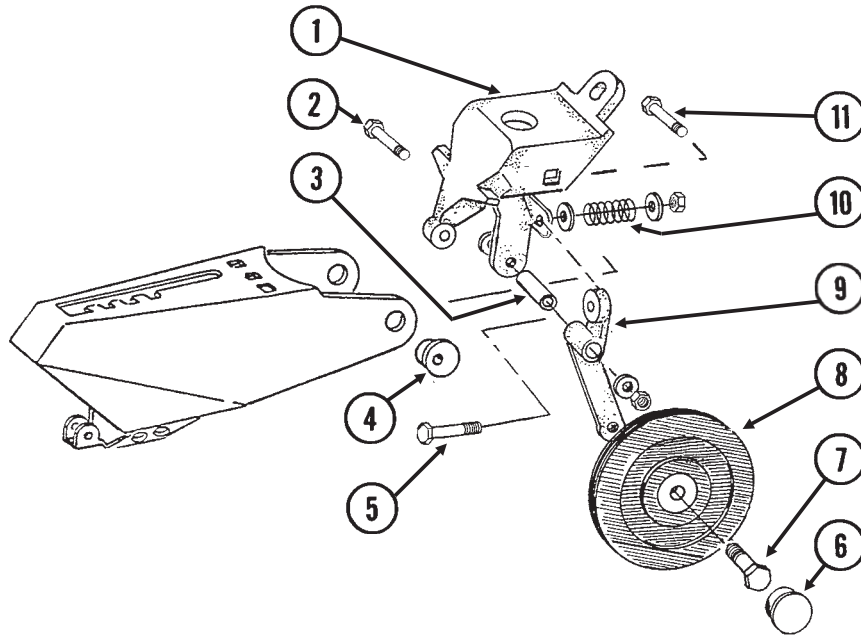

ITEM	PART NO.	QTY. (Per Row)	DESCRIPTION
1.	GB0233	1	Wheel Arm Stop
2.	G10049	1	Hex Head Cap Screw, 3/8"-16 x 2 1/2"
	G10210	2	Washer, 3/8" USS
	G10108	1	Lock Nut, 3/8"-16
3.	GD9786	1	Bushing
4.	GB0219	2	Eccentric Bushing
5.	G10062	1	Hex Head Cap Screw, 3/8"-16 x 3"
	G10210	2	Washer, 3/8" USS
	G10108	1	Lock Nut, 3/8"-16
6.	GD1079	1	Dust Cap
7.	G10055	1	Hex Head Cap Screw, 5/8"-11 x 1 1/4"
8.	GA7580	1	Seed Firming Wheel W/Bearing And Snap Ring
	GA2014	-	Bearing
	G10770	-	Snap Ring, 1 11/16"
9.	GB0245	1	Arm
10.	GD9787	1	Spring
11.	G10747	2	Carriage Bolt, 1/2"-13 x 2"
	G10111	2	Lock Nut, 1/2"-13
A.	GA6937	-	Seed Firming Wheel Retrofit Package (Items 1-11)

HOPPER SUPPORT AND METER DRIVE

RUB005(RU11c)

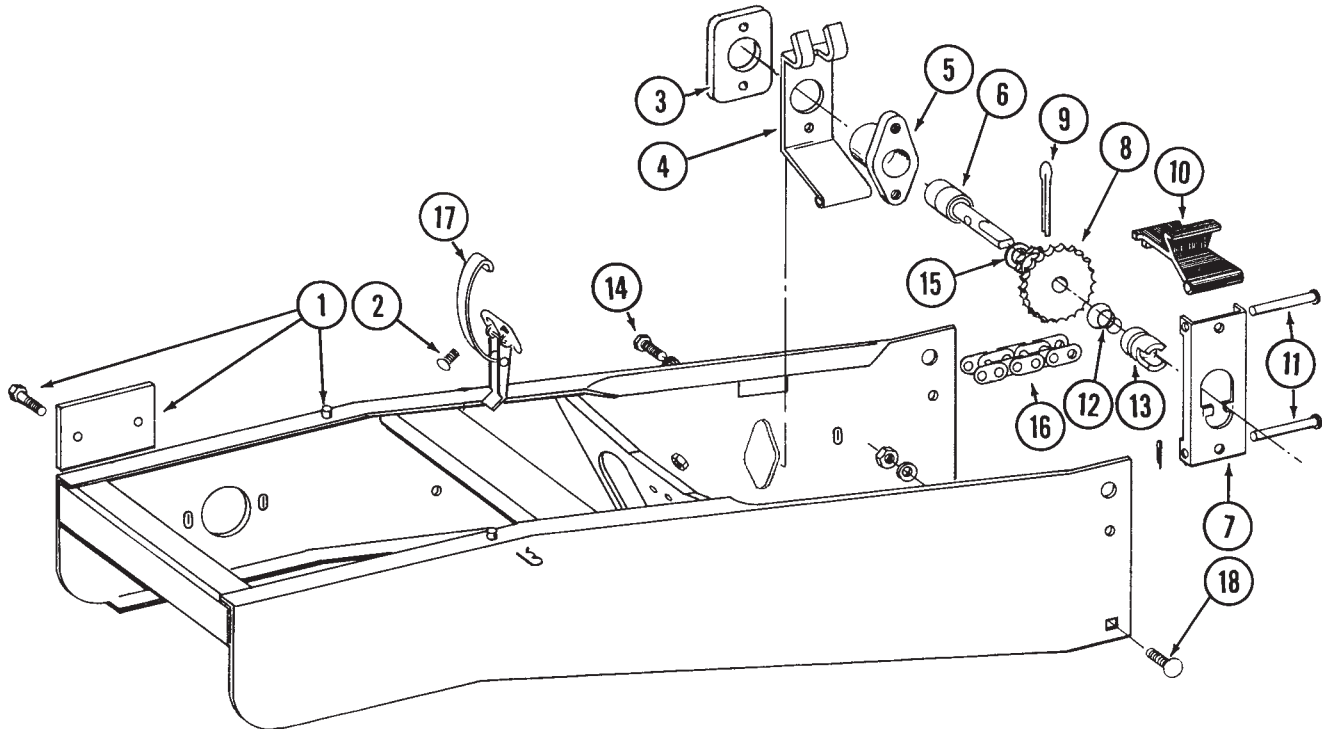

ITEM	PART NO.	QTY. (Per Row)	DESCRIPTION
1.	GR1066	1	Hopper Support W/Cover And Hardware
	GD7618	1	Cover
	G10312	2	Carriage Bolt, 5/16"-18 x 3/4"
	G10620	2	Flange Nut, 5/16"-18
2.	G10309	2	Carriage Bolt, 1/4"-20 x 5/8", Grade 2
	G10621	2	Flange Nut, 1/4"-20
3.	GD2128	1	Plate
4.	GD1037	1	Bearing Support
5.	GB0108	1	Bearing Housing
6.	GA2016	1	Bearing
7.	GD1036	1	Drive Release Lever
8.	GB0107	1	Sprocket, 11/19 Tooth
9.	G10457	1	Cotter Pin, 5/32" x 1 1/2"
10.	GD1035	1	Release Handle
11.	G10553	2	Clevis Pin, 1/4" x 2 5/8"
	G10455	2	Cotter Pin, 1/16" x 1/2"
12.	GD10464	1	Compression Spring
13.	GB0243	1	Drive Coupler
14.	G10019	2	Hex Head Cap Screw, 5/16"-18 x 1"
	G10232	2	Lock Washer, 5/16"
15.	G10204	-	Machinery Bushing, 2 1/32" (As Required)
16.	G3303-98	1	Roller Chain, No. 41, 98 Links Including Connector Link
	GR0196	1	Connector Link, No. 41
17.	GA2007	1	Hopper Hold Down Latch
18.	G10305	1	Carriage Bolt, 3/8"-16 x 1", Grade 2
	G10004	-	Hex Head Cap Screw, 3/8"-16 x 1 1/4"
	G10229	1	Lock Washer, 3/8"
	G10101	1	Hex Nut, 3/8"-16
A.	GA4822	-	Meter Drive Assembly Complete (Items 3-14)

SEED HOPPER

RUA015(RU12b)

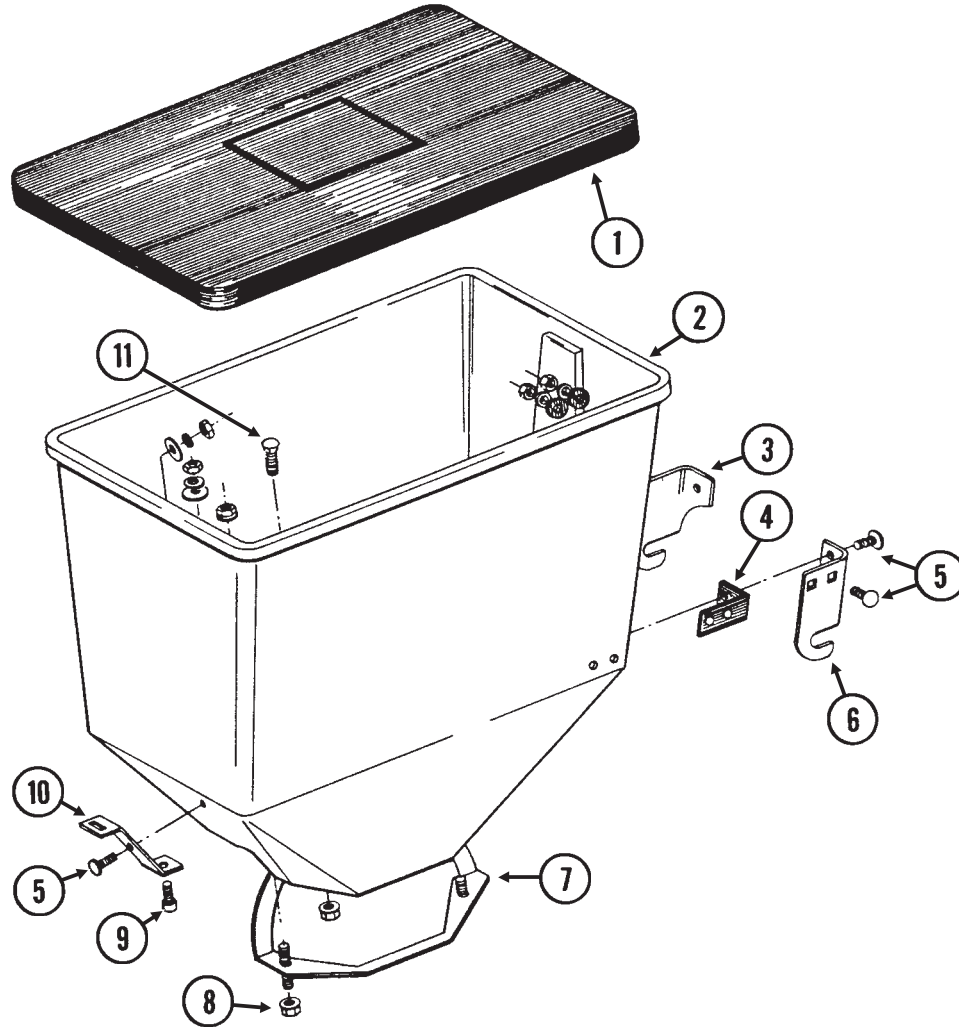

ITEM	PART NO.	QTY. (Per Row)	DESCRIPTION
1.	GA2327	1	Lid With Clip
2.	GD1053	1	Seed Hopper
3.	GD1051L	1	Bracket, Left Hand
4.	GD1054	2	Mounting Pad
5.	G10310	7	Carriage Bolt, 1/4"-20 x 3/4", Grade 2
	GD1121	7	Rubber Washer
	G10209	7	Washer, 1/4" USS
	G10110	7	Self Locking Nut, 1/4"-20
6.	GD1051R	1	Bracket, Right Hand
7.	GA2027	1	Retainer
8.	G10620	4	Flange Nut, 5/16"-18
9.	G10520	1	Hex Socket Head Cap Screw, 3/8"-16 x 3/4", Grade 8
	G10210	1	Washer, 3/8" USS
	G10229	1	Lock Washer, 3/8"
	G10101	1	Hex Nut, 3/8"-16
10.	GD1055	1	Clip
11.	G10310	1	Carriage Bolt, 1/4"-20 x 3/4", Grade 2
	G10621	1	Flange Nut, 1/4"-20
A.	GA2058	-	Seed Hopper With Hardware, Less Lid (Items 2-11)

FINGER PICKUP SEED METER

RUA015(RU13a/RU37b)

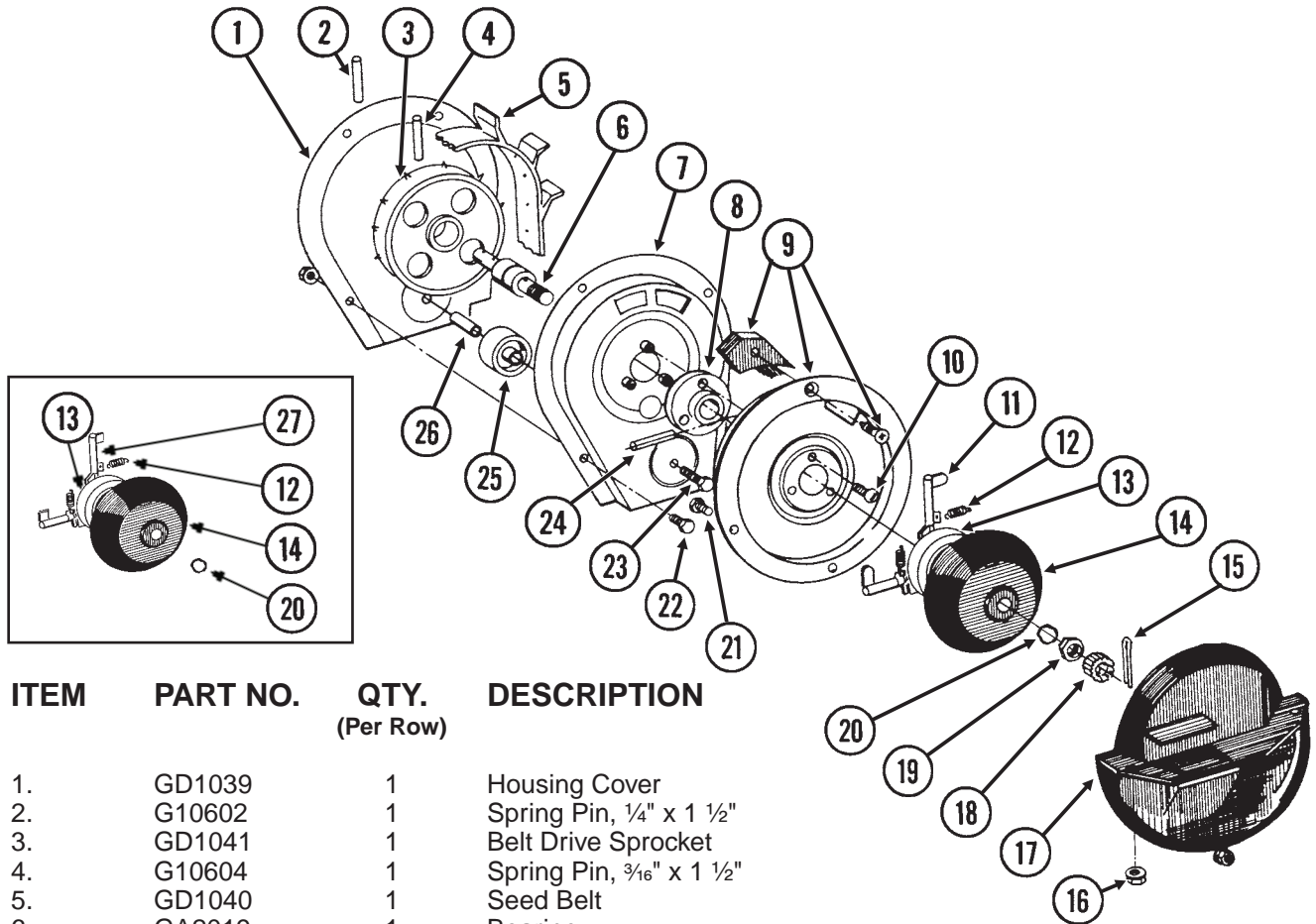

ITEM	PART NO.	QTY. (Per Row)	DESCRIPTION
1.	GD1039	1	Housing Cover
2.	G10602	1	Spring Pin, 1/4" x 1 1/2"
3.	GD1041	1	Belt Drive Sprocket
4.	G10604	1	Spring Pin, 3/16" x 1 1/2"
5.	GD1040	1	Seed Belt
6.	GA2019	1	Bearing
7.	GA2018	1	Conveyor Housing
8.	GB0110	1	Bearing Housing
9.	GR0664	1	Carrier With Brush And Screw
	GA2020	-	Brush
	G10690	-	Rolling Thread Screw, No. 10 x 3/4"
10.	G10401	3	Slotted Hex Washer Head Screw, No. 10-32 x 5/8"
11.	GD10733	12	Finger, Corn
12.	GD6501	12	Spring
13.	GB0111	1	Cam
14.	GD1045	1	Finger Holder
15.	G10470	1	Cotter Pin, 5/32" x 1"
16.	G10620	2	Flange Nut, 5/16"-18
17.	GD1046	1	Seed Baffle
18.	GD1083	1	Cover Nut, 5/8"-18
19.	G10500	1	Jam Nut, 5/8"-18 UNF
20.	GA8343	1	Wave Washer, 5/8" (Triple Wave)
21.	G10020	3	Hex Head Cap Screw, 1/4"-20 x 5/8"
	G10323	3	Hex Flange Nut, 1/4"-20
22.	G10022	4	Hex Head Cap Screw, 1/4"-20 x 1/2"
	G10621	4	Flange Nut, 1/4"-20
23.	G10021	1	Hex Head Cap Screw, 1/4"-20 x 1 1/2"
	G10621	1	Flange Nut, 1/4"-20
24.	G10603	1	Spring Pin, 1/4" x 1 1/4"
25.	GD1042	1	Idler
26.	GB0120	1	Bushing
27.	GD10226	12	Finger, Oil Sunflower
A.	GR0933	-	Finger Assembly, Corn (Items 11-14 And 20)
B.	GR1327	-	Finger Assembly, Oil Sunflower (Items 12-14, 20 And 27)

BRUSH-TYPE SEED METER

RUA037(RU14)

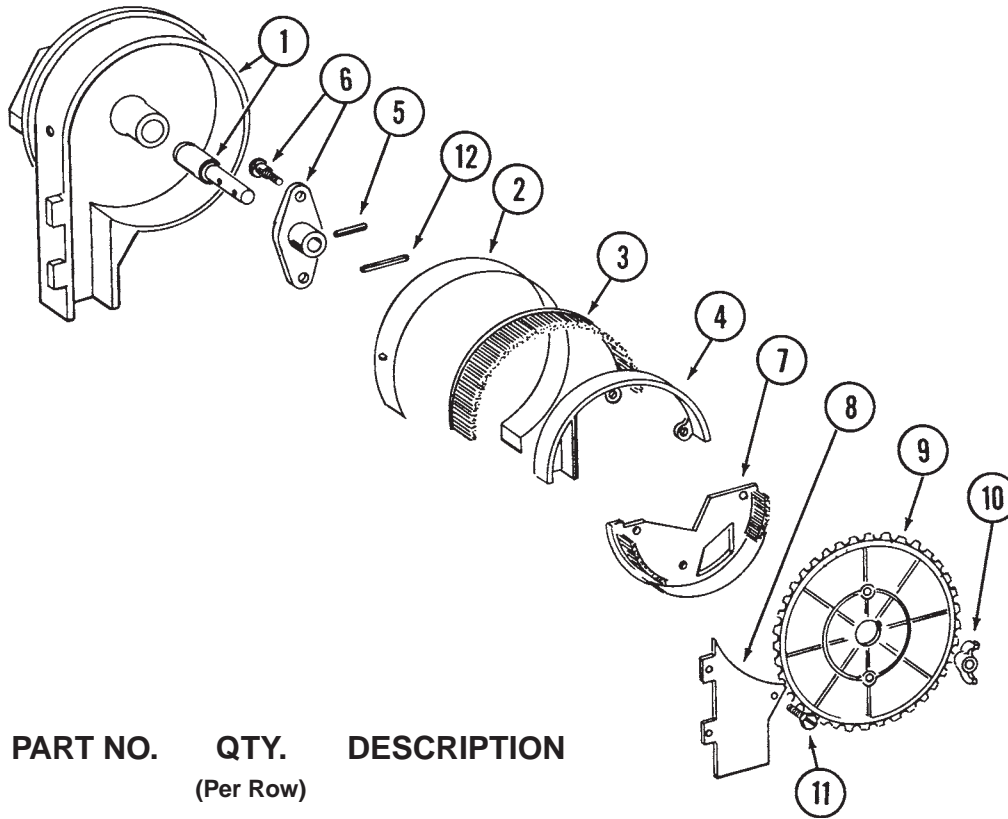

ITEM	PART NO.	QTY. (Per Row)	DESCRIPTION
1.	GA6027	1	Housing W/Bearing
	GA5698	-	Bearing
2.	GD8778	1	Wear Strip
3.	GA5699	1	Upper Retaining Brush
4.	GD8237	1	Retaining Brush Holder
5.	G10603	1	Spring Pin, 1/4" x 1 1/4"
6.	GA6038	1	Hub W/Shoulder Bolts
	GD1755	-	Shoulder Bolt, 1/4"-20 (2 Used)
7.	GA5834	1	Lower Brush
8.	GD7878	1	Cover
9.	GA5794	-	Seed Disc, Soybean, 60 Cell, Black Color-Coded
	GA6184	-	Seed Disc, Specialty Soybean, 48 Cell, Dark Blue Color-Coded
	GA5982	-	Seed Disc, Small Milo/Grain Sorghum, 30 Cell, Red Color-Coded
	GA6187	-	Seed Disc, Large Milo/Grain Sorghum, 30 Cell, Light Blue Color-Coded
	GA5795	-	Seed Disc, High Rate Small Milo/Grain Sorghum, 60 Cell, Red Color-Coded
	GA6633	-	Seed Disc, High Rate Large Milo/Grain Sorghum, 60 Cell, Yellow Color-Coded
	GA5796	-	Seed Disc, Cotton, Acid-Delinted, 30 Cell, White Color-Coded
	GA6168	-	Seed Disc, Large Cotton, Acid-Delinted, 36 Cell, Tan Color-Coded
	GA6478	-	Seed Disc, High Rate Cotton, Acid-Delinted, 48 Cell, Light Green Color-Coded
	GA6182	-	Seed Disc, Hill-Drop Cotton, Acid-Delinted, 12 Cell, Brown Color-Coded
	GA7255	-	Seed Disc, Small Hill-Drop Cotton, Acid-Delinted, 12 Cell, Dark Green Color-Coded
10.	G10531	2	Nylon Insert Wing Nut, 1/4"-20
11.	G10584	9	Slotted Tap Screw, No. 10-24 x 1/2"
12.	G10602	1	Spring Pin, 1/4" x 1 1/2"

GRANULAR CHEMICAL BANDERS

RUA013/RUA016/RUA044(RU16a/RU15)

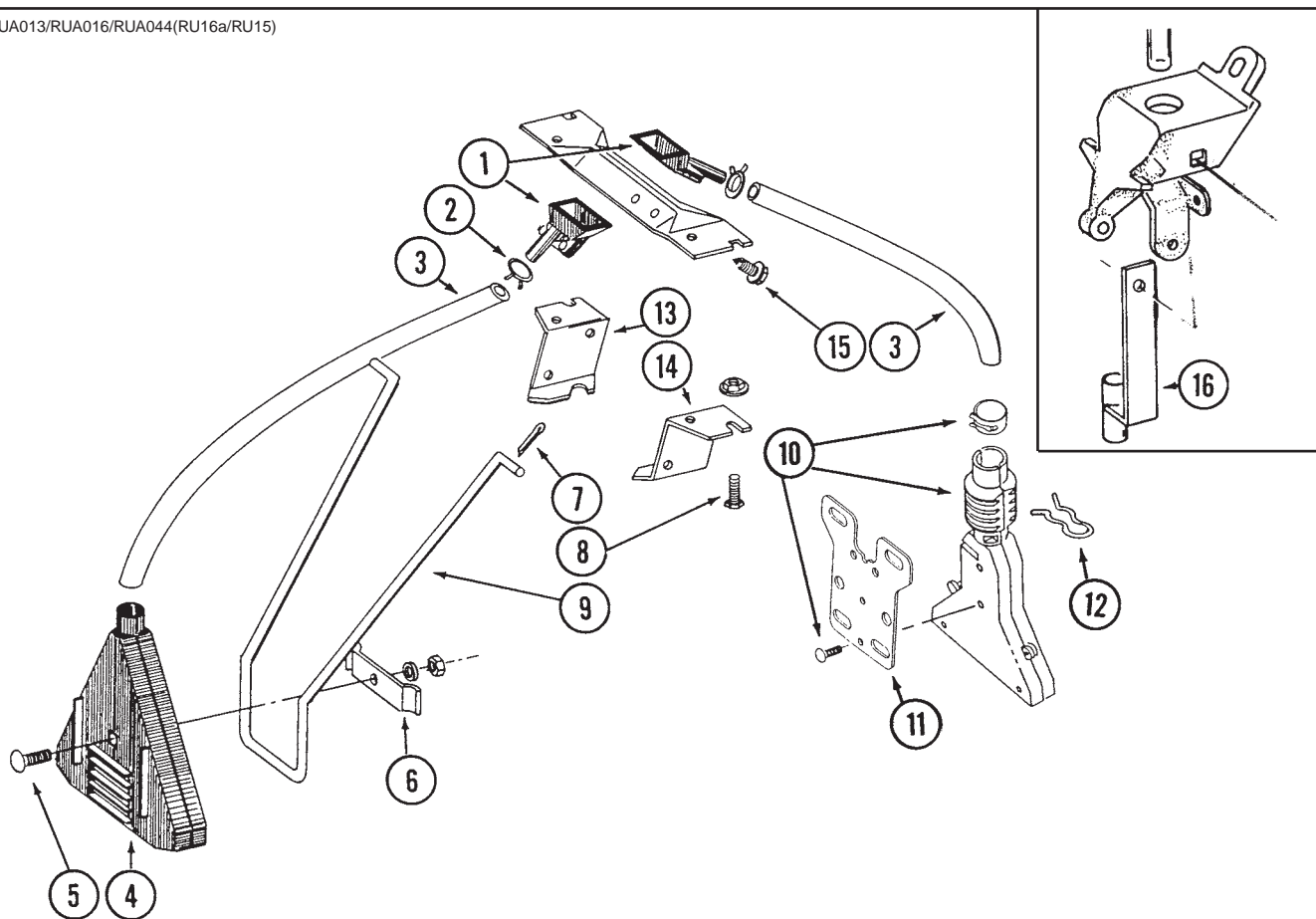

ITEM	PART NO.	QTY.	DESCRIPTION
1.	GD2423	-	Funnel
2.	G10680	-	Hose Clamp, 7/16"
3.	GD2947	-	Hose, 7/16" x 28"
4.	GA2075	-	Diffuser, 14" Band
5.	G10306	-	Carriage Bolt, 3/8"-16 x 2", Grade 2
	G10229	-	Lock Washer, 3/8"
	G10101	-	Hex Nut, 3/8"-16
6.	GD1118	-	Clamp
7.	G10452	-	Cotter Pin, 1/8" x 1/2"
8.	G10310	-	Carriage Bolt, 1/4"-20 x 3/4", Grade 2
	G10227	-	Lock Washer, 1/4"
	G10103	-	Hex Nut, 1/4"-20
9.	GD1116	-	Hanger
10.	GA6907	-	Slope-Compensating Bander W/Hardware (4 1/2" Band Width)
	G10864	-	Uni-Clamp
	G10757	2	Screw, No. 10-32 x 1 1/4"
	G10758	2	Hex Nut, No. 10-32
11.	GD9816	-	Bander Mounting Bracket (For Some Non-KINZE® Applications)
12.	GD1090	-	Spring Clip
13.	GD1115L	-	Hanger Bracket, L.H.
14.	GD1115R	-	Hanger Bracket, R.H.
15.	G10523	-	Self Tapping Screw, No. 10 x 1/2"
16.	GA6741	-	Bracket (Straight Drop In-Furrow)

GRANULAR CHEMICAL SUB-ASSEMBLIES AND KITS

(RU65/RU66/RU67)

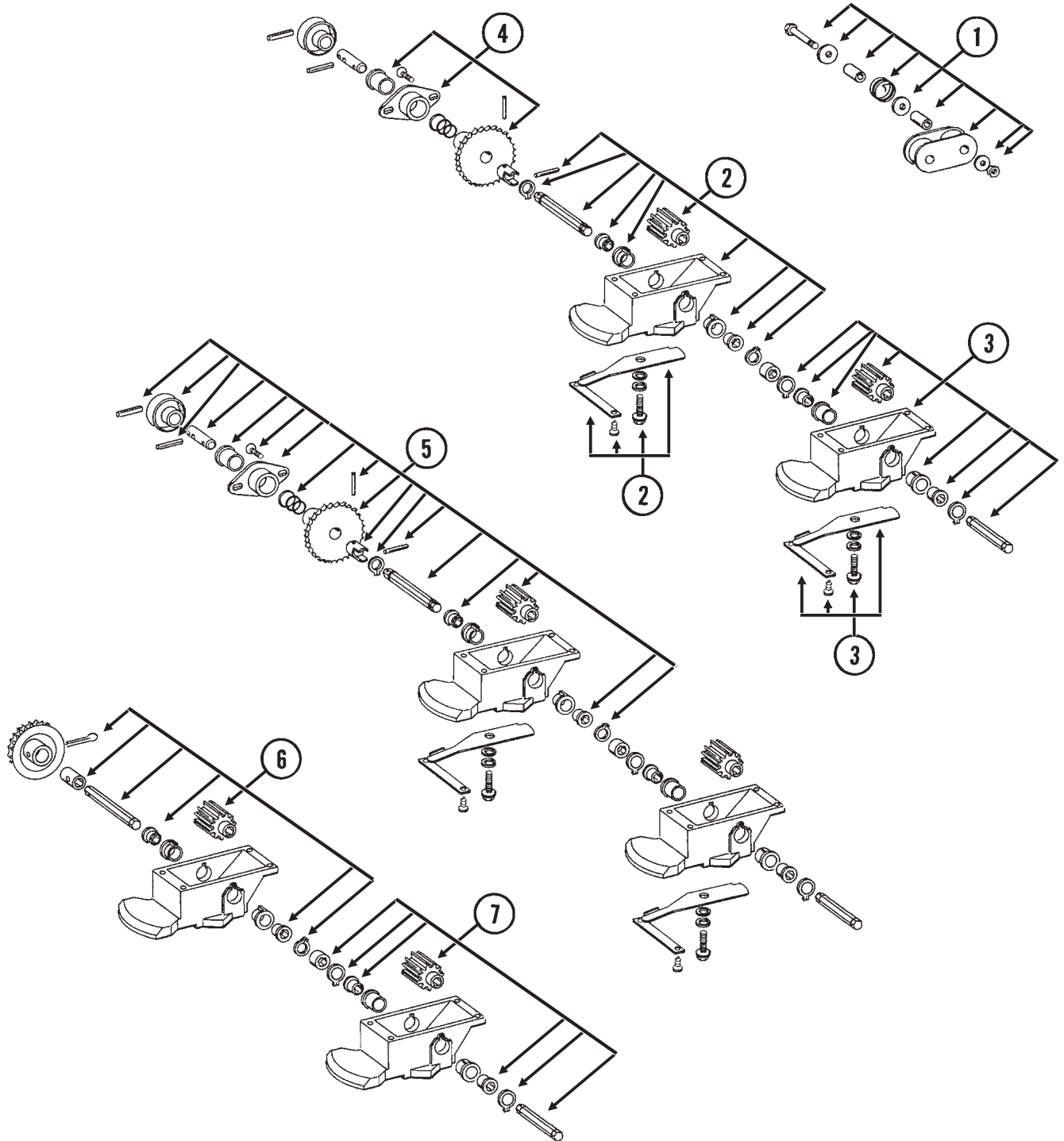

ITEM	PART NO.	QTY.	DESCRIPTION
1.	G1K213	1	Granular Chemical Idler Kit W/Instruction
2.	GA5553	1	Insecticide Housing Sub-Assembly
3.	GA5554	1	Herbicide Housing Sub-Assembly
4.	GA5746	1	Sprocket Sub-Assembly
5.	GA5623	1	Throwout Update Kit W/Instructions And Template
6.	GA5560	1	Primary Meter Roller Replacement Kit W/Instruction (Update For Non-Current Design)
7.	GA5561	1	Secondary Meter Roller Replacement Kit W/Instruction (Update For Non-Current Design)

GRANULAR CHEMICAL HOPPER WITH METER(S) & THROWOUT

RUA006/RUA008/RUA033/RUA034/RUA044(RU18c/RU19a)

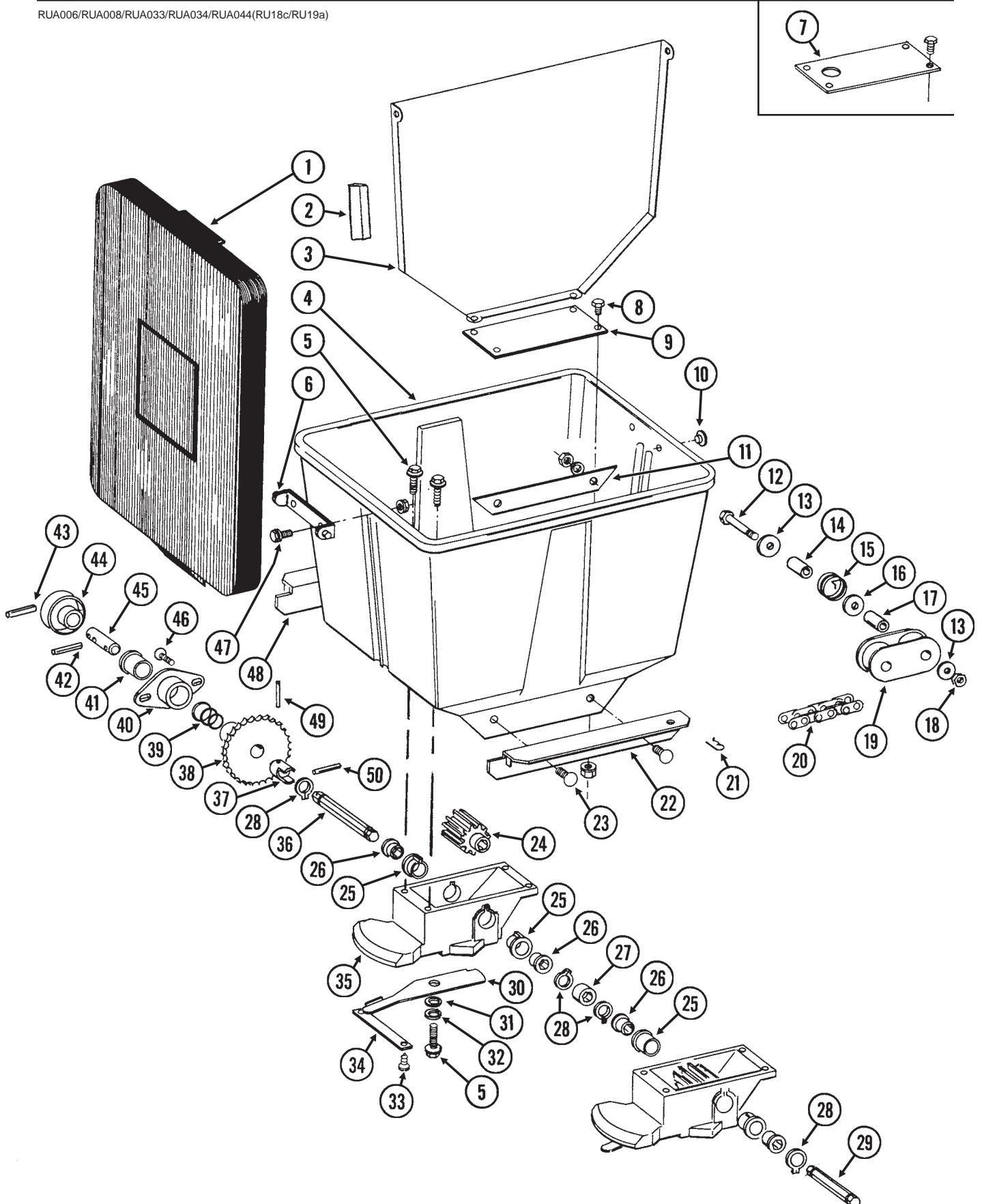

GRANULAR CHEMICAL HOPPER WITH METER(S) & THROWOUT

ITEM	PART NO.	QTY. (Per Row)	DESCRIPTION
1.	GA4444	1	Lid
2.	G3314-40	-	Foam Strip, 40"
3.	GA2076	1	Divider (Used With Two Meters)
4.	GD1058	1	Hopper
5.	G10570	-	Self Tapping Screw, 1/4" x 3/4" (4 Used Per Meter)
6.	GD1060	1	Hinge
7.	GD8750	-	Restrictor Plate (Optional)
8.	G10022	4	Hex Head Cap Screw, 1/4"-20 x 1/2"
	G10621	4	Flange Nut, 1/4"-20
9.	GD1056	-	Cover Plate (1 Used With One Meter)
10.	GD1089	2	Plug
11.	GD1072	2	Strap
12.	G10049	1	Hex Head Cap Screw, 3/8"-16 x 2 1/2"
13.	G10210	2	Washer, 3/8" USS
14.	GD2971-10	1	Bushing, 9/16"
15.	GD11219	1	Spring
16.	G10201	1	Special Washer
17.	GD1026	1	Spacer, 1 3/16"
18.	G10108	1	Lock Nut, 3/8"-16
19.	GD9240	1	Idler
20.	G3303-114	1	Roller Chain, No. 41, 114 Pitch Including Connector Link
	GR0196	1	Connector Link, No. 41
21.	G10670	2	Spring Locking Pin, No. 3
22.	GD1059R	1	Support, R.H.
23.	G10311	4	Carriage Bolt, 3/8"-16 x 3/4" Short Necked, Grade 2
	G10229	4	Lock Washer, 3/8"
	G10101	4	Hex Nut, 3/8"-16
24.	GD7148	-	Feed Roller, Hex Bore (1 Used Per Meter)
25.	GB0115	-	Bearing (2 Used Per Meter)
26.	GD7258	-	Hex Bushing (2 Used Per Meter)
27.	GD7592	1	Coupler, Hex Bore (With 2nd Meter)
28.	G10567	1	Retaining Ring
29.	GD7591	-	Shaft (1 Used In 2nd Meter)
30.	GD1063	-	Metering Gate (1 Used Per Meter)
31.	G10660	-	Wave Washer (1 Used Per Meter)
32.	G10209	-	Washer, 1/4" USS (1 Used Per Meter)
33.	G10521	1	Self Tapping Screw, No. 10 x 3/8" (2 Used Per Meter)
34.	GD1061	-	Support Strap (1 Used Per Meter)
35.	GB0116	-	Granular Housing (1 Used Per Meter)
36.	GD7588	1	Shaft
37.	GB0184	1	Coupling
38.	GA5533	1	Sprocket, 24 Tooth
39.	GD10464	1	Spring
40.	GB0183	1	Bearing Mount
41.	GB0121	1	Bearing
42.	G10602	1	Spring Pin, 1/4" x 1 1/2"
43.	G10637	1	Spring Pin, 1/8" x 1 1/2"
44.	GD11239	1	Knob
45.	GD7589	1	Throwout Pin
46.	G10312	2	Carriage Bolt, 5/16"-18 x 3/4"
	G10620	2	Flange Nut, 5/16"-18
47.	G10023	2	Hex Head Cap Screw, 1/4"-20 x 3/4"
	G10621	2	Flange Nut, 1/4"-20
48.	GD1059L	1	Support, L.H.
49.	G10609	1	Spring Pin, 5/32" x 1"
50.	G10546	1	Spring Pin, 3/16" x 1 1/4"

SPRING TOOTH INCORPORATOR

RUA011(RU20)

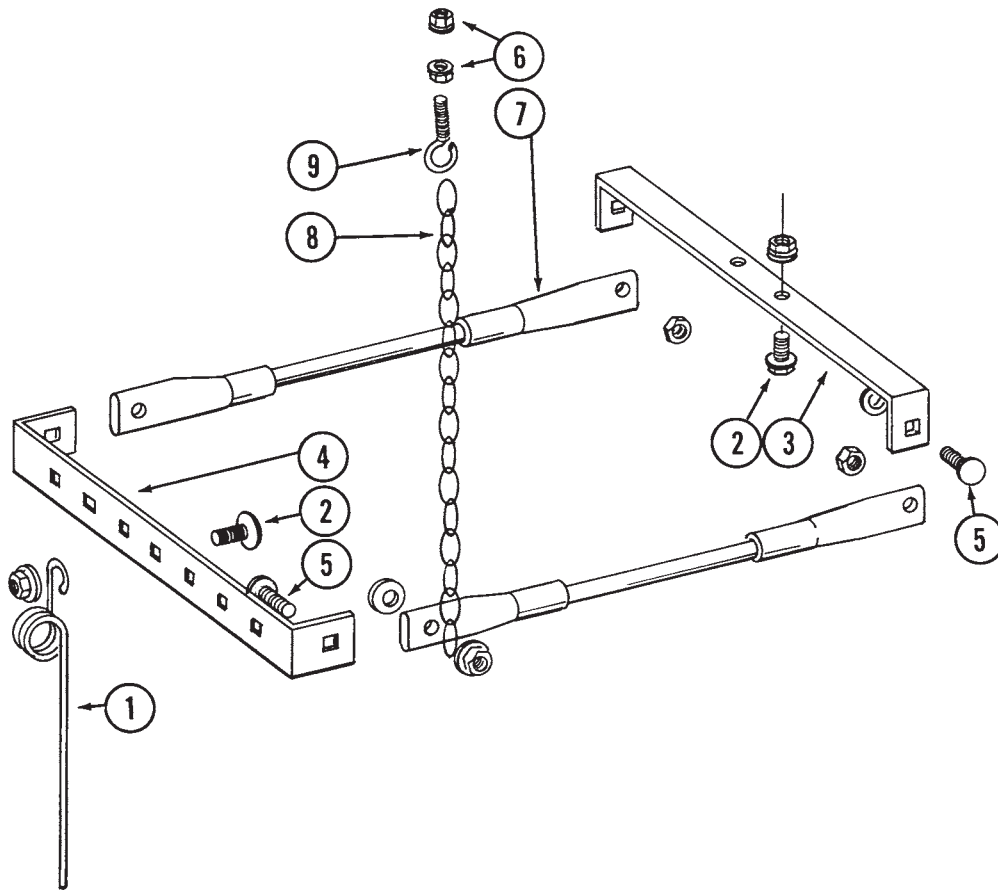

ITEM	PART NO.	QTY. (Per Row)	DESCRIPTION
1.	GD1145	7	Spring Tooth
2.	G10308	9	Carriage Bolt, 3/8"-16 x 3/4", Grade 2
	G10622	9	Flange Nut, 3/8"-16
3.	GD1143	1	Front Bracket
4.	GD1144	1	Rear Bracket
5.	G10305	4	Carriage Bolt, 3/8"-16 x 1", Grade 2
	G10529	4	External Tooth Lock Washer, 3/8"
	G10622	4	Flange Nut, 3/8"-16
6.	G10621	4	Flange Nut, 1/4"-20
7.	GA2094	2	Cable Assembly
8.	G3305-01	4	Chain
9.	GD2460	2	Eyebolt, 1/4"-20

NO TILL COULTER, ROW UNIT MOUNTED

RUA036(RU21a)

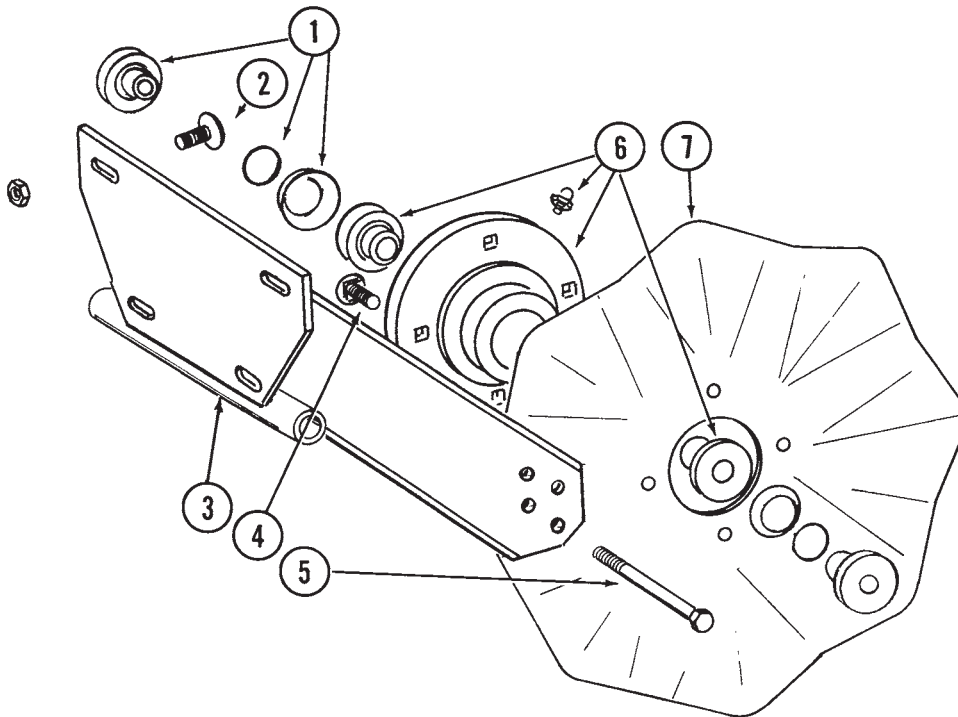

ITEM	PART NO.	QTY. (Per Row)	DESCRIPTION
1.	GB0227	2	Adapter W/O-Ring And Spring Washer
	GD8844	2	O-Ring
	GD8843	2	Spring Washer
2.	G10574	4	Carriage Bolt, 1/2"-13 x 1 1/4"
	G10111	4	Lock Nut, 1/2"-13
3.	GA5625	1	Arm
4.	G10574	4	Carriage Bolt, 1/2"-13 x 1 1/4"
	G10111	4	Lock Nut, 1/2"-13
5.	G10036	1	Hex Head Cap Screw, 5/8"-11 x 4"
	G10107	1	Lock Nut, 5/8"-11
6.	GA5640	1	Hub W/Bearings And Grease Fitting
	GA5622	-	Bearing (2 Used)
	G10640	-	Grease Fitting, 1/4"-28
7.	GD7803	-	Fluted Blade, 1", 8 Flutes (Shown)
	GD7804	-	Bubbled Blade, 1"
	GD9254	-	Fluted Blade, 3/4", 13 Flutes

BED LEVELER, ROW UNIT MOUNTED

RUA038/RUA040(RU22b)

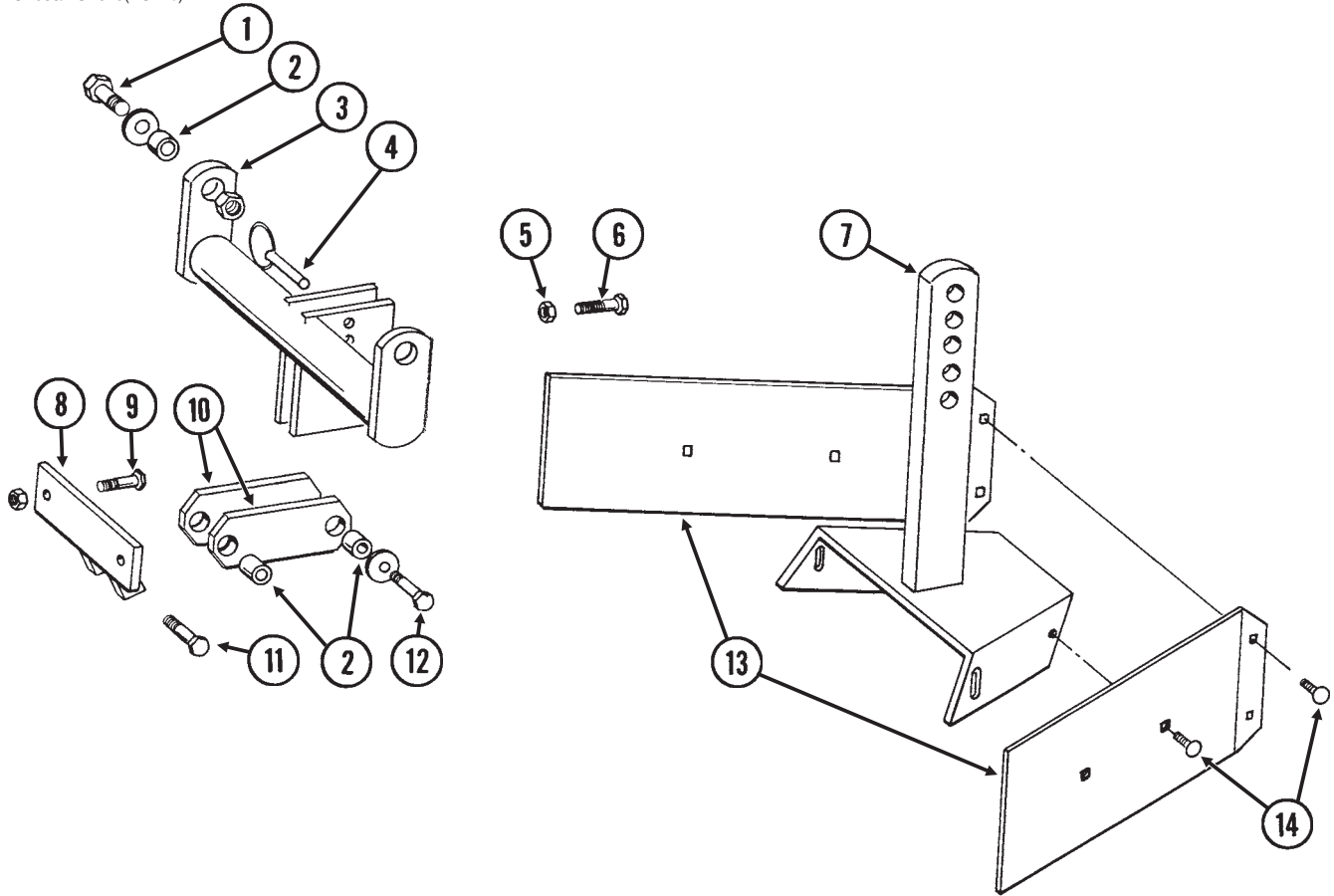

ITEM	PART NO.	QTY. (Per Row)	DESCRIPTION
1.	G10039	2	Hex Head Cap Screw, 1/2"-13 x 1 3/4"
	G10216	2	Washer, 1/2" USS
	G10111	2	Lock Nut, 1/2"-13
2.	GD7889	6	Bushing
3.	GA5719	1	Mounting Bracket
4.	G10536	1	Pin
5.	G10503	1	Jam Nut, 5/8"-11
6.	G10597	1	Set Screw, 5/8"-11 x 2 1/4"
7.	GA5892	1	Leveler
8.	GA5715	1	Anchor
	G10017	2	Hex Head Cap Screw, 1/2"-13 x 1 1/2"
9.	G10111	2	Lock Nut, 1/2"-13
	GD7890	2	Link
10.	G10017	2	Hex Head Cap Screw, 1/2"-13 x 1 1/2"
	G10216	2	Washer, 1/2" USS
	G10111	2	Lock Nut, 1/2"-13
11.	G10017	2	Hex Head Cap Screw, 1/2"-13 x 1 1/2"
	G10216	2	Washer, 1/2" USS
	G10111	2	Lock Nut, 1/2"-13
12.	G10585	1	Hex Head Cap Screw, 1/2"-13 x 3 1/4"
	G10216	2	Washer, 1/2" USS
	G10111	1	Lock Nut, 1/2"-13
13.	GD8266	2	Blade
14.	G10303	6	Carriage Bolt, 5/16"-18 x 1"
	G10219	4	Washer, 5/16" USS
	G10109	6	Lock Nut, 5/16"-18

DISC FURROWER, ROW UNIT MOUNTED

RUA038/RUA040(RU23a)

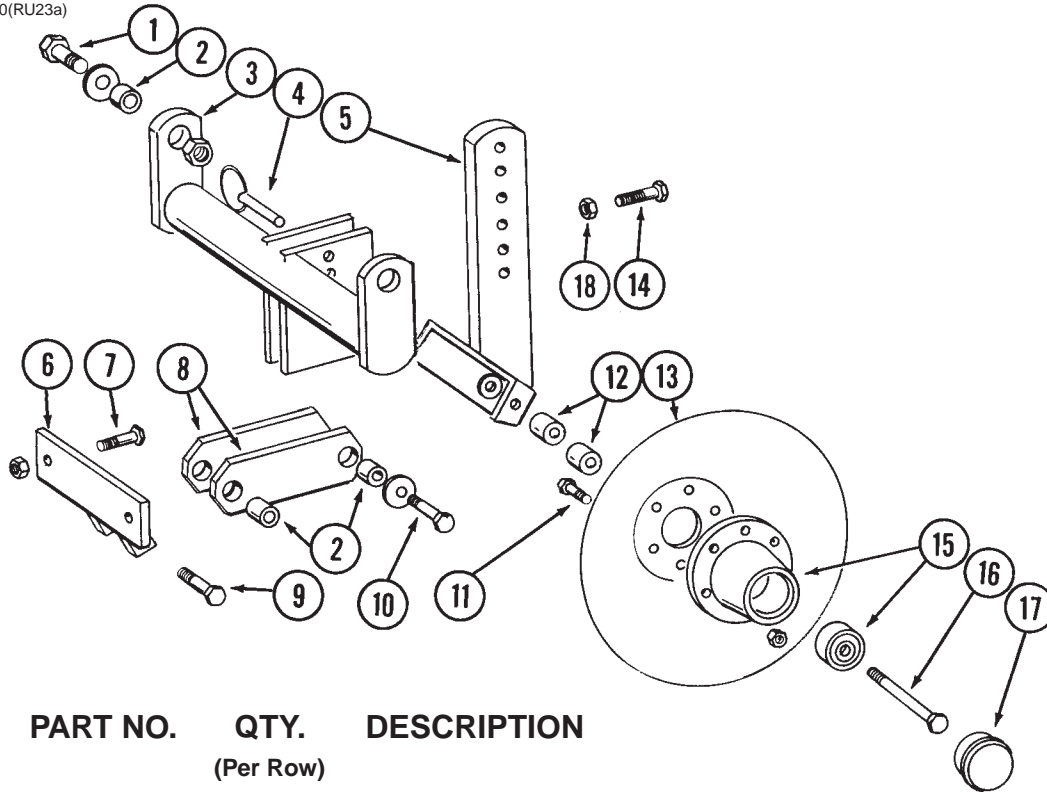

ITEM	PART NO.	QTY. (Per Row)	DESCRIPTION
1.	G10039	2	Hex Head Cap Screw, 1/2"-13 x 1 3/4"
	G10216	2	Washer, 1/2" USS
	G10111	2	Lock Nut, 1/2"-13
2.	GD7889	6	Bushing
3.	GA5719	1	Mounting Bracket
4.	G10536	1	Pin
5.	GA5718	1	Support Arm
6.	GA5715	1	Anchor
7.	G10017	2	Hex Head Cap Screw, 1/2"-13 x 1 1/2"
	G10111	2	Lock Nut, 1/2"-13
8.	GD7890	2	Link
9.	G10017	2	Hex Head Cap Screw, 1/2"-13 x 1 1/2"
	G10216	2	Washer, 1/2" USS
	G10111	2	Lock Nut, 1/2"-13
10.	G10585	1	Hex Head Cap Screw, 1/2"-13 x 3 1/4"
	G10216	2	Washer, 1/2" USS
	G10111	1	Lock Nut, 1/2"-13
11.	G10572	6	Truss Head Slotted Machine Screw, 5/16"-18 x 7/8"
	G10106	6	Hex Nut, 5/16"-18
12.	GD7817-01	2	Spacer, 3/4"
	GD7817-04	2	Spacer, 1/2"
13.	GD7823	-	Solid Blade, 12" (Shown)
	GD8307	-	Notched Blade, 12"
14.	G10597	1	Set Screw, 5/8"-11 x 2 1/4"
15.	GA5654	2	Hub W/Bearings
	GA2014	-	Bearing
16.	G10318	2	Hex Head Cap Screw, 5/8"-11 x 4 1/2"
	GD7805	2	Special Washer
	G10107	2	Lock Nut, 5/8"-11
17.	GD1132	2	Dust Cap
18.	G10503	1	Jam Nut, 5/8"-11

RESIDUE WHEEL, ROW UNIT MOUNTED

RUA041/RUA045(RU24b)

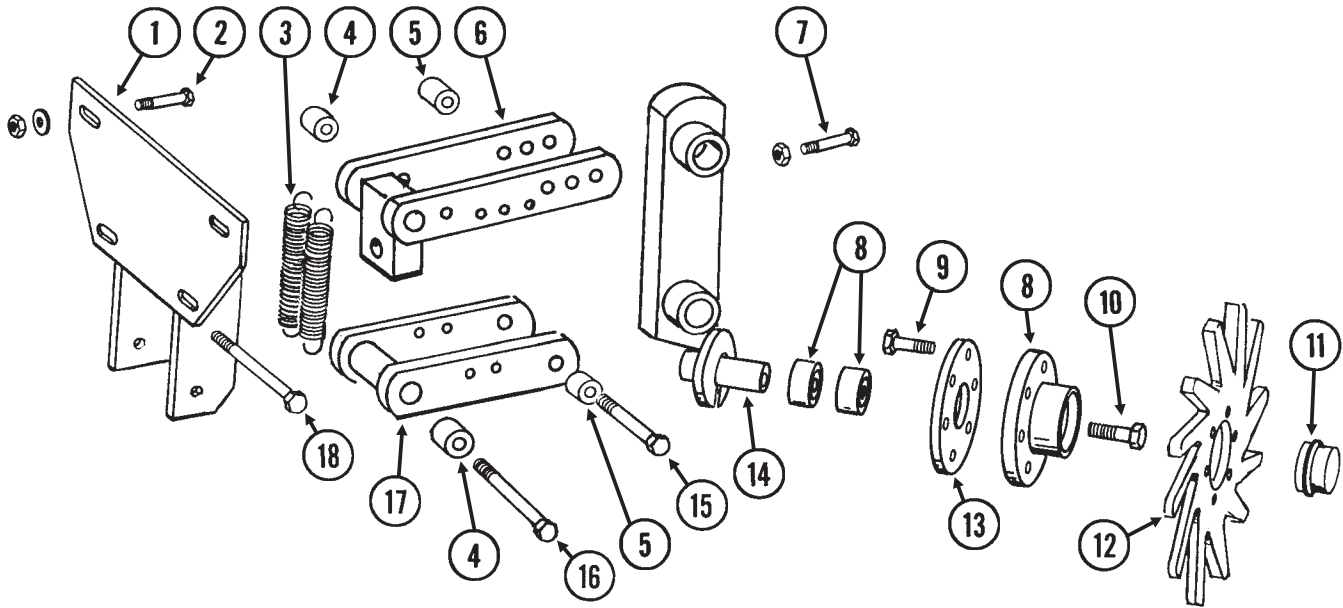

ITEM	PART NO.	QTY.	DESCRIPTION
		(Per Row)	
1.	GA6832	1	Mount
2.	G10574	4	Carriage Bolt, 1/2"-13 x 1 1/4"
	G10216	4	Washer, 1/2" USS
	G10111	4	Lock Nut, 1/2"-13
3.	GD5857	2	Spring
4.	GD9715	2	Spacer, 2 5/16"
5.	GD9720	2	Spacer, 2 3/16"
6.	GA6833	1	Upper Link
7.	G10371	1	Hex Head Cap Screw, 1/2"-13 x 3", Full Thread
	G10501	1	Jam Nut, 1/2"-13
8.	GA5654	2	Hub W/Bearings
	GA2014	-	Bearing
9.	G10133	6	Hex Head Cap Screw, 5/16"-18 x 1 1/2"
	G10109	6	Lock Nut, 5/16"-18
10.	G10006	1	Hex Head Cap Screw, 5/8"-11 x 2 1/4"
11.	GD1132	1	Dust Cap
12.	GD10552	1	Wheel, 3/8" x 12"
13.	GD9724	1	Backing Plate
14.	GA6838	1	Wheel Mount
15.	G10033	2	Hex Head Cap Screw, 1/2"-13 x 3 1/2"
	G10228	2	Lock Washer, 1/2"
	G10102	2	Hex Nut, 1/2"-13
16.	G10045	2	Hex Head Cap Screw, 1/2"-13 x 4 1/2"
	G10228	2	Lock Washer, 1/2"
	G10102	2	Hex Nut, 1/2"-13
17.	GA6834	1	Lower Link
18.	G10348	1	Hex Head Cap Screw, 1/2"-13 x 5" (Lockup Bolt)
	G10111	1	Lock Nut, 1/2"-13
A.	GA7446	-	Wheel Assembly (Items 8, 9, 12 And 13)

RESIDUE WHEELS, COULTER MOUNTED

RUA047(RU31a)

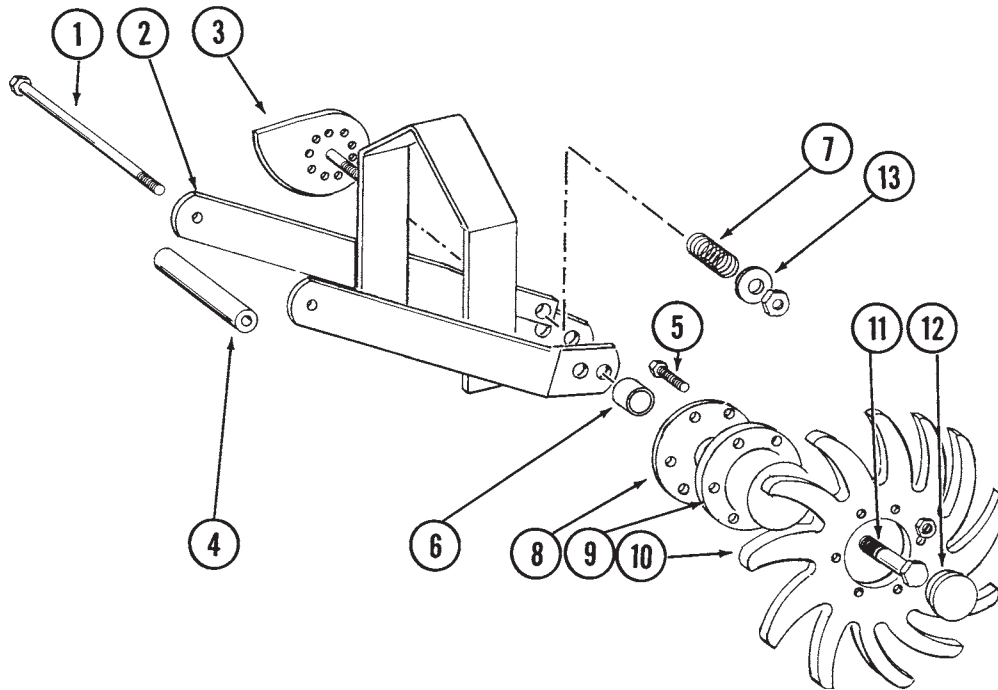

ITEM	PART NO.	QTY. (Per Row)	DESCRIPTION
1.	G10148	1	Hex Head Cap Screw, 1/2"-13 x 9 1/2"
	G10111	1	Lock Nut, 1/2"-13
2.	GA7271	1	Mount
3.	GA7412	1	Cam
4.	GD10526	1	Sleeve, 7 1/2"
5.	G10133	12	Hex Head Cap Screw, 5/16"-18 x 1 1/2"
	G10109	12	Lock Nut, 5/16"-18
6.	GD7817-04	2	Spacer, 1 1/4" O.D. x 1/2" Long
7.	GD10519	1	Spring
8.	GD9724	2	Backing Plate
9.	GA5654	2	Hub W/Bearings
	GA2014	-	Bearing
10.	GD10552	2	Wheel, 3/8" x 12"
11.	G10009	2	Hex Head Cap Screw, 5/8"-11 x 2 1/2"
12.	GD1132	2	Dust Cap
13.	G10206	1	Washer, 1/2" SAE
	G10111	1	Lock Nut, 1/2"-13
A.	GA7446	-	R.H. Wheel Assembly (Items 5 And 8-10) (Shown)
	GA7445	-	L.H. Wheel Assembly (Items 5 And 8-10)

FRAME MOUNTED COULTER W/DISC FURROWER

RUA035/RUB016(RU25a)

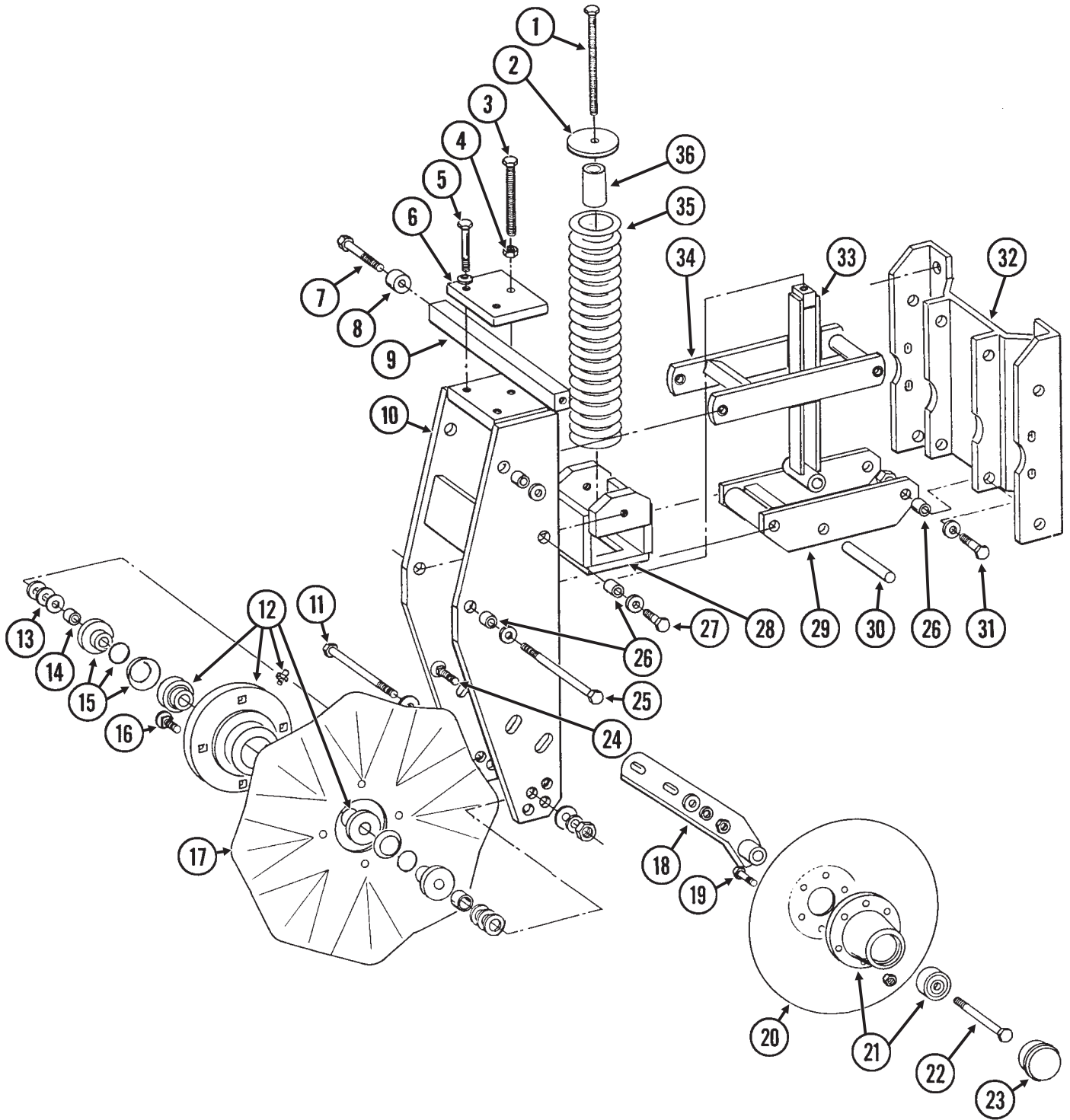

FRAME MOUNTED COULTER W/DISC FURROWER

ITEM	PART NO.	QTY. (Per Row)	DESCRIPTION
1.	G10573	1	Hex Head Cap Screw, 5/8"-11 x 5 1/2", Full Thread
2.	GB0196	1	Washer
3.	G10582	1	Hex Head Cap Screw, 5/8"-11 x 4", Full Thread
4.	G10104	1	Hex Nut, 5/8"-11
5.	G10581	2	Hex Head Cap Screw, 1/2"-13 x 2 1/4"
	G10228	2	Lock Washer, 1/2"
6.	GD7811	1	Depth Adjustment Clamp
	G10107	4	Lock Nut, 5/8"-11 (As Required)
7.	GD7818	2	Special Bolt
8.	GD7817-01	2	Roller, 3/4"
9.	GD7816	1	Depth Control Bar
10.	GA5643	1	Fork Mount
11.	G10068	1	Hex Head Cap Screw, 5/8"-11 x 6"
	G10107	1	Lock Nut, 5/8"-11
12.	GA5640	1	Hub W/Bearings And Grease Fitting
	GA5622	-	Bearing (2 Used Per Hub)
	G10640	-	Grease Fitting, 1/4"-28
13.	G10217	-	Washer, 5/8" USS (As Required)
14.	GD7817-04	2	Spacer, 1/2"
15.	GB0227	2	Adapter W/O-Ring And Spring Washer
	GD8844	-	O-Ring
	GD8843	-	Spring Washer
16.	G10574	4	Carriage Bolt, 1/2"-13 x 1 1/4"
	G10111	4	Lock Nut, 1/2"-13
17.	GD7803	-	Fluted Blade, 1", 8 Flutes (Shown)
	GD7804	-	Bubbled Blade, 1"
	GD9254	-	Fluted Blade, 3/4", 13 Flutes
18.	GA5636	2	Arm
19.	G10572	12	Truss Head Slotted Machine Screw, 5/16"-18 x 7/8"
	G10106	12	Hex Nut, 5/16"-18
20.	GD7823	-	Solid Blade, 12" (Shown)
	GD8307	-	Notched Blade, 12"
21.	GA5654	2	Hub W/Bearings
	GA2014	4	Bearing
22.	G10036	2	Hex Head Cap Screw, 5/8"-11 x 4"
	G10107	2	Lock Nut, 5/8"-11
23.	GD1132	2	Dust Cap
24.	G10747	4	Carriage Bolt, 1/2"-13 x 2"
	G10206	-	Washer, 1/2" SAE (As Required)
	G10228	4	Lock Washer, 1/2"
	G10102	4	Hex Nut, 1/2"-13
25.	G10012	1	Hex Head Cap Screw, 5/8"-11 x 6 1/2"
	GD7805	2	Washer
	G10107	1	Lock Nut, 5/8"-11
26.	GB0218	10	Bushing, 1 9/32"
27.	G10055	2	Hex Head Cap Screw, 5/8"-11 x 1 1/4"
	GD7805	2	Washer
28.	GA5637	1	Spring Socket
29.	GA5631	1	Lower Parallel Link
30.	GD7815	1	Pin, 5/8" x 4 1/4"
31.	G10008	6	Hex Head Cap Screw, 5/8"-11 x 2"
	GD7805	6	Washer
32.	GA5798	1	Support Plate
33.	GA5635	1	Spring Guide
34.	GA5630	1	Upper Parallel Link
35.	GD7831	1	Compression Spring
36.	GD7817-09	1	Stop, 1 3/4"

CENTER FRAME ASSEMBLY

PFA074/PHA040/PHA046(SFP21/SFP20/SFP19)

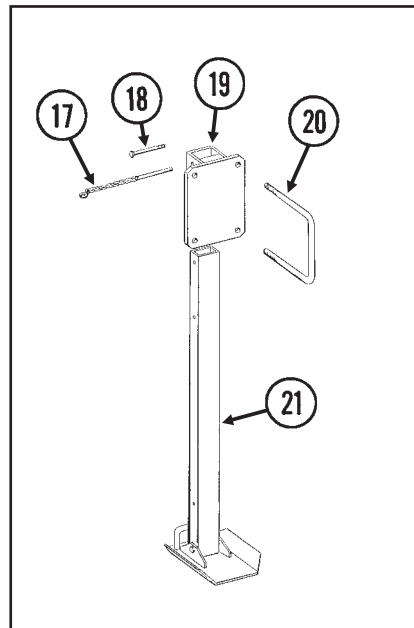
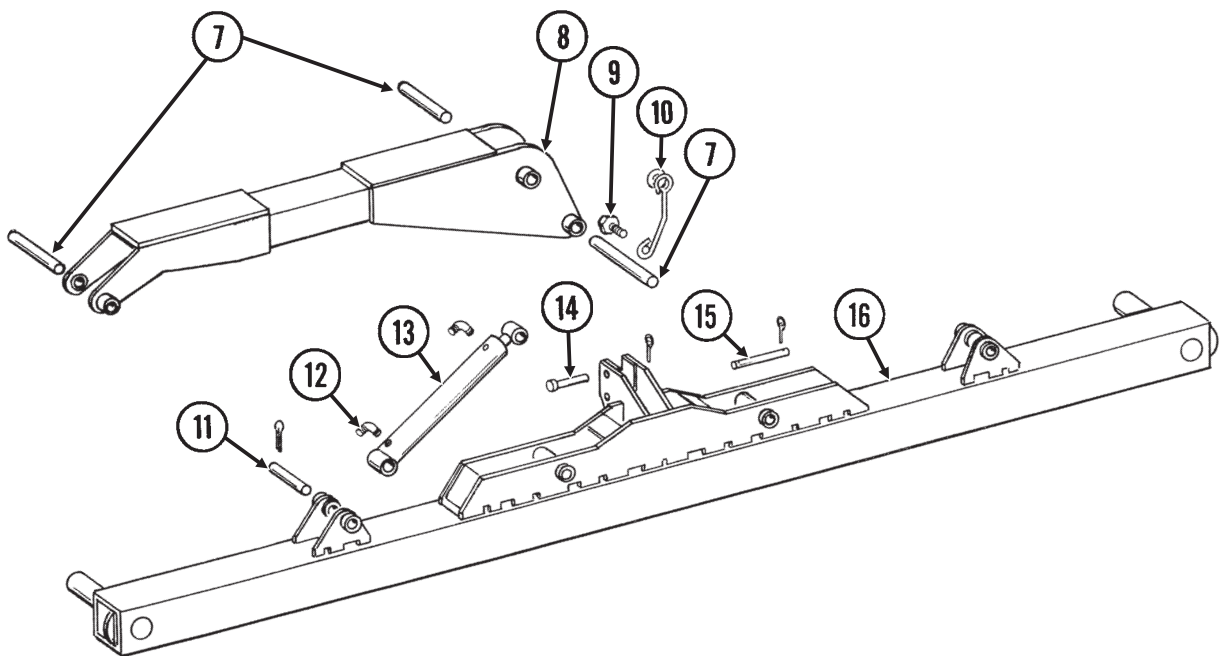
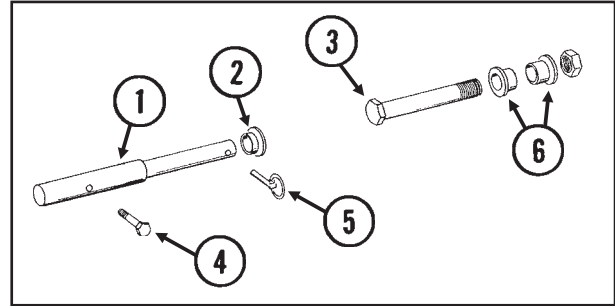

CENTER FRAME ASSEMBLY

ITEM	PART NO.	QTY.	DESCRIPTION
1.	GD9750	2	Lower Hitch Pin, Category 2
2.	GD10418	2	Bushing, Category 2
3.	G10151	1	Hex Head Cap Screw, 1"-8 x 6", Upper Hitch Pin, Category 2
	G10396	1	Lock Nut, 1"-8
4.	G10048	2	Hex Head Cap Screw, 3/8"-16 x 2"
	G10108	2	Lock Nut, 3/8"-16
5.	GD2558	2	Lynch Pin, 1/4"
6.	GD10419	2	Top Link Bushing, Category 2
7.	GD10450	6	Pin, 1 1/4" x 11 1/4"
	G10159	12	Machine Bushing
	G10139	-	Washer, 1 1/4" USS
	G10460	12	Cotter Pin, 1/4" x 2"
8.	GA7349	2	Arm W/Grease Fittings, 74", 8 Row 38"/40" And 12 Row 30"
	GA7359	2	Arm W/Grease Fittings, 93 1/2", 12 Row 36"/38"/40" And 16 Row 30"
	G10641	-	Grease Fitting, 1/8" NPT
9.	G10689	1	Carriage Bolt, 5/8"-11 x 2"
	G10217	1	Washer, 5/8" USS
	G10107	1	Lock Nut, 5/8"-11
10.	GD10456	1	Hose Holder
11.	GD10486	2	Pin, 1 1/4" x 9"
	G10159	4	Machine Bushing
	G10460	4	Cotter Pin, 1/4" x 2"
12.			See "Fold Hydraulic System", Page P59
13.			See "Wing Fold Cylinder", Page P67
14.	GA4666	1	Upper Hitch Pin, Category 3
	GD2557	1	Lynch Pin, 7/16"
15.	GD9333	2	Lower Hitch Pin, Category 3
	GD2557	4	Lynch Pin, 7/16"
16.	A7331	1	Center Toolbar W/Grease Fittings, 7" x 7" x 167", 8 Row 38"/40" And 12 Row 30" (Non-Stock Item)
	A7804	1	Center Toolbar W/Grease Fittings, 7" x 7" x 226", 12 Row 36"/38"/40" And 16 Row 30" (Non-Stock Item)
	G10641	4	Grease Fitting, 1/8" NPT
17.	GA7466	2	Detent Pin W/Chain
18.	G10585	2	Hex Head Cap Screw, 1/2"-13 x 3 1/4"
	G10111	2	Lock Nut, 1/2"-13
19.	GA7334	2	Mount
20.	GD1114	4	U-Bolt, 7" x 7" x 5/8"-11
	G10230	8	Lock Washer, 5/8"
	G10104	8	Hex Nut, 5/8"-11
21.	GA7467	2	Parking Stand
A.	G1K231	-	Category 3 To Category 2 Conversion Kit (Items 1-6)

WING ASSEMBLY

PFA75/PFA55/PFA076/PFA074(SFP18/SFP15/SFP16a)

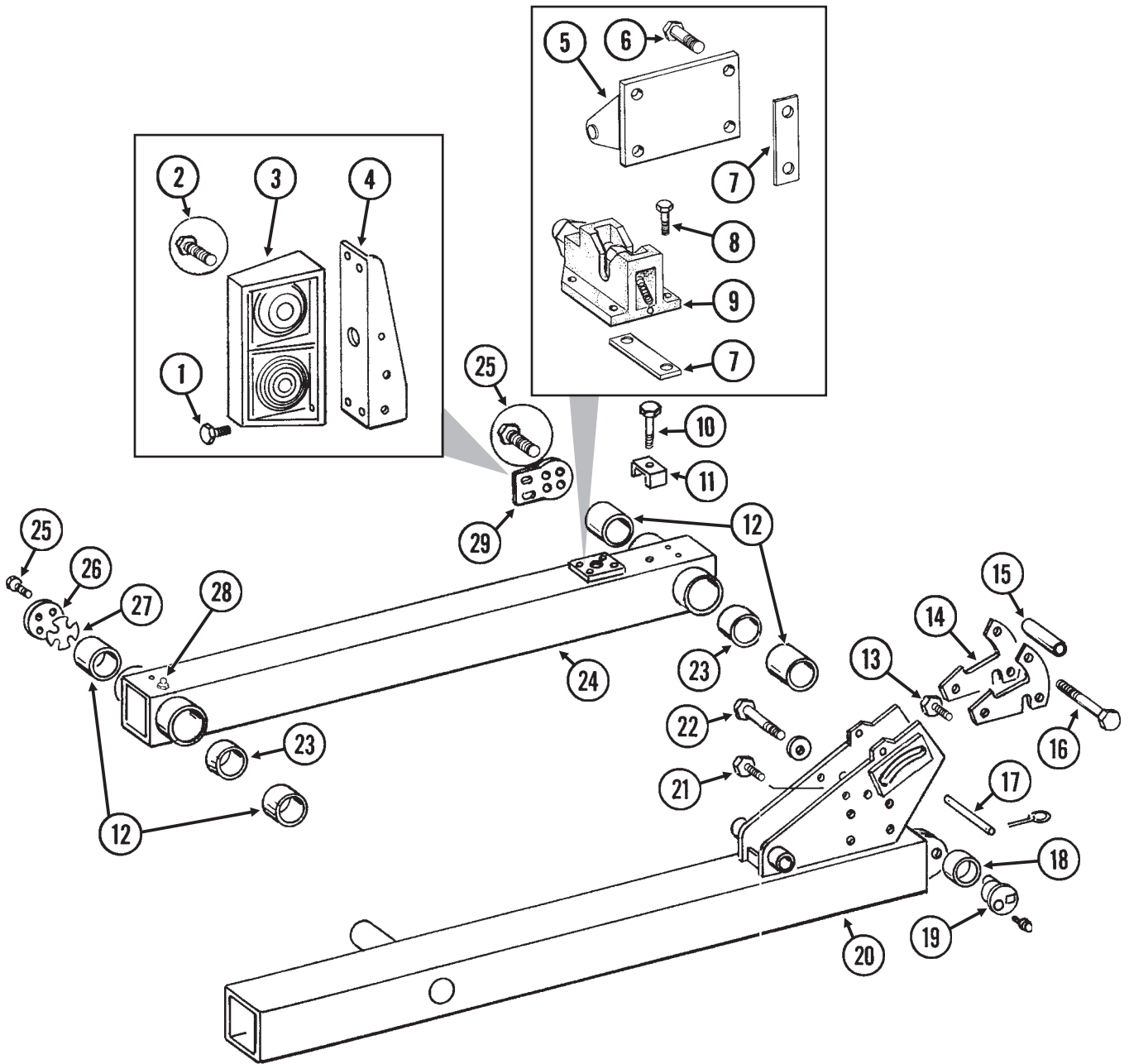

WING ASSEMBLY

ITEM	PART NO.	QTY.	DESCRIPTION
1.	G10064	8	Hex Head Cap Screw, 1/4"-20 x 1"
	G10110	8	Lock Nut, 1/4"-20
2.	G10023	4	Hex Head Cap Screw, 1/4"-20 x 3/4"
	G10209	4	Washer, 1/4" USS
	G10110	4	Lock Nut, 1/4"-20
3.			See "Electrical Components", Page P76
4.	GD9707	1	Light Bracket, R.H.
	GD9708	-	Light Bracket, L.H. (Shown)
5.	GA7346	2	Catch
6.	G10039	8	Hex Head Cap Screw, 1/2"-13 x 1 3/4"
	G10216	8	Washer, 1/2" USS
	G10228	8	Lock Washer, 1/2"
	G10102	8	Hex Nut, 1/2"-13
7.	GD10432	1	Shim, 1 1/4" x 4 1/2" x .030" (As Required)
	GD10433	1	Shim, 1 1/4" x 4 1/2" x .060" (As Required)
8.	G10003	8	Hex Head Cap Screw, 3/8"-16 x 1 1/2"
	G10229	8	Lock Washer, 3/8"
9.	GA7383	2	Hydraulic Latch
10.	G10047	-	Hex Head Cap Screw, 3/8"-16 x 1 3/4"
	G10003	-	Hex Head Cap Screw, 3/8"-16 x 1 1/2"
	G10229	-	Lock Washer, 3/8"
11.	GD5892	-	Hose Clamp, 5/8" x 1 1/2" x 1 1/2"
12.	GD10378	4	Bronze Bushing, 3"
13.	G10025	2	Hex Head Cap Screw, 3/4"-10 x 1 1/2"
	GD9052	2	Hardened Washer
14.	GD10449	4	Hook
15.	GD10555	2	Sleeve
16.	G10874	2	Hex Head Cap Screw, 1/2"-13 x 6"
	G10111	2	Lock Nut, 1/2"-13
17.	GD10556	2	Pin, 5/8" x 6 3/4"
18.	GD10532	2	Sleeve
19.	GA6497	2	Cam Follower W/Grease Fitting
	G10640	-	Grease Fitting, 1/4"-28
20.	GA7329	1	Wing, L.H., 90 3/4" (Shown), 8 Row 38"/40" And 12 Row 30"
	GA7328	1	Wing, R.H., 90 3/4", 8 Row 38"/40" And 12 Row 30"
	GA7807	1	Wing, L.H., 100", 12 Row 36"/38"
	GA7806	1	Wing, R.H., 100", 12 Row 36"/38"
	GA7361	1	Wing, L.H., 117", 12 Row 38"/40" And 16 Row 30"
	GA7360	1	Wing, R.H., 117", 12 Row 38"/40" And 16 Row 30"
	G10112	4	Lock Nut, 3/4"-10
	GD2558	4	Lynch Pin, 1/4"
21.	G10001	2	Hex Head Cap Screw, 3/8"-16 x 1" (Hook Stop)
	G10108	2	Lock Nut, 3/8"-16
22.	G10027	4	Hex Head Cap Screw, 3/4"-10 x 2 1/2"
	G10218	4	Washer, 3/4" USS
23.	GD10379	2	Sleeve, 2 1/2"
24.	GA7326	2	Link Assembly, 71 1/4", 8 Row 38"/40" And 12 Row 30" (Includes Items 4 And 7)
	GA7357	-	Link Assembly, 87 1/2", 12 Row 36"/38"/40" And 16 Row 30" (Includes Items 4 And 7)
25.	G10016	16	Hex Head Cap Screw, 1/2"-13 x 2"
	G10228	16	Lock Washer, 1/2"
26.	GD10478	2	End Cap
27.	GD10741	-	Shim (.015") (As Required)
	GD11155	-	Shim (.060") (As Required)
28.	G10763	8	Extended Grease Fitting
29.	GA7384	2	Light Bracket

GROUND DRIVE WHEEL ASSEMBLY

PLA029/PLA028/PTD085/HTA014/PLA05(SFP14a)

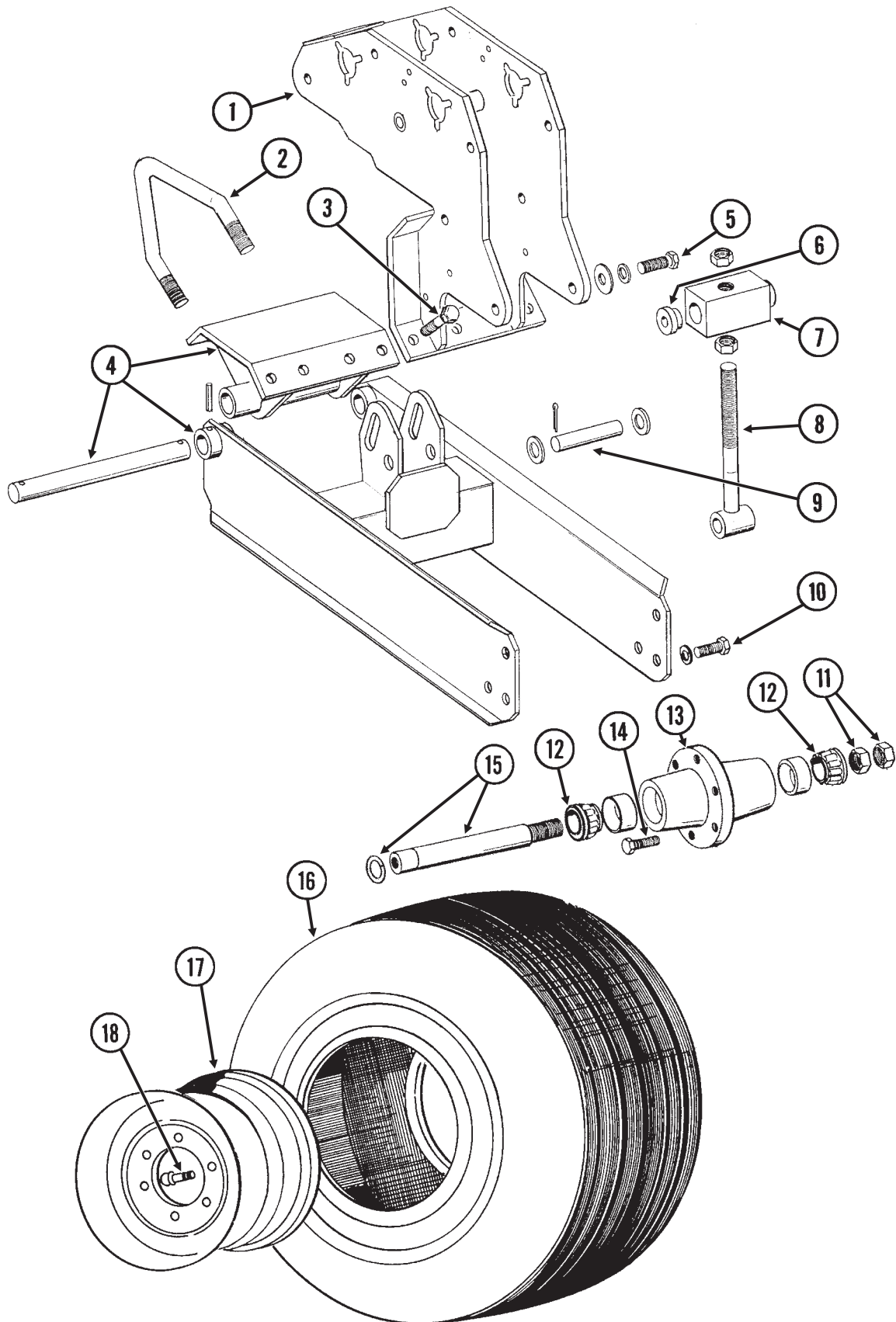

GROUND DRIVE WHEEL ASSEMBLY

ITEM	PART NO.	QTY.	DESCRIPTION
		(Per Assy.)	
1.		-	See "Transmission And Module Drive Assembly", Pages P38 And P39
2.	GD8175	2	U-Bolt, 7" x 7" (Diamond) x 5/8"-11
	GD7805	4	Special Washer
	G10230	4	Lock Washer, 5/8"
	G10104	4	Hex Nut, 5/8"-11
3.	G10005	4	Hex Head Cap Screw, 5/8"-11 x 1 3/4"
	GD7805	4	Special Washer
	G10230	4	Lock Washer, 5/8"
	G10104	4	Hex Nut, 5/8"-11
4.	A7294	1	Arm W/Shaft, Lower Clamp And Spring Pins (Non-Stock Item)
	GD5804	1	Shaft, 1 1/4" x 12"
	GA7295	1	Clamp W/ Grease Fittings
	G10641	-	Grease Fitting, 1/8" NPT
	G10610	-	Spring Pin, 3/8" x 2"
5.	G10026	2	Hex Head Cap Screw, 3/4"-10 x 2"
	G10194	2	Washer, 3/4" SAE
	G10231	2	Lock Washer, 3/4"-10
6.	GD10403	2	Concentric Spacer
7.	GD10328	1	Adjustment Block
8.	GA4705	1	Adjustment Screw
	G10117	2	Hex Nut, 1"-8
9.	GD7041	1	Pin, 1" x 4"
	G10082	2	Washer, 1" SAE
	G10459	2	Cotter Pin, 3/16" x 1 1/2"
10.	G10026	2	Hex Head Cap Screw, 3/4"-10 x 2"
	G10231	2	Lock Washer, 3/4"
11.	G10087	-	Jam Nut, 1 1/2"-10, Grade 2
12.	GA0895	2	Bearing
13.	GA2148	1	Hub W/Cups, 6 Bolt
	GR0434	-	Cup
14.	GR0270	6	Bolt, 9/16"-18
15.	GA2558	1	Spindle W/Round External Retaining Ring, 9 1/2"
	GD11490	-	Round External Retaining Ring
16.	GD0844	1	Tire, 7.60" x 15", 4 Ply (Specify Brand*)
17.	GA5196	1	Wheel W/Valve Protector, 5" x 15"
18.	GD1166	1	Valve Stem
A.	GA2147	-	Hub Assembly (Items 11-15)

* Specific brand requests will be supplied only as available from current KINZE® stock. If a specific brand as requested is not on hand, the brand available will be supplied.

CONTACT DRIVE WHEEL ASSEMBLY

PLA027(SFP9a)

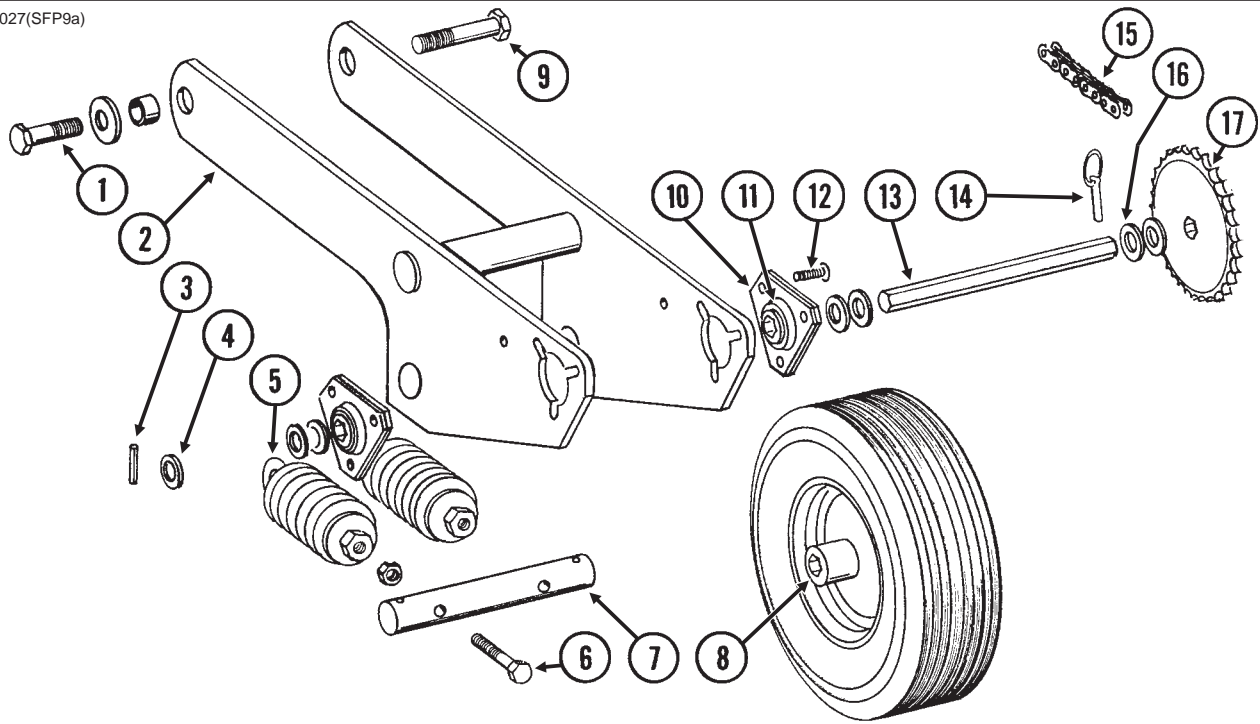

ITEM	PART NO.	QTY. (Per Assy.)	DESCRIPTION
1.	G10005 GD7805 GD3180-15 G10107	1 1 1 1	Hex Head Cap Screw, 5/8"-11 x 1 3/4" Special Washer Sleeve, 15/32" Lock Nut, 5/8"-11
2.	GA7297	1	Arm
3.	G10602	1	Spring Pin, 1/4" x 1 1/2"
4.	G10206	-	Washer, 1/2" SAE
5.	GA2068	2	Spring
6.	G10861 G10501	2 2	Hex Head Adjustment Bolt, 1/2"-13 x 5" Hex Jam Nut, 1/2"-13
7.	GD10329	1	Shaft
8.	GA5090 GD5753 GD5752	1 1 1	Tire And Rim Assembly (Specify Brand*) Tube Type Tire, 4.10" x 6" (Specify Brand*) Tube
9.		-	See "Module Drive", Pages P40 And P41 Item 7
10.	G3400-01	4	Flangette
11.	G2100-03	2	Bearing, 7/8" Hex Bore, Spherical
12.	G10303 G10232 G10106	6 6 6	Carriage Bolt, 5/16"-18 x 1" Lock Washer, 5/16" Hex Nut, 5/16"-18
13.	GD10332	1	Shaft, 7/8" x 11"
14.	GD2558	1	Lynch Pin, 1/4"
15.	G3310-224 G3310-218	1 1	Chain, No. 40, 224 Pitch Including Connector Link Chain, No. 40, 218 Pitch Including Connector Link (Used With Half Rate (2 To 1) Drive Sprocket)
	GR0912	-	Connector Link, No. 40
16.	G10219 G10233	- -	Washer, 5/16" USS Machine Bushing (As Required)
17.	GA5114 GA5105	1 -	Sprocket, 30 Tooth, Standard Rate Drive Sprocket, 15 Tooth, Half Rate (2 To 1) Drive See "Two-Speed Point Row Wrap Spring Clutch", Pages P46 And P47

* Specific brand requests will be supplied only as available from current KINZE® stock. If a specific brand as requested is not on hand, the brand available will be supplied. Different brand tires may have different diameters. Change in tire brand could result in rate changes. To maintain consistent planting rates throughout all rows, it is recommended that all contact tires be of the same brand and be equally inflated.

WING DOWN FLEX CYLINDER PACKAGE

PFA076(SFP17a)

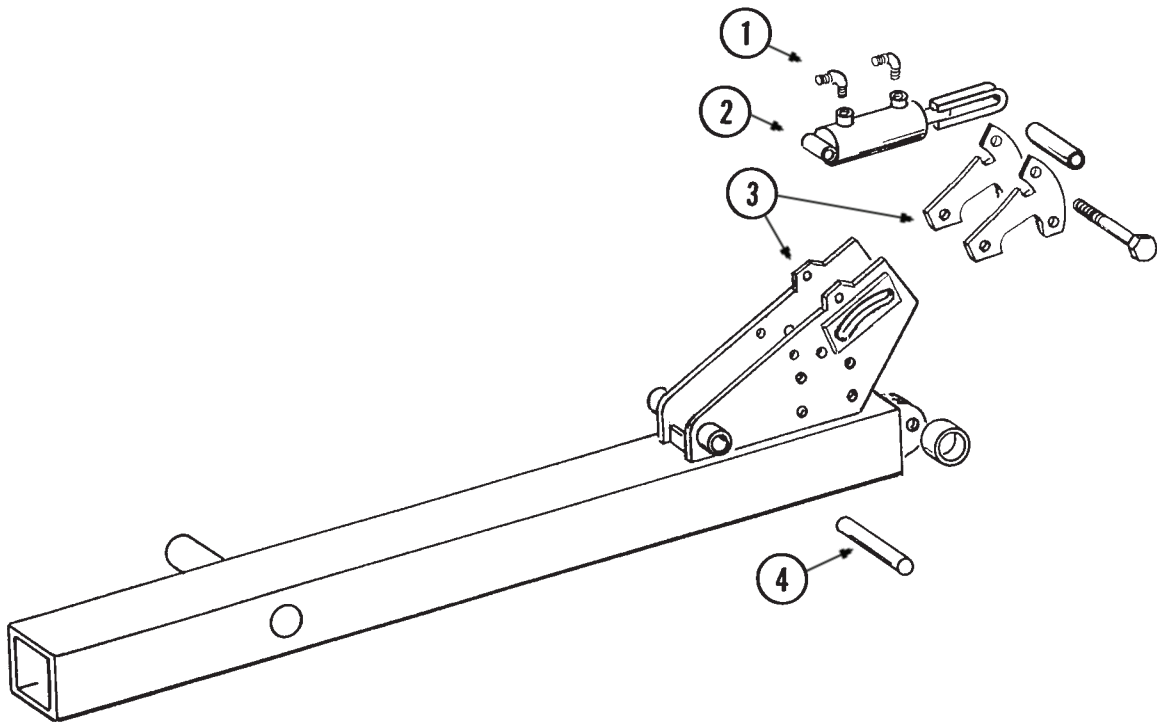

ITEM	PART NO.	QTY. (Per Assy.)	DESCRIPTION
1.		-	See "Wing Down Flex Cylinder Package Hydraulic System", Page P63 Or "Dual Lift Assist Wheel Package And Wing Down Flex Cylinder Package Hydraulic System", Page P64
2.		-	See "Wing Down Flex Cylinder", Page P69
3.		-	See "Wing Assembly", Pages P28 And P29
4.	GD10486	1	Pin, 1 1/4" x 9"
	G10460	2	Cotter Pin, 1/4" x 2"

CENTER SECTION GAUGE WHEEL

PLA029/PLA028/HTA014/PLA05(SFP10a)

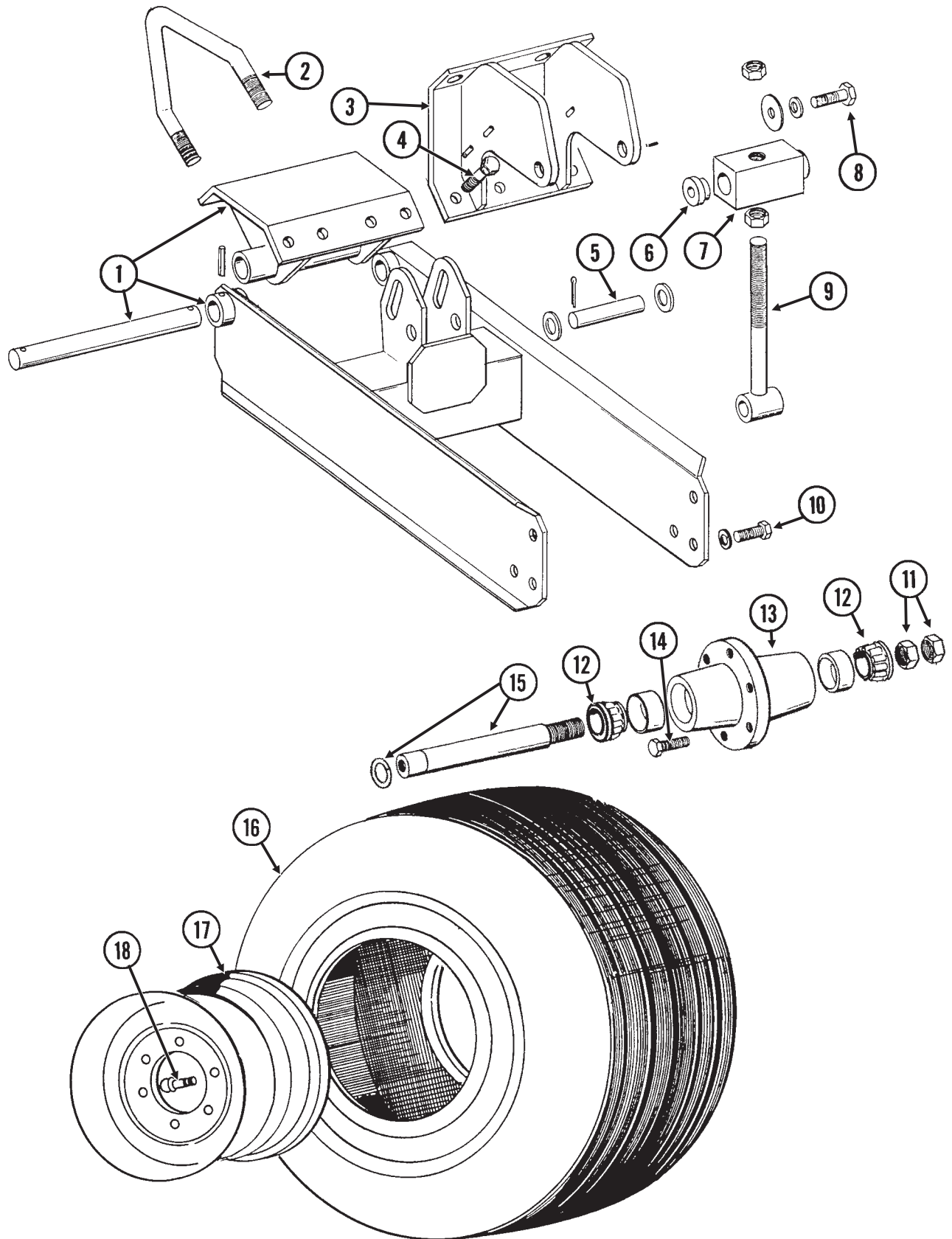

CENTER SECTION GAUGE WHEEL

ITEM	PART NO.	QTY.	DESCRIPTION
		(Per Assy.)	
1.	GA7294	1	Arm W/Shaft, Lower Clamp And Spring Pins
	GD5804	1	Shaft, 1 ¼" x 12"
	GA7295	1	Clamp W/ Grease Fittings
	G10641	-	Grease Fitting, ⅛" NPT
	G10610	-	Spring Pin, ⅜" x 2"
2.	GD8175	2	U-Bolt, 7" x 7" (Diamond) x ⅝"-11
	GD7805	4	Special Washer
	G10230	4	Lock Washer, ⅝"
	G10104	4	Hex Nut, ⅝"-11
3.	GA7322	1	Upper Clamp
4.	G10005	4	Hex Head Cap Screw, ⅝"-11 x 1 ¾"
	GD7805	4	Special Washer
	G10230	4	Lock Washer, ⅝"
	G10104	4	Hex Nut, ⅝"-11
5.	GD7041	1	Pin, 1" x 4"
	G10082	2	Washer, 1" SAE
	G10459	2	Cotter Pin, ⅜" x 1 ½"
6.	GD10403	2	Concentric Spacer
7.	GD10328	1	Adjustment Block
8.	G10026	2	Hex Head Cap Screw, ¾"-10 x 2"
	G10194	2	Washer, ¾" SAE
	G10231	2	Lock Washer, ¾"-10
9.	GA4705	1	Adjustment Screw
	G10117	2	Hex Nut, 1"-8
10.	G10026	2	Hex Head Cap Screw, ¾"-10 x 2"
	G10231	2	Lock Washer, ¾"
11.	G10087	-	Jam Nut, 1 ½"-10, Grade 2
12.	GA0895	2	Bearing
13.	GA2148	1	Hub W/Cups, 6 Bolt
	GR0434	-	Cup
14.	GR0270	6	Bolt, ⅞"-18
15.	GA2558	1	Spindle W/Round External Retaining Ring, 9 ½"
	GD11490	-	Round External Retaining Ring
16.	GD0844	1	Tire, 7.60" x 15", 4 Ply (Specify Brand*)
17.	GA5196	1	Wheel W/Valve Protector, 5" x 15"
18.	GD1166	1	Valve Stem
A.	GA2147	-	Hub Assembly (Items 10 And 11-15)
B.	GA7447	-	Center Section Gauge Wheel Assembly (Items 1-18)

* Specific brand requests will be supplied only as available from current KINZE® stock. If a specific brand as requested is not on hand, the brand available will be supplied.

DUAL LIFT ASSIST WHEELS

PLA031/PLA030/CCU008/HTA014/PLA05(SFP11d/MT23)

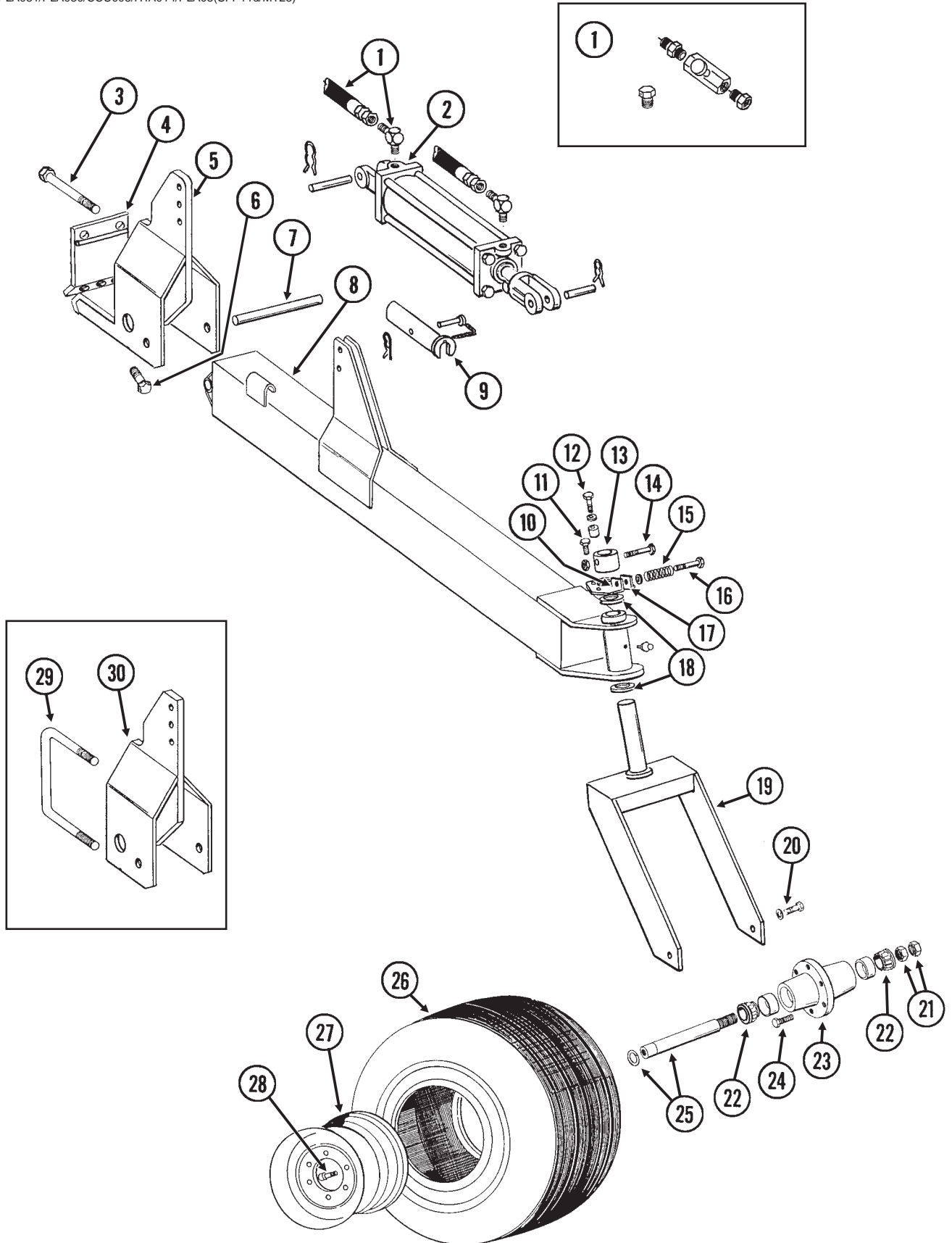

DUAL LIFT ASSIST WHEELS

ITEM	PART NO.	QTY.	DESCRIPTION
		(Per Assy.)	
1.		-	See "Dual Lift Assist Wheel Package Hydraulic System", Page P63 Or "Dual Lift Assist Wheel Package And Wing Down Flex Cylinder Package Hydraulic System", Page P64
2.		-	See "Dual Lift Assist Cylinder", Pages P70 And P71
3.	G10059	2	Hex Head Cap Screw, 3/4"-10 x 9 1/2"
	GD2169	2	Hardened Washer
	G10105	2	Hex Nut, 3/4"-10
4.	GA7867	-	Clamp
5.	GA7860	-	Mount
6.	G10028	3	Hex Head Cap Screw, 3/4"-10 x 3"
	GD2169	3	Hardened Washer
	G10105	3	Hex Nut, 3/4"-10
7.	GD8311	2	Pin, 1 1/4" x 10 1/2"
	G10460	4	Cotter Pin, 1/4" x 2"
8.	GA7345	1	Lift Assist Frame W/Grease Fittings
	G10641	1	Grease Fitting, 1/8" NPT
	G10343	1	Grease Fitting, 90°
9.	GA8174	1	Lockup W/Pin
10.	GA6455	1	Roller Ring, L.H.
11.	G10008	2	Hex Head Cap Screw, 5/8"-11 x 2"
	GB0218	2	Bushing, 1 9/32"
	GD7805	4	Special Washer
	G10230	2	Lock Washer, 5/8"
	G10104	2	Hex Nut, 5/8"-11
12.	G10007	2	Hex Head Cap Screw, 5/8"-11 x 1 1/2"
	GB0218	2	Bushing
	GD7805	4	Special Washer
	G10230	2	Lock Washer, 5/8"
	GD9179	2	Sleeve
13.	GD9170	1	Roller
14.	G10032	1	Hex Head Cap Screw, 1/2"-13 x 3 3/4"
	G10228	1	Lock Washer, 1/2"
	G10102	1	Hex Nut, 1/2"-13
15.	GD9208	1	Spring
16.	G10713	1	Hex Head Cap Screw, 7/16"-14 x 6"
	G10081	2	Washer, 7/16" USS
	G10113	1	Lock Nut, 7/16"-14
17.	GA6454	1	Roller Ring, R.H.
18.	G10234	2	Bushing, 10 Gauge
19.	GA6443	1	Caster Wheel
20.	G10026	2	Hex Head Cap Screw, 3/4"-10 x 2"
	G10231	2	Lock Washer, 3/4"
21.	G10087	2	Jam Nut, 1 1/2", Grade 2
22.	GA0895	2	Bearing
23.	GA2148	1	Hub W/Cups, 6 Bolt
	GR0434	-	Cup
24.	GR0270	6	Bolt, 9/16"-18
25.	GA2558	1	Spindle W/Round External Retaining Ring, 9 1/2"
	GD11490	-	Round External Retaining Ring
26.	GD0844	1	Tire, 7.60" x 15", 4 Ply (Specify Brand*)
27.	GA5196	1	Wheel W/Valve Protector, 5" x 15"
28.	GD1166	1	Valve Stem
29.	GD1748	2	U-Bolt, 7" x 7" x 3/4"-10
	G10231	4	Lock Washer, 3/4"
	G10105	4	Hex Nut, 3/4"-10
30.	GA7343	1	Mount
	G10641	-	Grease Fitting, 1/8" NPT
A.	GA2147	-	Hub Assembly (Items 4, 5, 20, 22, 24 And 25)

* Specific brand requests will be supplied only as available from current KINZE® stock. If a specific brand as requested is not on hand, the brand available will be supplied.

TRANSMISSION AND MODULE DRIVE ASSEMBLY

PTD085/PTD084/PLA027/PTD082(SFP24a)

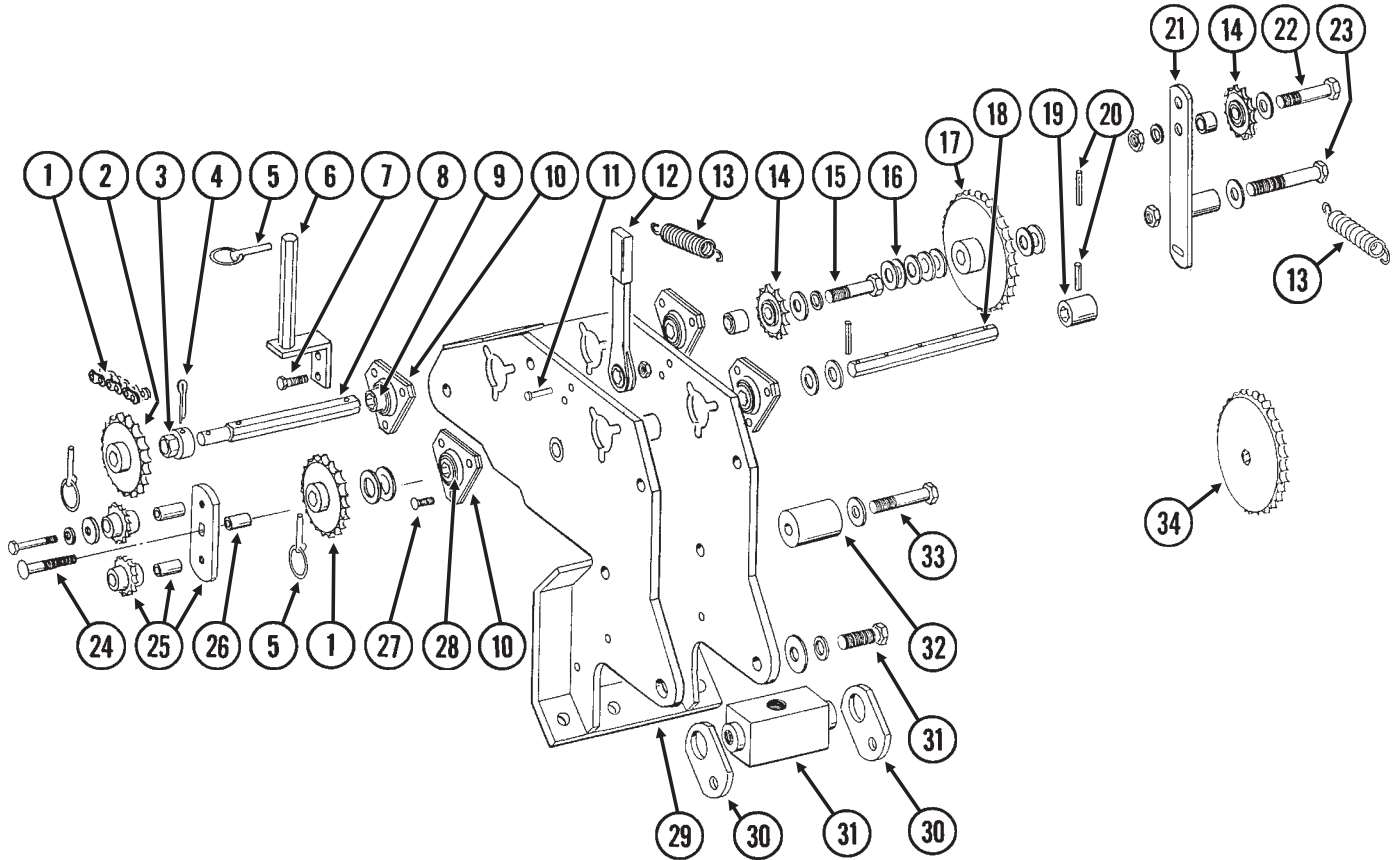

NOTE: See "Module Drive", Pages P40 And P41 For Wing Drill Shafts.

ITEM	PART NO.	QTY.	DESCRIPTION
		(Per Assy.)	
1.	G3310-68	1	Chain, No. 40, 68 Pitch Including Connector Link
	GR0912	-	Connector Link, No. 40
2.	GA5106	1	Sprocket, 17 Tooth
	GA5107	1	Sprocket, 19 Tooth
	GA5108	2	Sprocket, 23 Tooth
	GA5109	1	Sprocket, 24 Tooth
	GA5110	1	Sprocket, 25 Tooth
	GA5111	1	Sprocket, 26 Tooth
	GA5112	1	Sprocket, 27 Tooth
	GA5113	1	Sprocket, 28 Tooth
3.	GD7127	1	Shear Coupler
4.	G10462	1	Cotter Pin, 3/16" x 2"
5.	GD2558	3	Lynch Pin, 1/4"
6.	GA4630	1	Sprocket Storage Rod

TRANSMISSION AND MODULE DRIVE ASSEMBLY

ITEM	PART NO.	QTY.	DESCRIPTION
		(Per Assy.)	
7.	G10037	1	Hex Head Cap Screw, 1/2"-13 x 1 1/4"
	G10228	1	Lock Washer, 1/2"
	G10102	1	Hex Nut, 1/2"-13
8.	GD10336	1	Shaft, 7/8" x 11"
9.	GA5548	1	Special Spherical Bearing
10.	G3400-01	4	Flangette
11.	G10478	1	Clevis Pin, 5/16" x 1"
	G10409	1	Ring
12.	GA4235	1	Ratchet Wrench W/Protective Closure
	G10445	-	Protective Closure
13.	GD5857	3	Spring
14.	GA7154	3	Sprocket W/Bearing, 18 Tooth
15.	G10397	1	Hex Head Cap Screw, 1/2"-13 x 2 3/4"
	G10128	1	Bushing
	GB0258	1	Spacer, 7/8"
	G10228	1	Lock Washer, 1/2"
	G10102	1	Hex Nut, 1/2"-14
16.	G10233	-	Machine Bushing (As Required)
17.	GA5202	1	Sprocket, 34 Tooth, See "Point Row Wrap Spring Clutch" For Machines Equipped With Point Row Clutches
18.	GD10337	1	Shaft, 7/8" x 10 1/2"
19.		-	See "Center Drop Assembly And Driveline", Pages P52 And P53
20.	G10602	7	Spring Pin, 1/4" x 1 1/2"
21.	GA6533	2	Idler Arm
22.	G10581	2	Hex Head Cap Screw, 1/2"-13 x 2 1/4"
	G10128	2	Machine Bushing
	GD7889	2	Bushing
	G10228	2	Lock Washer, 1/2"
	G10102	2	Hex Nut, 1/2"-13
23.	G10013	1	Hex Head Cap Screw, 5/8"-11 x 3 1/2"
	GD5805	1	Special Washer
	G10503	1	Jam Nut, 5/8"-11
	G10107	1	Lock Nut, 5/8"-11
24.	G10863	1	Carriage Bolt, 1/2"-13 x 2 3/4"
	G10111	1	Lock Nut, 1/2"-13
25.	GA7336	1	Idler W/Bolt-On Sprockets
	GD7426	-	Sprocket
	GD1026	-	Spacer, 1 3/16"
	G10210	-	Washer, 3/8" USS
	G10229	-	Lock Washer, 3/8"
	G10047	-	Hex Head Cap Screw, 3/8"-16 x 1 3/4"
26.	GD3180-05	1	Sleeve, 1 3/16"
27.	G10303	12	Carriage Bolt, 5/16"-18 x 1"
	G10232	12	Lock Washer, 5/16"
	G10106	12	Hex Nut, 5/16"-18
28.	G2100-03	2	Bearing, 7/8" Hex Bore, Spherical
29.	GA7298	1	Module
30.	GD5792	2	Strap
31.		-	See "Ground Drive Wheel Assembly", Pages P30 And P31
32.	GD10407	1	Chain Support
33.	G10033	1	Hex Head Cap Screw, 1/2"-13 x 3 1/2"
	G10206	1	Washer, 1/2" SAE
	G10228	1	Lock Washer, 1/2"
	G10102	1	Hex Nut, 1/2"-13
34.		-	See "Contact Drive Wheel Assembly", Page P32

MODULE DRIVE

ITEM	PART NO.	QTY. (Per Assy.)	DESCRIPTION
1.		-	See "Transmission And Module Drive Assembly", Pages P38 And P39
2.	GD5860	1	Bar
3.	G10064	1	Hex Head Cap Screw, 1/4"-20 x 1"
	G10227	1	Lock Washer, 1/4"
	G10103	1	Hex Nut, 1/4"-20
4.	GD5857	3	Spring
5.	G10069	1	Hex Head Cap Screw, 5/16"-18 x 2 1/4"
	G10219	1	Washer, 5/16" USS
	G10106	1	Hex Nut, 5/16"-18
6.	G10582	1	Hex Adjustment Bolt, 5/8"-11 x 4"
	GD7805	1	Special Washer
	GD3180-15	1	Sleeve, 15/32"
	G10104	1	Hex Nut, 5/8"-11
	G10205	1	Washer, 5/8" SAE
	G10107	1	Lock Nut, 5/8"-11
7.	GA5105	1	Sprocket, 15 Tooth
8.	GA6533	2	Idler Arm
9.	GA5114	1	Sprocket, 30 Tooth
10.	G3310-75	1	Chain, No. 40, 75 Pitch Including Connector Link And Offset Link
	GR0912	-	Connector Link, No. 40
	GR0911	-	Offset Link, No. 40
11.	GD0917	-	Lock Collar, 7/8" Hex, Less Set Screws (Sub G1K269)
	G10145	-	Set Screw, 5/16"-18 x 1/2"
12.	GA2180	2	Hanger Bearing
13.	G10233	-	Machine Bushing (As Required)
14.	GD0914-74	1	Wing Drill Shaft, 8 Row 38"/40" And 12 Row 30"
	GD0914-98	-	Wing Drill Shaft, 12 Row 36"/38"/40" And 16 Row 30"
15.	G10004	2	Hex Head Cap Screw, 3/8"-16 x 1 1/4"
	G10210	2	Washer, 3/8" USS
	G10229	2	Lock Washer, 3/8"
	G10101	2	Hex Nut, 3/8"-16
16.	G10581	2	Hex Head Cap Screw, 1/2"-13 x 2 1/4"
	G10128	2	Machine Bushing
	GD7889	2	Bushing
	G10228	2	Lock Washer, 1/2"
	G10102	2	Hex Nut, 1/2"-13
17.	GA7154	3	Sprocket W/Bearing, 18 Tooth
18.	G10602	7	Spring Pin, 1/4" x 1 1/2"
19.	G10233	-	Machine Bushing
20.	GD11045	-	Lock Clamp
21.	G10031	-	Hex Head Cap Screw, 5/16"-18 x 1 3/4"
A.	G1K269	-	Lock Clamp Kit (Items 20 And 21)

POINT ROW WRAP SPRING CLUTCH

PRC019/PRC020(PLTR128/SFP5b)

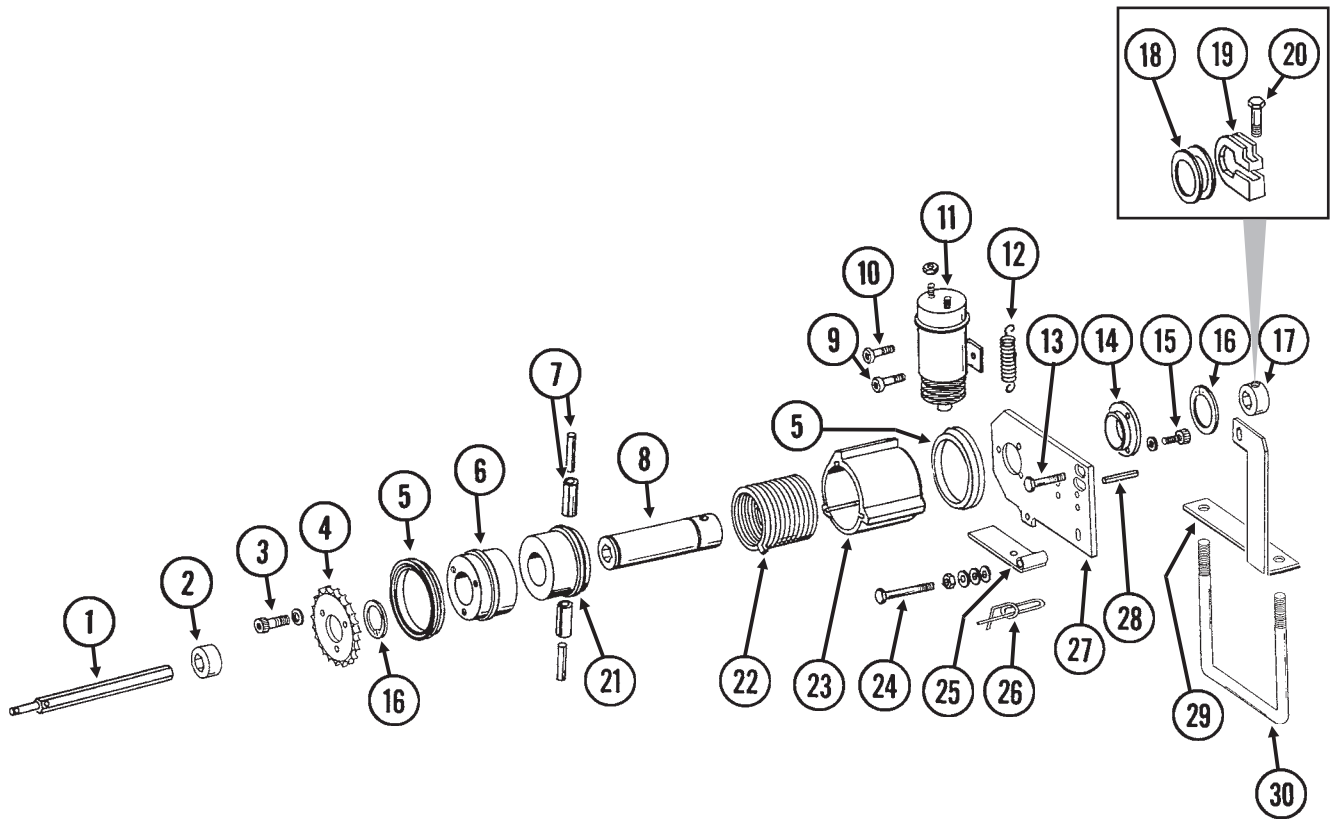

POINT ROW WRAP SPRING CLUTCH

ITEM	PART NO.	QTY. (Per Assy.)	DESCRIPTION
1.	GD10527	1	Input Shaft, 7/8" x 15 1/2"
2.	GD10200	1	Spacer, 3/4"
3.	G10023	3	Hex Head Cap Screw, 1/4"-20 x 3/4"
	G10227	3	Lock Washer, 1/4"
4.	GD10525	1	Sprocket, 34 Tooth
5.	GD10120	2	Seal
6.	GD10104	1	Input Hub
7.	G10804	2	Spring Pin, 5/32" x 7/8"
	G10765	2	Spring Pin, 1/4" x 1"
8.	GD10106	1	Sleeve
9.	G10900	1	Socket Head Cap Screw, 1/4"-20 x 1 3/4"
	G10227	1	Lock Washer, 1/4"
	G10103	2	Hex Nut, 1/4"-20
10.	G10023	1	Hex Head Cap Screw, 1/4"-20 x 3/4"
	G10227	1	Lock Washer, 1/4"
	G10103	1	Hex Nut, 1/4"-20
11.	GA8393	1	Solenoid Complete
	GR1306	1	Snap Ring
	GR1303	1	Spring
	GR1304	1	Boot
	GR1305	1	Plunger
12.	GD10123	1	Spring
13.	G10003	1	Hex Head Cap Screw, 3/8"-16 x 1 1/2"
	G10203	2	Washer, 3/8" SAE
	G10101	1	Hex Nut, 3/8"-16
14.	GD9667	1	Bushing
15.	G10253	3	Socket Head Screw, No. 10-32 x 1/2"
	G10257	3	Lock Washer, No. 10
16.	G10496	2	Snap Ring
17.	GD0917	1	Lock Collar, Less Set Screws (Sub G1K269)
	G10145	-	Set Screw, 5/16"-18 x 1/2"
18.	G10233	-	Machine Bushing
19.	GD11045	-	Lock Clamp
20.	G10031	-	Hex Head Cap Screw, 5/16"-18 x 1 3/4"
	G10620	-	Flange Nut, 5/16"-18
21.	GD10105	1	Output Hub
22.	GD9672	1	Spring, R.H. (L.H. Side Of Machine)
	GD9671	-	Spring, L.H. (R.H. Side Of Machine)
23.	GD10102	1	Stop Collar
24.	G10049	1	Hex Head Cap Screw, 3/8"-16 x 2 1/2"
	G10101	1	Hex Nut, 3/8"-16
	G10203	1	Washer, 3/8" SAE
	G10229	2	Lock Washer, 3/8"
	G10497	1	Hex Jam Nut, 3/8"-16
25.	GD10510	1	Actuator Arm
26.	GD11120	1	Rue Ring Cotter, 5/16"
27.	GD10103	1	Mounting Plate
28.	G10859	1	Spring Pin, 3/16" x 2 1/4"
29.	GD10529	1	Bracket, L.H. (Shown)
	GD10528	-	Bracket, R.H.
30.	GD7145	1	U-Bolt, 7" x 7" x 1/2"-13
	G10111	2	Lock Nut, 1/2"-13
A.	G1K269	-	Lock Clamp Kit (Items 19 And 20)

POINT ROW WRAP SPRING CLUTCH ELECTRICAL COMPONENTS

(EF10/EF10B/SFP6/TWL18)

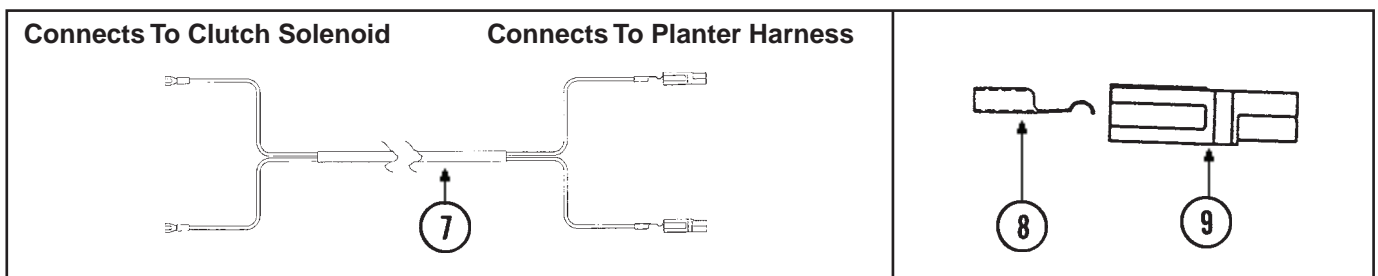
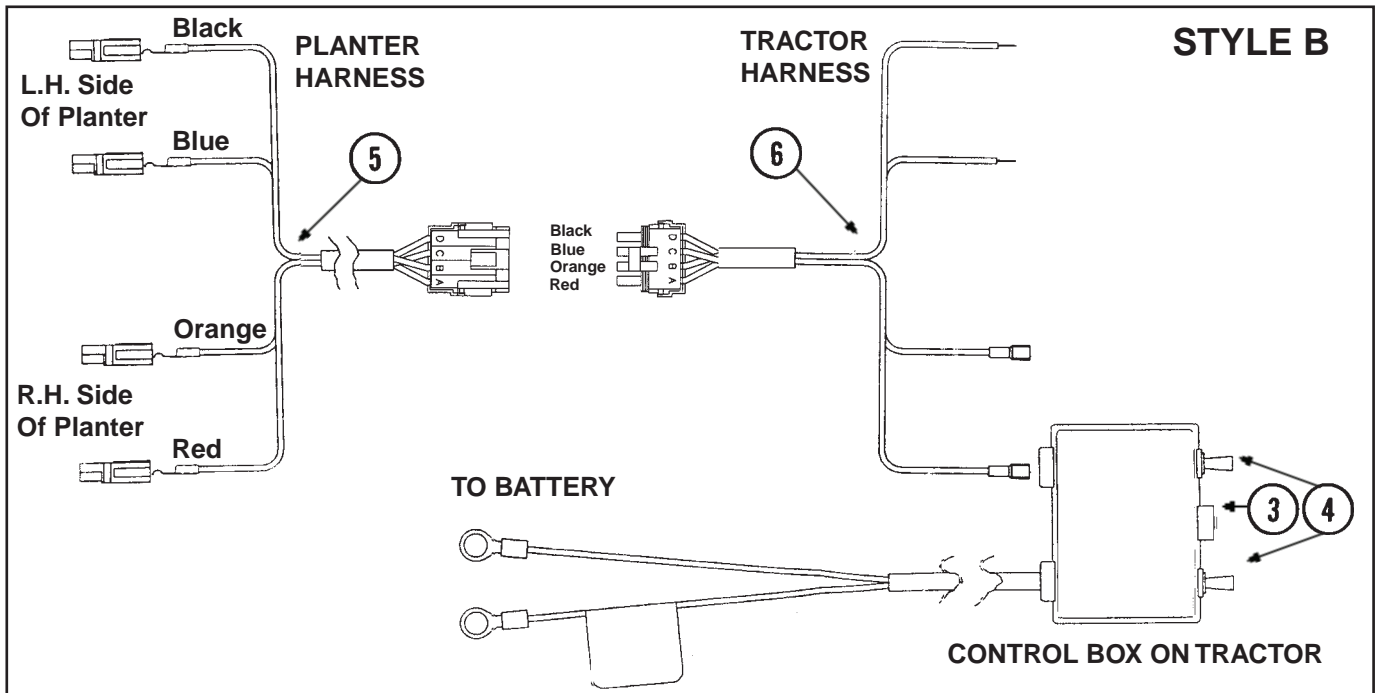
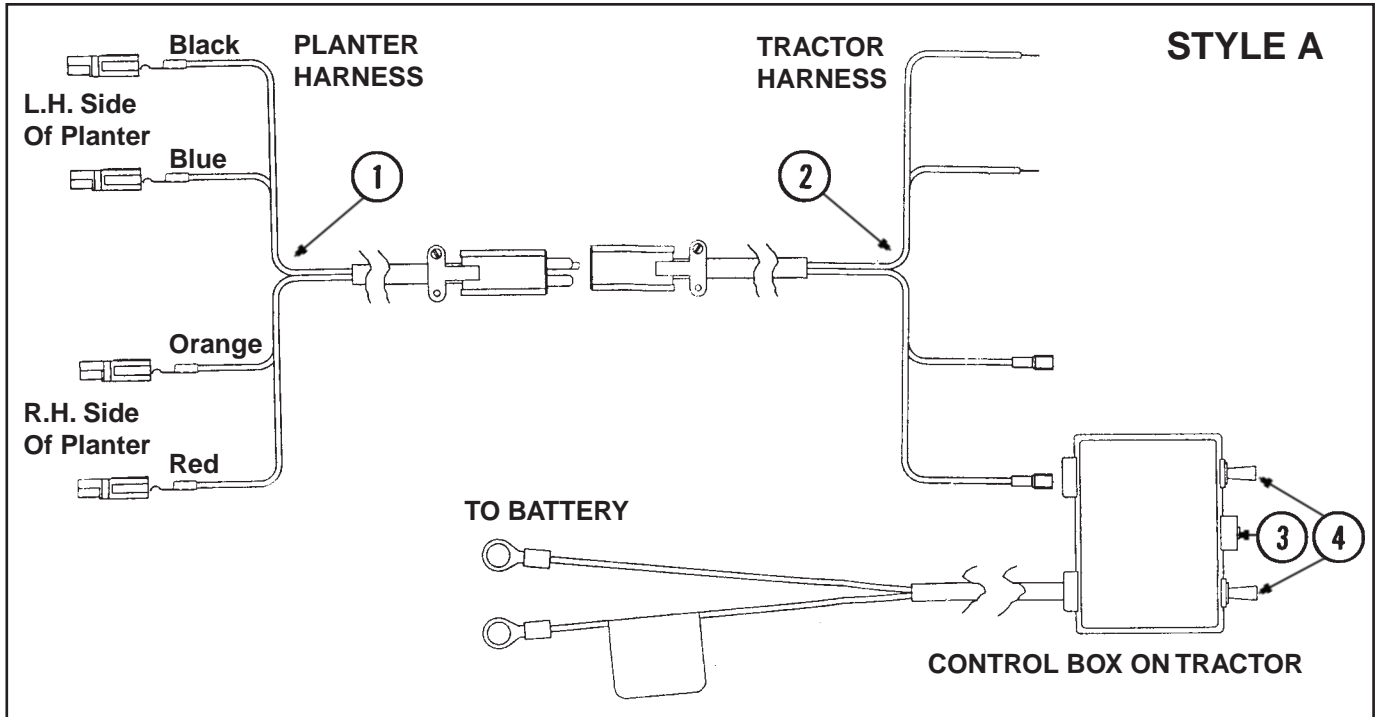

POINT ROW WRAP SPRING CLUTCH ELECTRICAL COMPONENTS

ITEM	PART NO.	QTY. (Per Assy.)	DESCRIPTION
1.	GR1355	-	Harness W/Plug Connector, 60"
	GR1346	-	Plug Connector
2.	GR1345	-	Harness W/Socket Connector, 152"
	GR1347	-	Socket Connector
3.	GA7165	-	Circuit Breaker, 12 Amp
4.	GA7144	-	Two Position Switch
5.	GR1450	-	Harness W/4 Pin Connector, 60"
	GA8328	-	Connector W/Housing, 4 Seals And 4 Pin Contacts
6.	GR1447	-	Harness W/4 Socket Connector, 152"
	GA8329	-	Connector W/Housing, 4 Seals And 4 Socket Contacts
7.	GA7416	1	Wiring Harness, 24'
8.	GD9530	-	Contact
9.	GD9529	-	Housing

TWO-SPEED POINT ROW WRAP SPRING CLUTCH

PRC023(SFP45a)

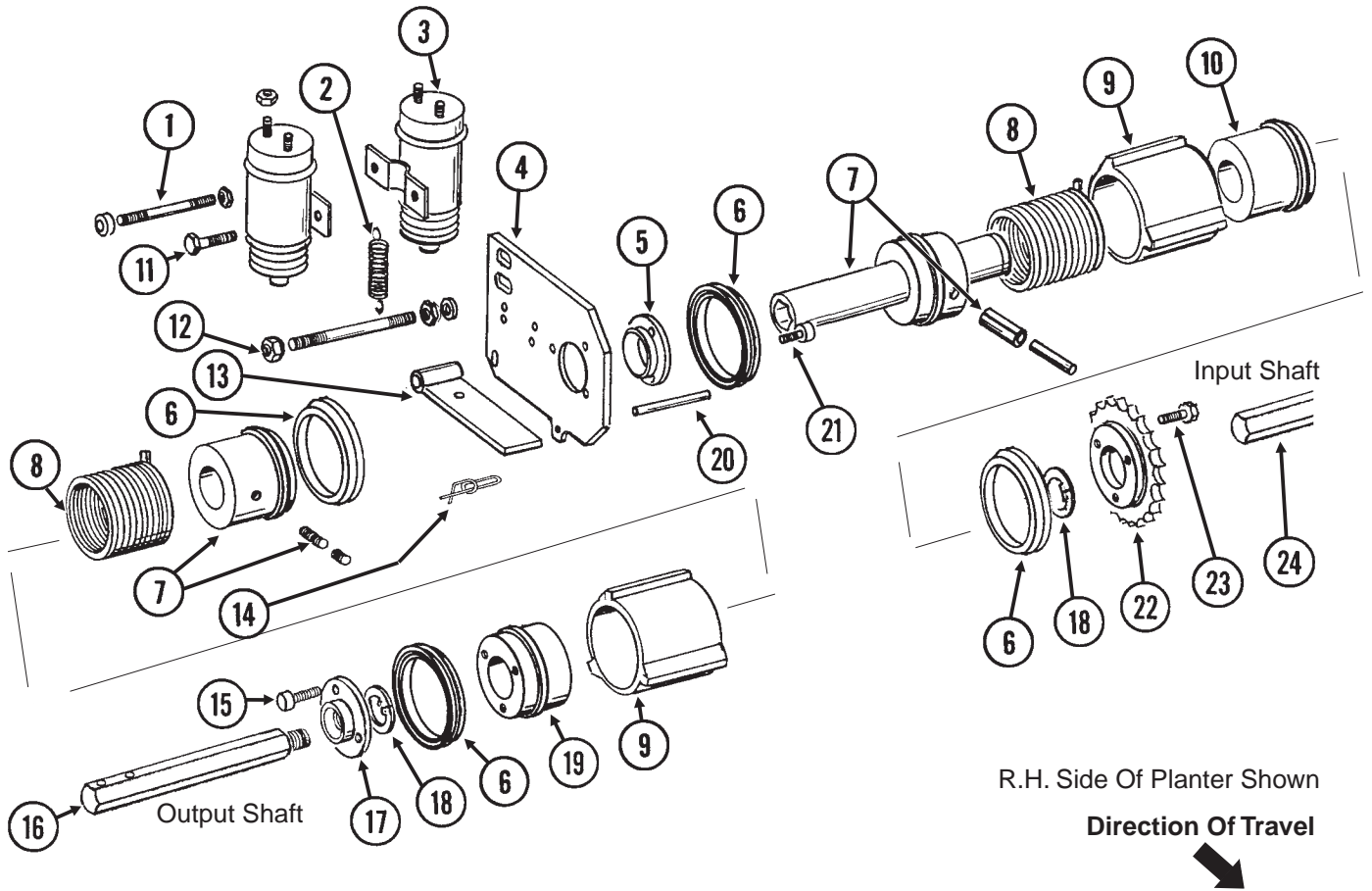

TWO-SPEED POINT ROW WRAP SPRING CLUTCH

ITEM	PART NO.	QTY. (Per Assy.)	DESCRIPTION
1.	GD10635	1	Threaded Rod, 1/4"-20 x 3 1/2"
	G10103	2	Hex Nut, 1/4"-20
	G10227	2	Lock Washer, 1/4"
	GD10282	2	Allen Nut, 1/4"-20
2.	GD10123	2	Spring
3.	GA8393	2	Solenoid Complete
	GR1306	-	Snap Ring
	GR1303	-	Spring
	GR1304	-	Boot
	GR1305	-	Plunger
4.	GD10103	1	Mounting Plate
5.	GD10586	1	Bushing
6.	GD10120	4	Seal
7.	GA7463	1	Hub/Sleeve Assembly W/Pins And Screws
	G10873	-	Hex Socket Set Screw, 5/16"-18 x 3/4"
	G10872	-	Hex Socket Set Screw, 5/16"-18 x 1/4"
	G10804	-	Spring Pin, 5/32" x 7/8"
	G10765	-	Spring Pin, 1/4" x 1"
8.	GD9672	2	Spring, R.H. (R.H. Side Of Machine)
	GD9671	-	Spring, L.H. (L.H. Side Of Machine)
9.	GD10585	2	Stop Collar
10.	GD10580	1	Drive Hub
11.	G10023	1	Hex Head Cap Screw, 1/4"-20 x 3/4"
	G10227	1	Lock Washer, 1/4"
	G10103	1	Hex Nut, 1/4"-20
12.	GD10636	1	Threaded Rod, 3/8"-16 x 4 1/4"
	G10108	2	Lock Nut, 3/8"-16
	G10229	2	Lock Washer, 3/8"
	G10101	2	Hex Nut, 3/8"-16
13.	GD10510	2	Actuator Arm
14.	GD11120	2	Rue Ring Cotter, 5/16"
15.	G10857	3	Hex Head Cap Screw, 1/4"-20 x 1 1/4"
	G10227	3	Lock Washer, 1/4"
16.	GD10694	1	Shaft, R.H. Thread (L.H. Side Of Planter)
	GD10693	-	Shaft, L.H. Thread (R.H. Side Of Planter)
17.	GD10638	1	Coupler W/R.H. Threads (L.H. Side Of Planter)
	GD10587	-	Coupler W/L.H. Threads (R.H. Side Of Planter)
18.	G10496	2	Snap Ring
19.	GD10583	1	Driven Hub
20.	G10859	1	Spring Pin, 3/16" x 2 1/4"
21.	G10876	3	Hex Socket Head Screw, No. 10-32 x 1/4"
22.	GD10673	1	Input Sprocket, 34 Tooth
23.	G10374	3	Hex Socket Head Screw, 1/4"-20 x 1"
24.	GD10698	1	Input Shaft, 7/8" x 17 1/2"

TWO-SPEED POINT ROW WRAP SPRING CLUTCH ELECTRICAL COMPONENTS

(SFP46/SFP46D/TWL71A/TWL76/TWL18)

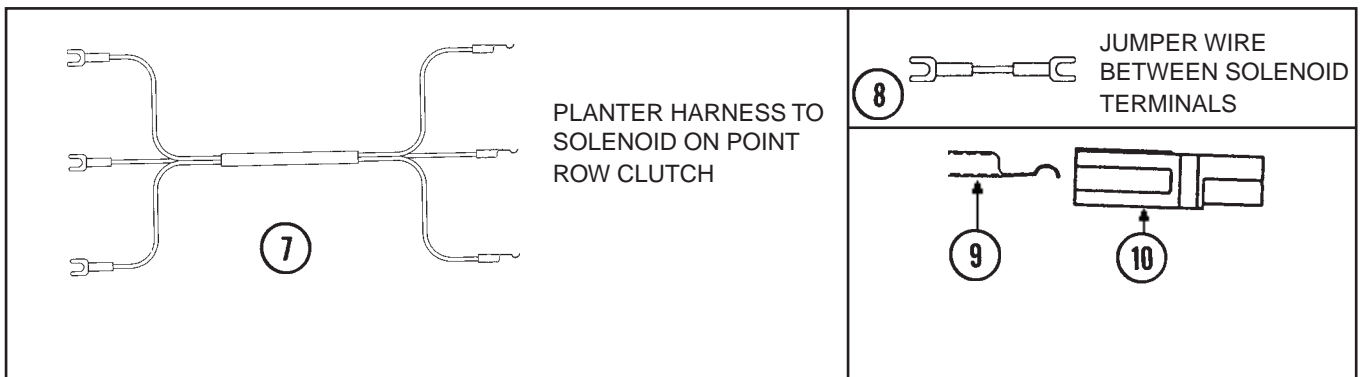
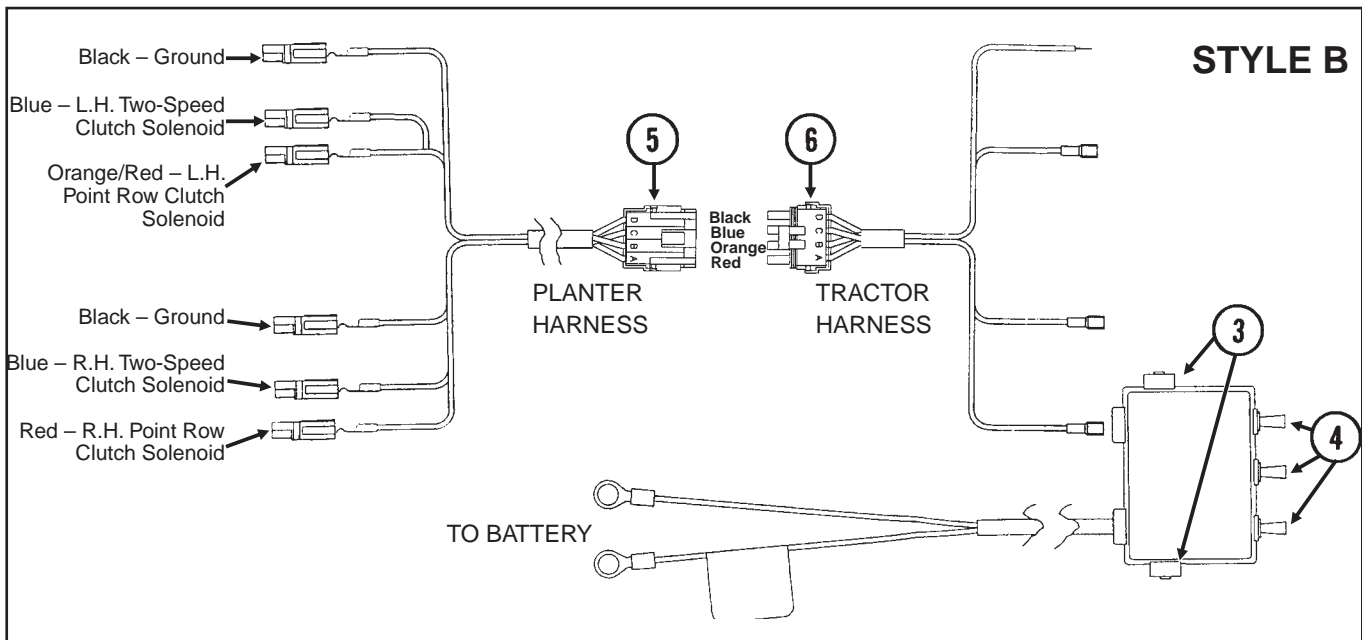
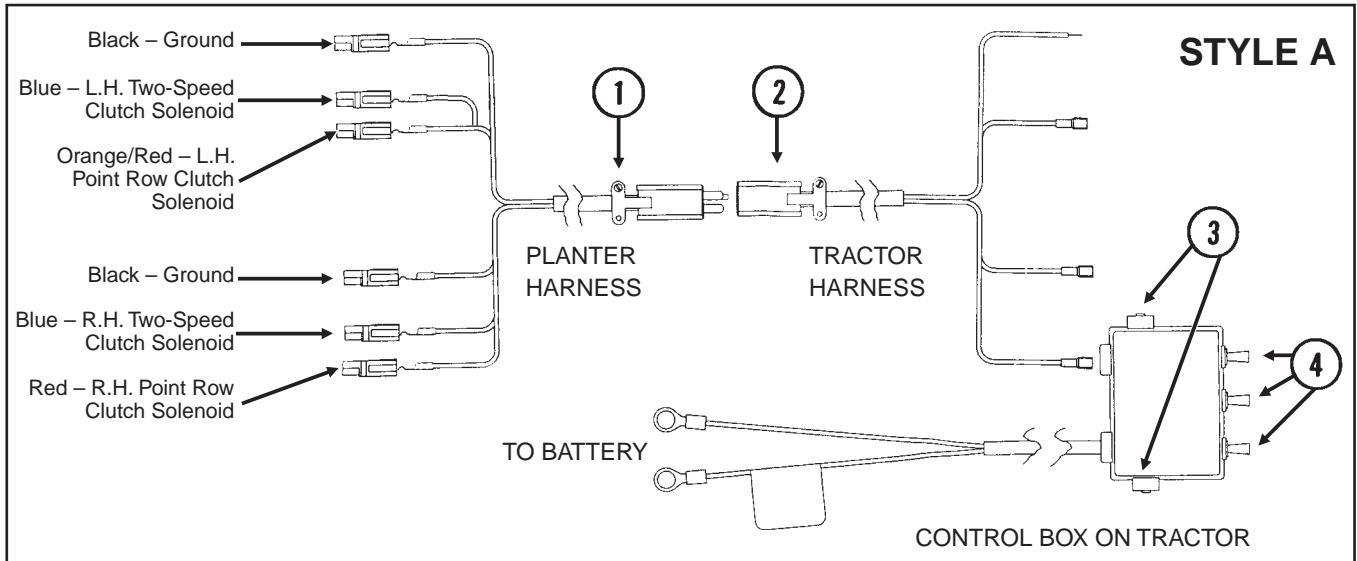

TWO-SPEED POINT ROW WRAP SPRING CLUTCH ELECTRICAL COMPONENTS

ITEM	PART NO.	QTY. (Per Assy.)	DESCRIPTION
1.	GR1362	-	Harness W/Plug Conenctor, 60"
	GR1346	-	Plug Connector
2.	GR1361	-	Harness W/Socket Connector, 152"
	GR1347	-	Socket Connector
3.	GA7165	2	Circuit Breaker
4.	GA7144	3	Two Position 12 Amp Switch
5.	GR1448	-	Harness W/4 Pin Connector, 60"
	GA8328	-	Connector W/Housing, 4 Seals And 4 Pin Contacts
6.	GR1449	-	Harness W/4 Socket Connector, 152"
	GA8329	-	Connector W/Housing, 4 Seals And 4 Socket Contacts
7.	GA7577	1	Wiring Harness, 24'
8.	GA7274	1	Jumper Wire, Between Solenoids
9.	GD9530	-	Contact
10.	GD9529	-	Housing

TWO-SPEED POINT ROW WRAP SPRING CLUTCH TRANSMISSION AND MODULE DRIVE

PTD085/PTD084/PLA027/PTD082(SFP44/FF49/PLTR128)

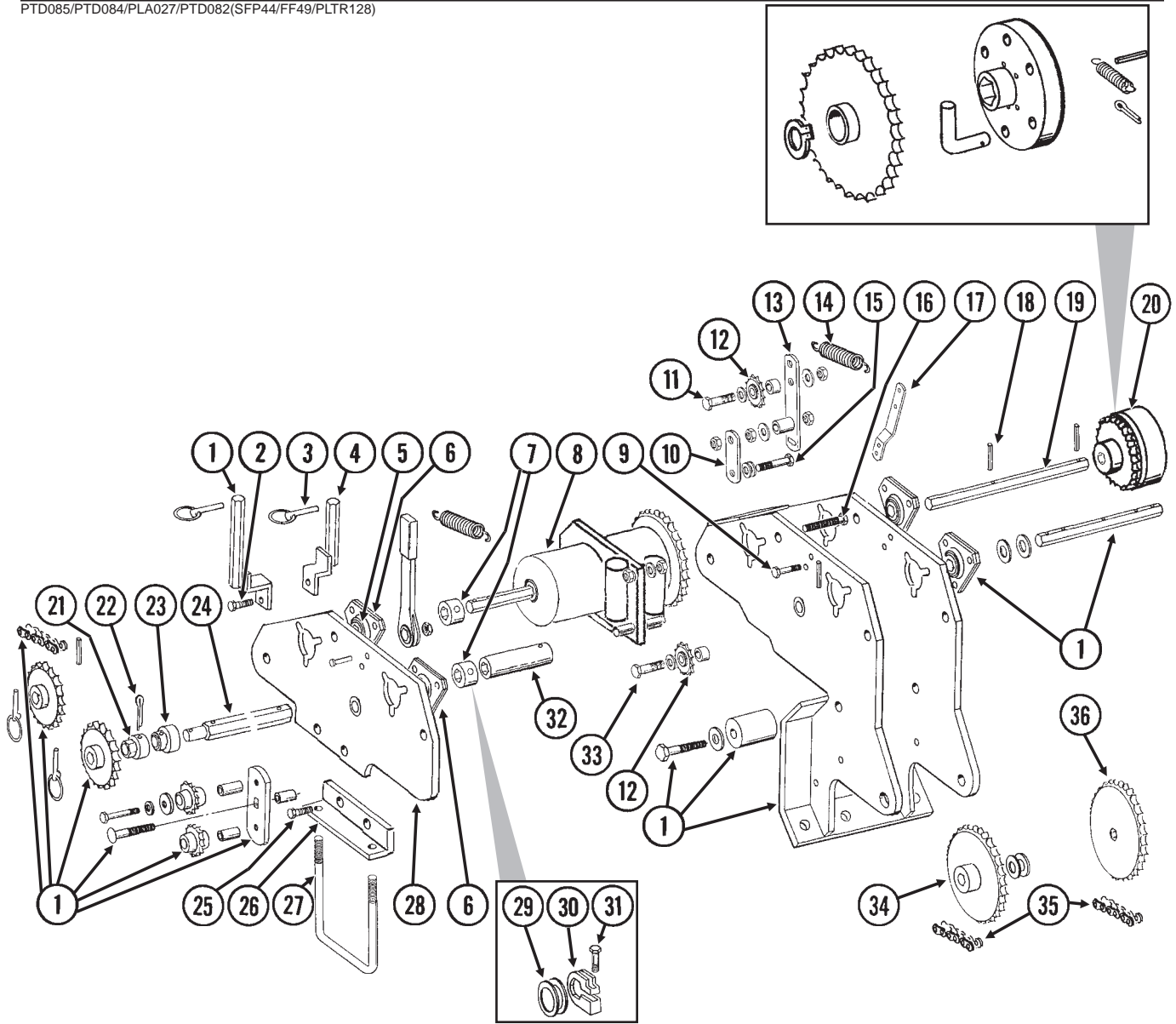

ITEM	PART NO.	QTY. (Per Assy.)	DESCRIPTION
1.		-	See "Transmission And Module Drive Assembly", Pages P38 And P39
2.	G10017	1	Hex Head Cap Screw, 1/2"-13 x 1 1/2"
	G10228	1	Lock Washer, 1/2"
	G10102	1	Hex Nut, 1/2"-13
3.	GD2558	2	Lynch Pin, 1/4"
4.	GA7313	1	Sprocket Storage Rod
5.	G2100-03	1	Bearing, 7/8" Hex Bore, Spherical
6.	G3400-01	4	Flangette
7.	GD0917	2	Lock Collar, 7/8" Hex, Less Set Screws (Sub G1K269)
	G10145	-	Set Screws, 5/16"-18 x 1/2"
8.		-	See "Two-Speed Point Row Wrap Spring Clutch", Pages P46 And P47
9.	G10064	2	Hex Head Cap Screw, 1/4"-20 x 1"
	G10227	2	Lock Washer, 1/4"
	G10103	2	Hex Nut, 1/4"-20
10.	GD10697	1	Bracket

TWO-SPEED POINT ROW WRAP SPRING CLUTCH TRANSMISSION AND MODULE DRIVE

ITEM	PART NO.	QTY. (Per Assy.)	DESCRIPTION
11.	G10581	1	Hex Head Cap Screw, 1/2"-13 x 2 1/4"
	G10128	1	Machine Bushing
	GD7889	1	Bushing
	G10228	1	Lock Washer, 1/2"
	G10102	1	Hex Nut, 1/2"-13
12.	GA7154	2	Sprocket W/Bearing, 18 Tooth
13.	GA6533	1	Idler Arm
14.	GD5857	1	Spring
15.	G10062	1	Hex Head Cap Screw, 3/8"-16 x 3"
	G10203	4	Washer, 3/8" SAE
	G10101	2	Hex Nut, 3/8"-16
16.	G10582	1	Full Thread Bolt, 5/8"-11 x 4"
	GD7805	1	Special Washer
	G10503	3	Hex Jam Nut, 5/8"-11
17.	GD5860	1	Spring Mount Bar
18.	G10602	-	Spring Pin, 1/4" x 1 1/2"
19.	GD10698	1	Shaft, 7/8" x 17 1/2"
20.	A7550	1	Overrunning Sprocket Assembly, R.H. (Non-Stock Item)
	A7549	-	Overrunning Sprocket Assembly, L.H. (Non-Stock Item)
	G10430	1	Ring
	GD1255	6	"L" Pin
	G10546	6	Spring Pin, 3/16" x 1 1/4"
	G10470	6	Cotter Pin, 5/32" x 1"
	GD10366	6	Spring
	GA7317	1	Block
	GA7574	1	Sprocket W/Bushing, 34 Tooth
21.	GD7127	1	Shear Coupler
22.	G10462	1	Cotter Pin, 3/16" x 2"
23.	GA5548	1	Special Extended Spherical Bearing
24.	GD10336	1	Shaft, 7/8" x 11"
25.	G10007	1	Hex Head Cap Screw, 5/8"-11 x 1 1/2"
	G10205	1	Washer, 5/8" SAE
	G10230	1	Lock Washer, 5/8"
	G10104	1	Hex Nut, 5/8"-11
26.	GD10696	1	Mounting Angle
27.	GD1114	1	U-Bolt, 7" x 7" x 5/8"-11
	G10230	2	Lock Washer, 5/8"
	G10104	2	Hex Nut, 5/8"-11
28.	GA7571	1	Transmission Bracket, L.H. (Shown)
	GA7570	-	Transmission Bracket, R.H.
29.	G10233	-	Machine Bushing
30.	GD11045	2	Lock Clamp
31.	G10031	2	Hex Head Cap Screw, 5/16"-18 x 1 3/4"
	G10620	2	Flange Nut, 5/16"-18
32.	GD10109	1	Coupler, 6"
33.	G10397	1	Hex Head Cap Screw, 1/2"-13 x 2 3/4"
	G10128	1	Bushing
	GB0258	1	Stepped Spacer
	G10228	1	Lock Washer, 1/2"
	G10102	1	Hex Nut, 1/2"-13
34.	GA5114	1	Sprocket, 30 Tooth
35.	G3310-224	2	Chain, No. 40, 224 Pitch Including Connector Link
	GR0912	-	Connector Link, No. 40
36.	GA5109	1	Sprocket, 24 Tooth
	GA5105	1	Sprocket, 15 Tooth
	GA5106	1	Sprocket, 17 Tooth
	GA5112	1	Sprocket, 27 Tooth
	GA5108	-	Sprocket, 23 Tooth (From Transmission)
	GA5110	-	Sprocket, 25 Tooth (From Transmission)
	GA5111	-	Sprocket, 26 Tooth (From Transmission)
A.	G1K269	-	Lock Clamp Kit (Items 30 And 31)

CENTER DROP ASSEMBLY AND DRIVELINE

PTD081/PTD080/PTD077/PFA052/PTD016(SFP23d/SFP22/PT6)

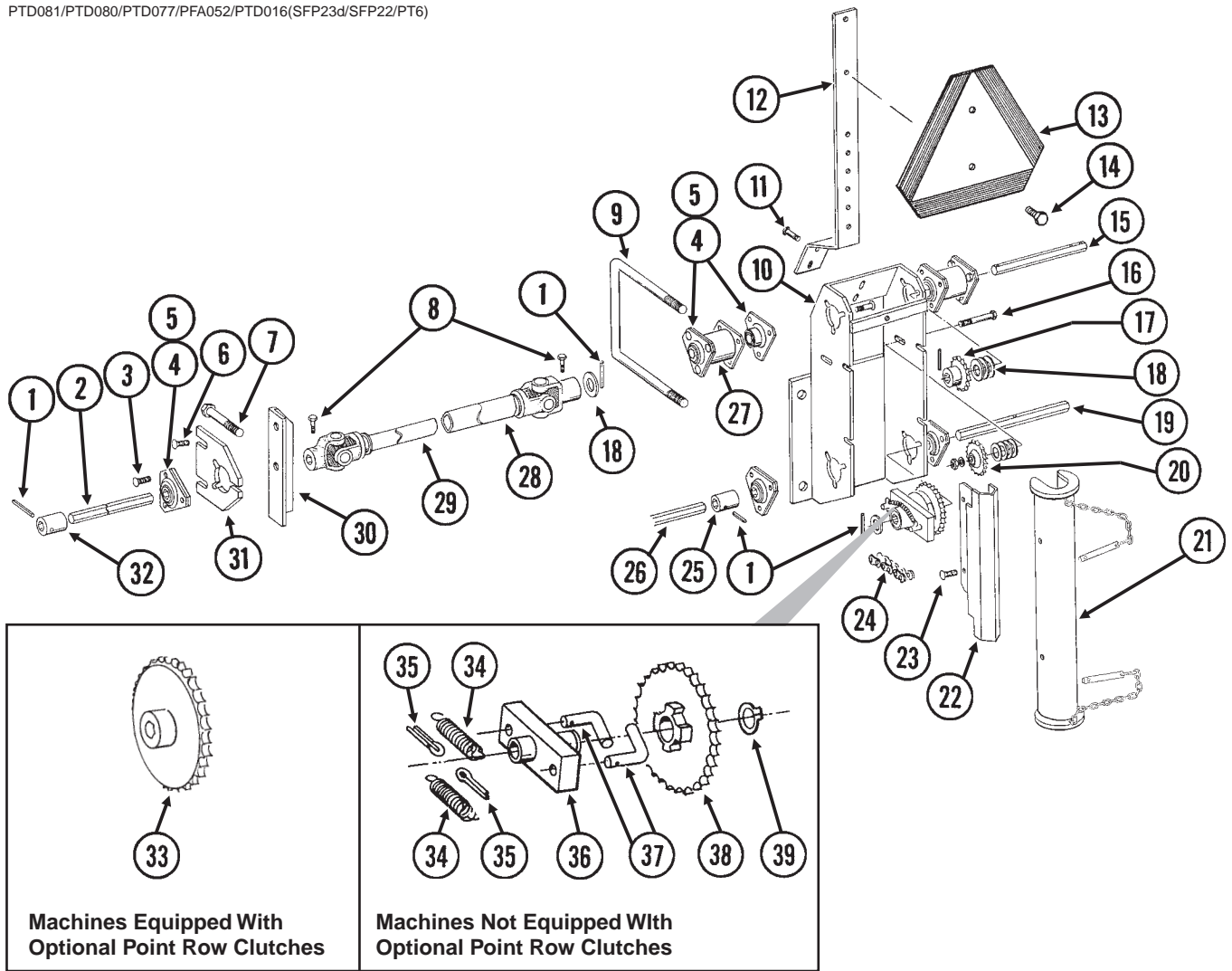

ITEM	PART NO.	QTY.	DESCRIPTION
1.	G10602	5	Spring Pin, 1/4" x 1 1/2"
2.	GD2548-58	2	Drive Shaft, 7/8" Hex, 8 Row 38"/40" And 12 Row 30"
	GD2548-60	-	Drive Shaft, 7/8" Hex, 12 Row 36"/38"
	GD2548-70	-	Drive Shaft, 7/8" Hex, 12 Row 38"/40"
	GD2548-90	-	Drive Shaft, 7/8" Hex, 16 Row 30"
3.	G10303	18	Carriage Bolt, 5/16"-18 x 1"
	G10232	18	Lock Washer, 5/16"
	G10106	18	Hex Nut, 5/16"-18
4.	G2100-03	8	Bearing, 7/8" Hex Bore, Spherical
5.	G3400-01	12	Flangette
6.	G10574	4	Carriage Bolt, 1/2"-13 x 1 1/4"
	G10228	4	Lock Washer, 1/2"
	G10102	4	Hex Nut, 1/2"-13
7.	G10017	4	Hex Head Cap Screw, 1/2"-13 x 1 1/2"
	G10216	4	Washer, 1/2" USS
	G10228	4	Lock Washer, 1/2"
	G10101	4	Hex Nut, 1/2"-13
8.	G10880	4	Hex Head Cap Screw, 1/4"- 20 x 2 1/4"
	G10110	4	Lock Nut, 1/4"-20
9.	GD1114	2	U-Bolt, 7" x 7" x 5/8"-11
	G10230	4	Lock Washer, 5/8"
	G10104	4	Hex Nut, 5/8"-11

CENTER DROP ASSEMBLY AND DRIVELINE

ITEM	PART NO.	QTY.	DESCRIPTION
10.	GA7301	1	Transfer Case
11.	G10001	2	Hex Head Cap Screw, 3/8"-16 x 1"
	G10229	2	Lock Washer, 3/8"
	G10101	2	Hex Nut, 3/8"-16
12.	GD10454	1	SMV/Bulkhead Mount, 8 Row 38"/40" And 12 Row 30"
	GD10507	-	SMV/Bulkhead Mount, 12 Row 36"/38"/40" And 16 Row 30"
13.	GD2199	1	SMV Sign
14.	G10023	2	Hex Head Cap Screw, 1/4"-20 x 3/4"
	G10112	2	Lock Nut, 1/4"-20
15.	GD10348	2	Top Shaft, 7/8" x 7 1/2"
16.	G10581	2	Hex Head Cap Screw, 1/2"-13 x 2 1/4"
	G10206	12	Washer, 1/2" SAE
	G10228	2	Lock Washer, 1/2"
	G10102	2	Hex Nut, 1/2"-13
17.	GA5105	2	Sprocket, 15 Tooth
18.	G10233	10	Machine Bushing
19.	GD10349	1	Bottom Shaft, 7/8" x 9 1/2" (Machines Without Point Row Clutches Only.)
20.	GA7154	3	Sprocket, 18 Tooth
21.	GA8172	2	Cylinder Lockup
22.	GD10412	2	Lockup Mount
23.	G10305	4	Carriage Bolt, 3/8"-16 x 1"
	G10229	4	Lock Washer, 3/8"
	G10101	4	Hex Nut, 3/8"-16
24.	G3310-74	2	Chain, No. 40, 74 Pitch Including Connector Link
	GR0912	-	Connector Link, No. 40
25.	GD5212	2	Coupler, 1 3/4"
26.	GD2548-81	2	Drill Shaft, 7/8" Hex, 8 Row 38"/40" And 12 Row 30"
	GD2548-99	-	Drill Shaft, 7/8" Hex, 12 Row 36"/38"
	GD2548-111	-	Drill Shaft, 7/8" Hex, 12 Row 38"/40" And 16 Row 30"
27.	GA7302	2	Spacer
28.	GA8002	2	U-Joint W/Grease Fitting, Female, 66 3/8", 8 Row 38"/40" And 12 Row 30"
	GA8045	-	U-Joint W/Grease Fitting, Female, 82 1/2", 12 Row 36"/38"/40" And 16 Row 30"
	GR1365	-	Outer Yoke
	GR1294	-	Cross And Bearing Kit
	GR1352	-	Inner Yoke
	GR1300	-	Grease Fitting
	GR1301	-	Pin
29.	GA8001	2	U-Joint W/Grease Fitting, Male, 40 13/32"
	GR1365	-	Outer Yoke
	GR1294	-	Cross And Bearing Kit
	GR1295	-	Inner Yoke
	GR1300	-	Grease Fitting
	GR1301	-	Pin
30.	GD10521	1	Angle, L.H.
	GD10520	-	Angle, R.H.
31.	GD10343	2	Mount
32.	GD5212	2	Coupler, 1 3/4", 12 Row 30" And 16 Row 30"
	GD9378	-	Coupler, 12", 8 Row 38"/40" And 12 Row 38"/40"
33.	GA5114	-	Sprocket, 30 Tooth (Machines With Point Row Clutches)
34.	GD1256	2	Spring
35.	G10464	2	Cotter Pin, 3/16" x 1"
36.	GA0378	1	Block And Hub Assembly
37.	GD1255	2	"L" Pin
38.	GA5165	1	Hub/Sprocket Assembly, 30 Tooth
39.	G10430	1	Ring
A.	GA5164	-	Ratchet Sprocket Assembly (Items 34-39)

MARKER ASSEMBLY, TWO-FOLD LOW PROFILE 8 ROW 38"/40" AND 12 ROW 30"

MKR019/MKR008/MKR28(MKR11c)

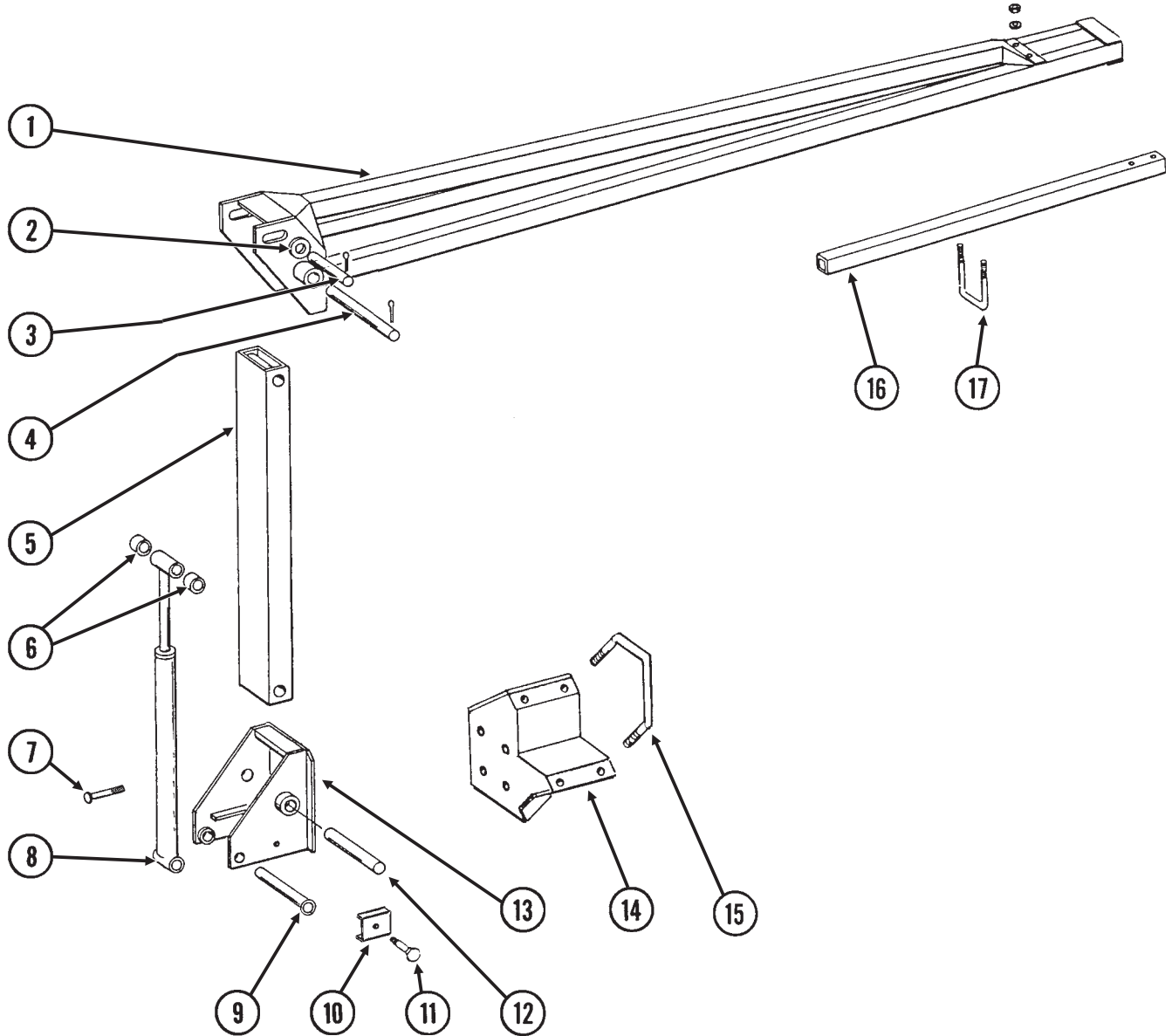

MARKER ASSEMBLY, TWO-FOLD LOW PROFILE 8 ROW 38"/40" AND 12 ROW 30"

ITEM	PART NO.	QTY.	DESCRIPTION
		(Per Assy.)	
1.	GA4353	1	Arm W/Grease Fittings, 12 Row 30"
	G10641	-	Grease Fitting, 1/8" NPT
	GA5192	-	Arm, 8 Row 38"/40"
2.	G10226	-	Washer, 1 1/4" SAE (As Required)
	G10159	-	Machine Bushing, 10 Gauge (As Required)
	G10322	-	Machine Bushing, 18 Gauge (As Required)
3.	GD2161	1	Pin, 1 1/4" x 8 1/2"
	G10460	2	Cotter Pin, 1/4" x 2"
4.	GD3214	1	Pin, 1 1/4" x 12 1/4"
	G10460	2	Cotter Pin, 1/4" x 2"
5.	GA5173	1	First Stage W/Grease Fittings
	G10641	-	Grease Fitting, 1/8" NPT
6.	GD0752-41	4	Sleeve, 1"
7.	G10008	4	Hex Head Cap Screw, 5/8"-11 x 2"
	G10205	8	Washer, 5/8" SAE
	G10230	4	Lock Washer, 5/8"
	G10104	4	Hex Nut, 5/8"-11
8.		-	See "Marker Cylinder", Page P68
9.	GA6532	1	Pin, 1 1/4" x 7 5/8"
	G10460	1	Cotter Pin, 1/4" x 2"
10.	GD5892	1	Hose Clamp, 5/8" x 1 1/2" x 1 1/2"
11.	G10133	1	Hex Head Cap Screw, 5/16"-18 x 1 1/2"
	G10232	1	Lock Washer, 5/16"
	G10106	1	Hex Nut, 5/16"-18
12.	GD0652	1	Pin, 1 1/4" x 9 1/2"
	G10460	2	Cotter Pin, 1/4" x 2"
13.	GA5130	1	Mount
14.	GA7347	1	Mount
15.	GD8175	2	U-Bolt, 7" x 7" (Diamond) x 5/8"-11
	G10205	4	Washer, 5/8" SAE
	G10230	4	Lock Washer, 5/8"
	G10104	4	Hex Nut, 5/8"-11
16.	GD0453-08	1	Extension Tube, 65", 8 Row 38"/40"
	GD0453-07	-	Extension Tube, 45", 12 Row 30"
17.	GD2721	1	U-Bolt, 2" x 2" x 1/2"-13
	G10228	2	Lock Washer, 1/2"
	G10102	2	Hex Nut, 1/2"-13

MARKER ASSEMBLY, TWO-FOLD LOW PROFILE 12 ROW 36"/38"/40" AND 16 ROW 30"

MKR019/MKR023/MKR027/MKR029(MKR12d/MKR13)

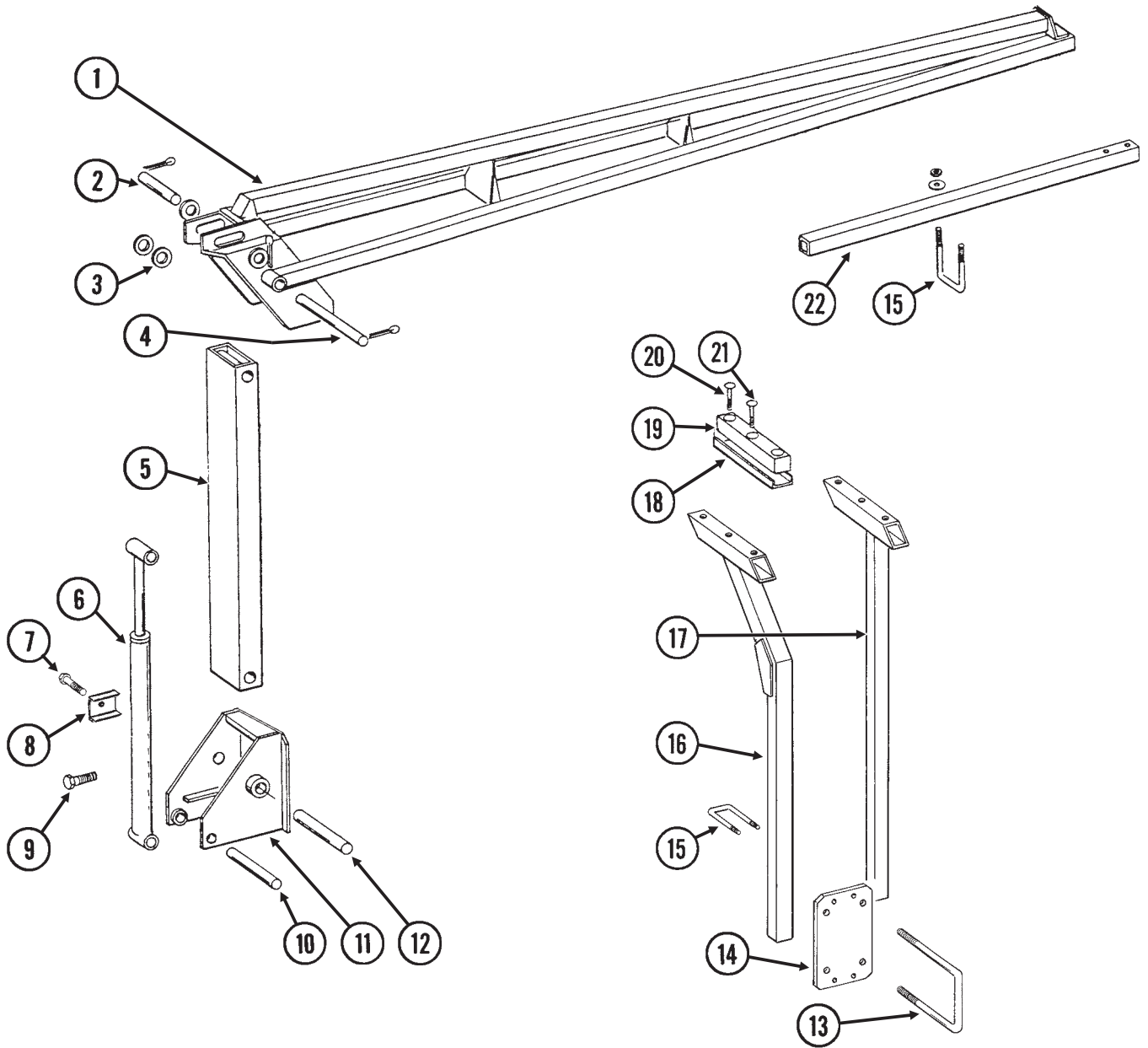

MARKER ASSEMBLY, TWO-FOLD LOW PROFILE 12 ROW 36"/38"/40" AND 16 ROW 30"

ITEM	PART NO.	QTY. (Per Assy.)	DESCRIPTION
1.	GA7116	1	Arm, 138 1/4", 12 Row 36"/38"/40"
	GA7118	-	Arm, 172 1/4", 16 Row 30"
2.	GD1701	1	Pin, 1 1/4" x 6 1/2"
	G10460	2	Cotter Pin, 1/4" x 2"
3.	G10226	-	Washer, 1 1/4" SAE (As Required)
	G10159	-	Machine Bushing, 10 Gauge (As Required)
	G10322	-	Machine Bushing, 18 Gauge (As Required)
4.	GD0737	1	Pin, 1 1/4" x 13 1/4"
	G10460	2	Cotter Pin, 1/4" x 2"
5.	GA0151	1	First Stage W/Grease Fittings
	G10641	-	Grease Fitting, 1/8" NPT
6.		-	See "Marker Cylinder", Page P68
7.	G10133	1	Hex Head Cap Screw, 5/16"-18 x 1 1/2"
	G10232	1	Lock Washer, 5/16"
	G10106	1	Hex Nut, 5/16"-18
8.	GD5875	1	Hose Clamp, 9/16" x 2 1/2" x 2"
9.	G10008	4	Hex Head Cap Screw, 5/8"-11 x 2"
	G10230	4	Lock Washer, 5/8"
	G10104	4	Hex Nut, 5/8"-11
10.	GD0652	1	Pin, 1 1/4" x 9 1/2"
	G10460	2	Cotter Pin, 1/4" x 2"
11.	GA7415	1	Mount
12.	GD7209	1	Pin, 1 1/4" x 11 1/2"
	G10049	1	Hex Head Cap Screw, 3/8"-16 x 2 1/2"
	G10108	1	Lock Nut, 3/8"-16
13.	GD1114	2	U-Bolt, 7" x 7" x 5/8"-11
	G10230	4	Lock Washer, 5/8"
	G10104	4	Hex Nut, 5/8"-11
14.	GD10577	1	Bar, 7" x 11 1/2"
15.	GD2721	3	U-Bolt, 2" x 2" x 1/2"-13
	G10228	6	Lock Washer, 1/2"
	G10102	6	Hex Nut, 1/2"-13
16.	GA7354	-	Stand, R.H.
17.	GA7353	1	Stand, L.H.
18.	GD6772	1	Retainer
19.	GD4512	1	Rubber Stop
20.	G10039	2	Hex Head Cap Screw, 1/2"-13 x 1 3/4"
	G10206	2	Washer, 1/2" SAE
	G10228	2	Lock Washer, 1/2"
	G10102	2	Hex Nut, 1/2"-13
21.	G10033	1	Hex Head Cap Screw, 1/2"-13 x 3 1/2"
	G10206	1	Washer, 1/2" SAE
	G10228	1	Lock Washer, 1/2"
	G10102	1	Hex Nut, 1/2"-13
22.	GD0453-09	1	Extension Tube, 75", 12 Row 38"/40"
	GD0453-10	-	Extension Tube, 73", 12 Row 36"/38"
	GD0453-03	-	Extension Tube, 50", 16 Row 30"

MARKER SPINDLE/HUB/BLADE

MKR020(MKR4)

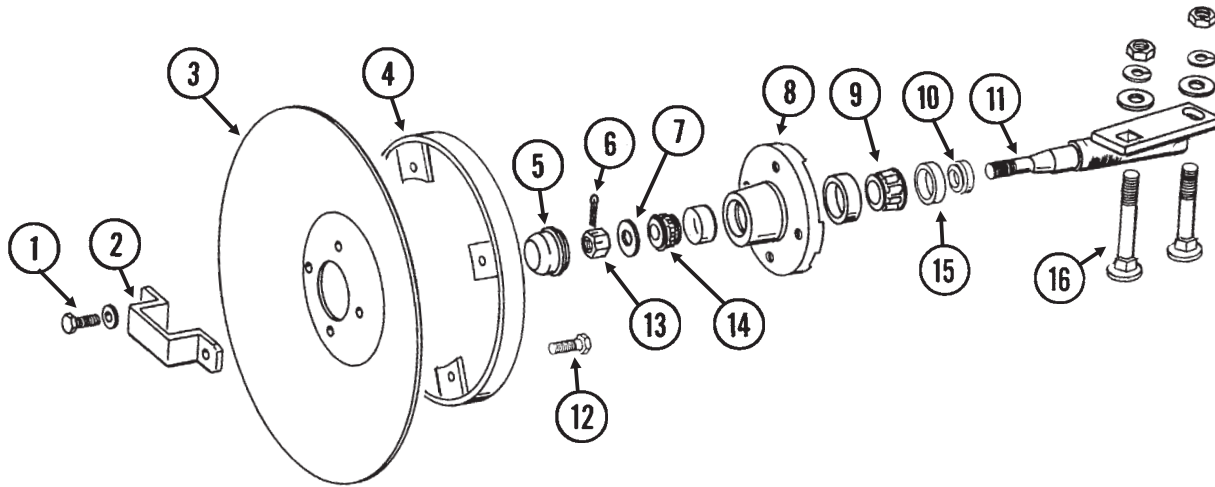

ITEM	PART NO.	QTY. (Per Assy.)	DESCRIPTION
1.	G10722	4	Hex Head Cap Screw, 1/2"-20 x 1"
	G10228	4	Lock Washer, 1/2"
2.	GD2597	1	Retainer
3.	GD0746	1	Solid Blade, 16" (Shown)
	GD10283	-	Notched Blade, 16" (Optional)
4.	GA5853	1	Depth Band
5.	GD0840	1	Cap
6.	G10544	1	Cotter Pin, 5/32" x 1"
7.	G10724	1	Washer, 5/8"
8.	GA0167	1	Hub With Cups
	GR0151	-	Outer Cup
	GR0150	-	Inner Cup
9.	GA0245	1	Inner Bearing
10.	GA0899	1	Rubber Seal
11.	GA1677	1	Spindle, L.H. (Shown)
	GA1676	-	Spindle, R.H.
12.	G10019	4	Hex Head Cap Screw, 5/16"-18 x 1"
	G10109	4	Lock Nut, 5/16"-18
13.	G10725	1	Hex Slotted Nut, 5/8"-18
14.	GA0257	1	Outer Bearing
15.	GA0243	1	Grease Seal
16.	G10844	2	Carriage Bolt, 1/2"-13 x 3 1/2"
	G10168	2	Machine Bushing, 1/2", 7 Gauge
	G10228	2	Lock Washer, 1/2"
	G10102	2	Hex Nut, 1/2"-13
A.	GA1679	-	Hub And Spindle Assembly, L.H. (Items 1, 2, 5-11 And 13-15)
	GA1678	-	Hub And Spindle Assembly, R.H. (Items 1, 2, 5-11 And 13-15)

FOLD HYDRAULIC SYSTEM

A7386(HYD1/HYD2/HYD16)

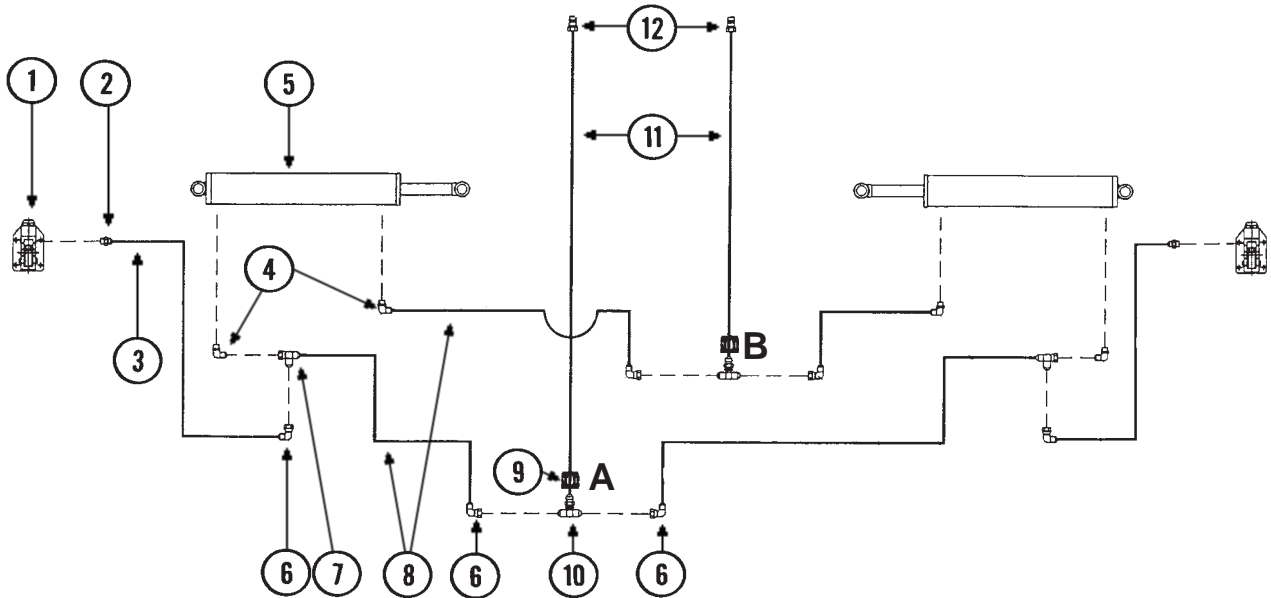
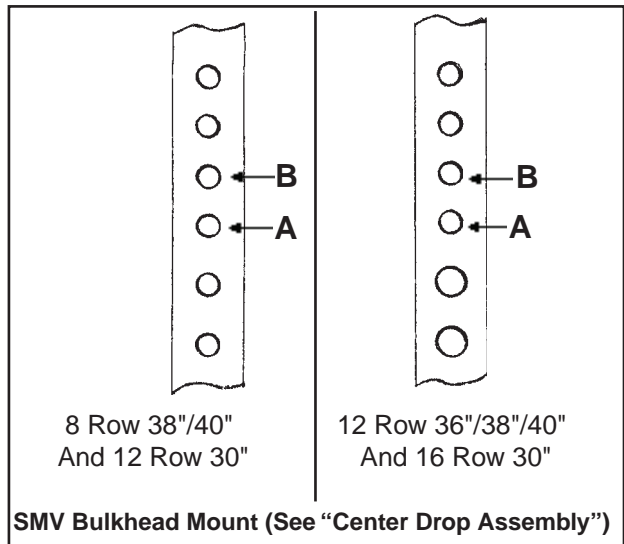

ITEM	PART NO.	QTY.	DESCRIPTION
1.		-	See "Wing Assembly" (Hydraulic Latch), Pages P28 And P29 Item 9
2.	G6400-06-04	2	Connector, 1/16"-18 JIC To 7/16"-20 O-Ring
3.	*A1188	2	Hose Assembly, 1/4" x 66", 8 Row 38"/40" And 12 Row 30"
	*A1102	-	Hose Assembly, 1/4" x 95", 12 Row 36"/38"/40" And 16 Row 30"
4.	G6801-06-08	2-4	Elbow, 1/16"-18 Male JIC To 3/4"-16 O-Ring
	G6400-06-08	2	Adapter, 1/16"-18 Male JIC To 3/4"-16 O-Ring
5.		-	See "Wing Fold Cylinder", Page P67
6.	G6500-06	6	Swivel Elbow, 1/16"-18 Male JIC To Female
7.	G6602-06	2	Swivel Tee, 1/16"-18 JIC
8.	*A1113	4	Hose Assembly, 1/4" x 80"
9.	G306-06	2	Lock Nut, 1/16"-18
10.	G2703-06	2	Bulkhead Tee, 1/16"-18 JIC
11.	*A1198	2	Hose Assembly, 1/4" x 60"
12.	GD4086	2	ISO Coupler

* Hydraulic hose is not stocked by KINZE® Repair Parts, but can be made available on a special order basis. Call for quote.

MARKER HYDRAULIC SYSTEM

(HYD2-17)

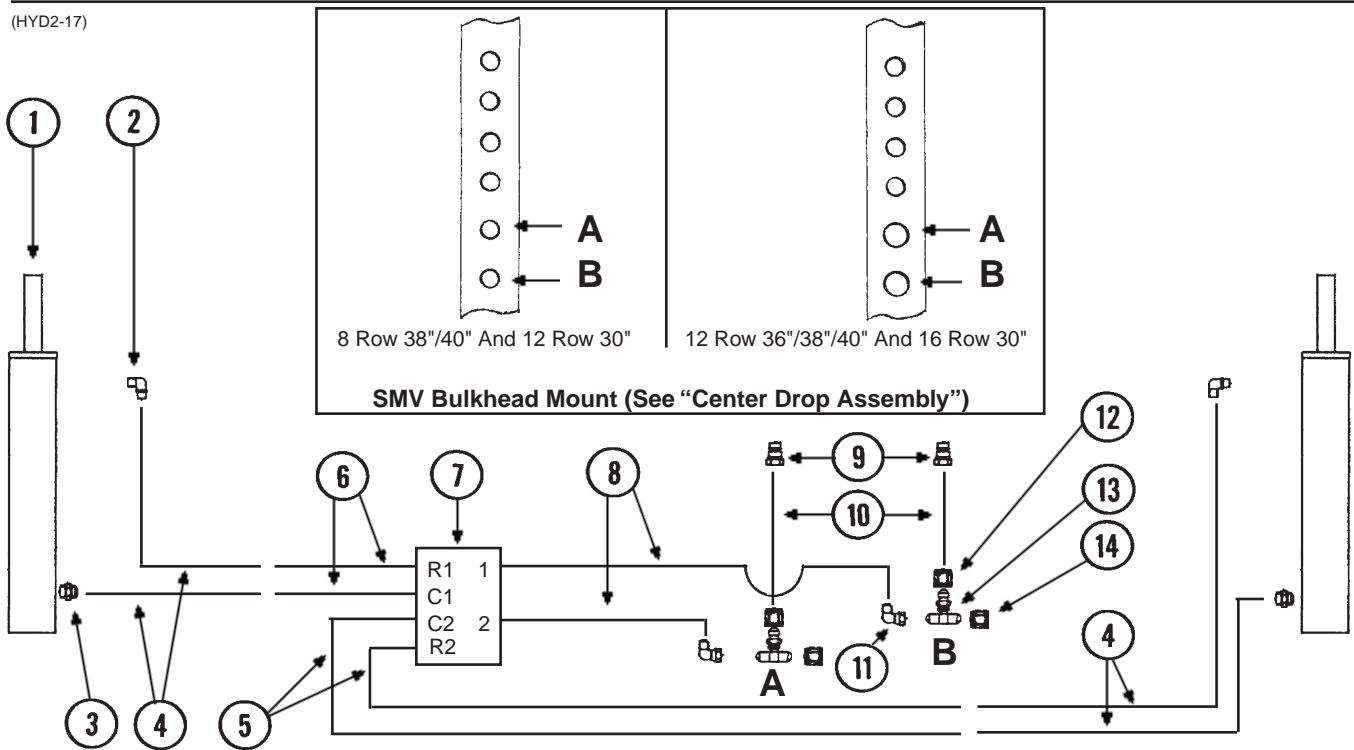

ITEM	PART NO.	QTY.	DESCRIPTION
1.		-	See "Marker Cylinder", Page P68
2.	G6801-06-08	2	Elbow, 1/16"-18 Male JIC To 3/4"-16 O-Ring, 8 Row 38"/40" And 12 Row 30"
	G6801-08	-	Elbow, 3/4"-16 Male JIC To 3/4"-16 O-Ring, 12 Row 36"/38"/40" And 16 Row 30"
3.	G6400-06-08	2	Connector, 1/16"-18 Male JIC To 3/4"-16 O-Ring, 8 Row 38"/40" And 12 Row 30"
	G6400-06-04	-	Connector, 1/16" Male JIC To 7/16" O-Ring, 8 Row 38"/40" And 12 Row 30"
	G6400-08	-	Connector, 3/4"-16 Male JIC To 3/4"-16 O-Ring, 12 Row 36"/38"/40" And 16 Row 30"
	G6400-08-04	-	Connector, 3/4" Male JIC To 7/16" O-Ring, 12 Row 36"/38"/40" And 16 Row 30"
4.	*A1176	4	Hose Assembly, 1/4" x 48", 8 Row 38"/40" And 12 Row 30"
	*A1072	-	Hose Assembly, 3/8" x 48", 12 Row 36"/38"/40" And 16 Row 30"
5.	*A1118	2	Hose Assembly, 1/4" x 295", 8 Row 38"/40" And 12 Row 30"
	*A3200	-	Hose Assembly, 3/8" x 354", 12 Row 36"/38"
	*A3192	-	Hose Assembly, 3/8" x 334", 12 Row 38"/40" And 16 Row 30"
6.	*A1109	2	Hose Assembly, 1/4" x 145", 8 Row 38"/40" And 12 Row 30"
	*A3201	-	Hose Assembly, 3/8" x 176", 12 Row 36"/38"
	*A3191	-	Hose Assembly, 3/8" x 185", 12 Row 38"/40" And 16 Row 30"
7.		-	See "Marker Sequencing/Flow Control Valve And Mount", Page P65
8.	*A1114	2	Hose Assembly, 1/4" x 85", 8 Row 38"/40" And 12 Row 30"
	*A3193	-	Hose Assembly, 3/8" x 100", 12 Row 36"/38"/40" And 16 Row 30"
9.	GD4086	2	ISO Coupler
10.	*A1198	2	Hose Assembly, 1/4" x 60", 8 Row 38"/40" And 12 Row 30"
	*A1047	-	Hose Assembly, 3/8" x 60", 12 Row 36"/38"/40" And 16 Row 30"
11.	G6500-06	2	Swivel Elbow, 1/16"-18, 8 Row 38"/40" And 12 Row 30"
	G6500-08	-	Swivel Elbow, 3/4"-16, 12 Row 36"/38"/40" And 16 Row 30"
12.	G306-06	2	Lock Nut, 1/16"-18, 8 Row 38"/40" And 12 Row 30"
	G306-08	-	Lock Nut, 3/4"-16, 12 Row 36"/38"/40" And 16 Row 30"
13.	G2703-06	2	Bulkhead Tee, 1/16"-18 JIC, 8 Row 38"/40" And 12 Row 30"
	G2703-08	-	Bulkhead Tee, 3/4"-16 JIC, 12 Row 36"/38"/40" And 16 Row 30"
14.	G304-C-06	2	Cap Nut, 1/16"-18, 8 Row 38"/40" And 12 Row 30"
	G304-C-08	-	Cap Nut, 3/4"-16, 12 Row 36"/38"/40" And 16 Row 30"

* Hydraulic hose is not stocked by KINZE® Repair Parts, but can be made available on a special order basis. Call for quote.

DUAL LIFT ASSIST WHEEL PACKAGE HYDRAULIC SYSTEM

(HYD2-17)

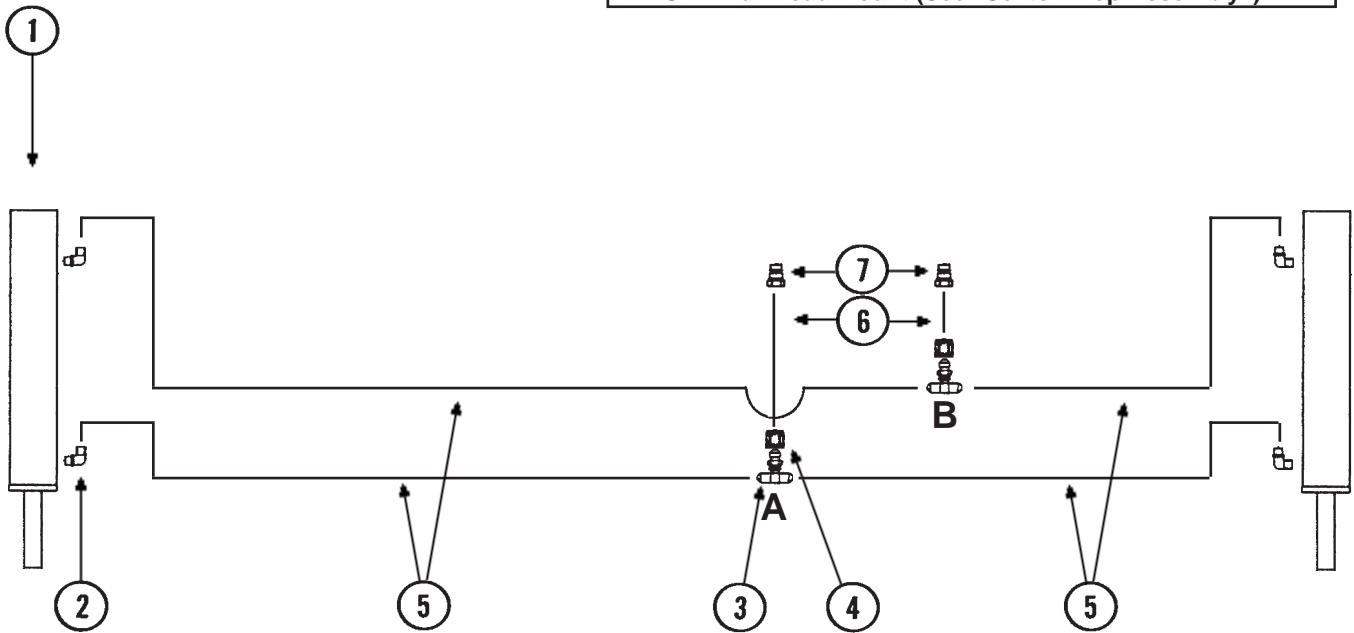
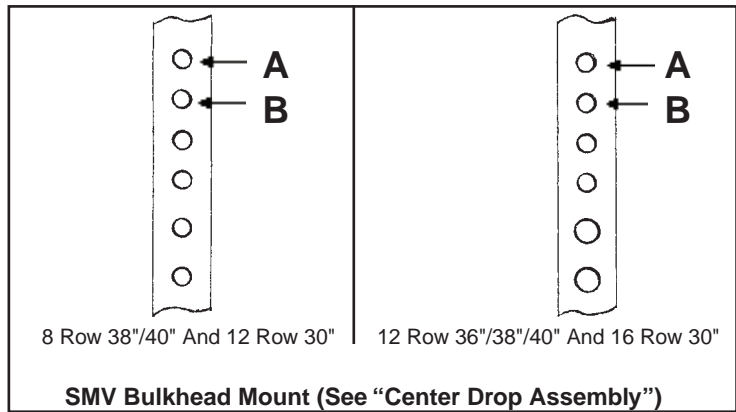

ITEM	PART NO.	QTY.	DESCRIPTION
1.		-	See "Dual Lift Assist Cylinder", Page P70
2.	G2501-06-08	4	Elbow, 1/16"-18 JIC To 1/2" NPT
3.	G2703-06	2	Bulkhead Tee, 1/16"-18 JIC
4.	G306-06	2	Lock Nut, 1/16"-18
5.	*A1116	4	Hose Assembly, 1/4" x 136"
6.	*A1198	2	Hose Assembly, 1/4" x 60"
7.	GD4086	2	ISO Coupler

* Hydraulic hose is not stocked by KINZE® Repair Parts, but can be made available on a special order basis. Call for quote.

DUAL LIFT ASSIST WHEEL PACKAGE HYDRAULIC SYSTEM (Plumbed Into 3 Point Lift Circuit)

(HYD2-17)

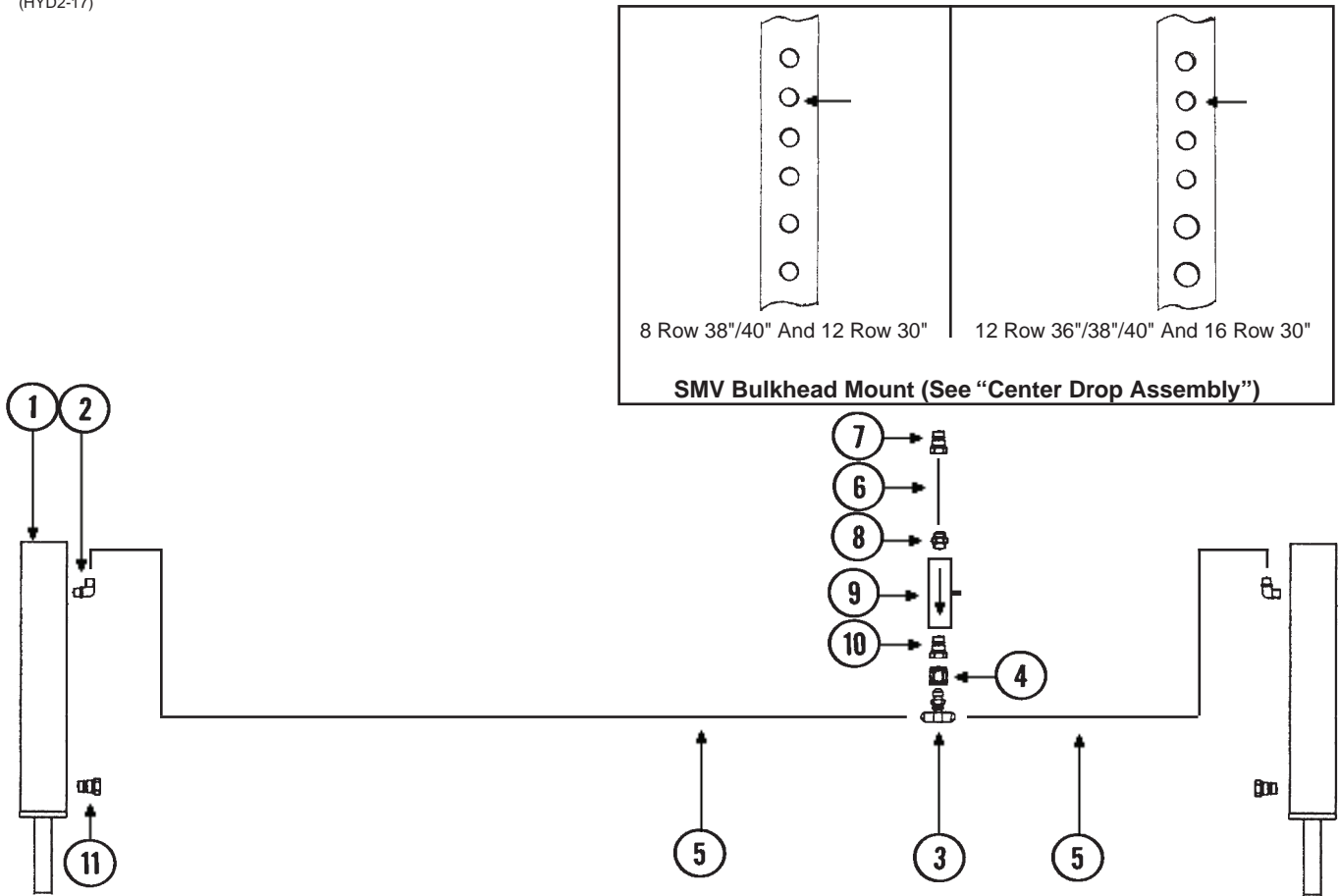

ITEM	PART NO.	QTY.	DESCRIPTION
1.		-	See "Dual Lift Assist Cylinder", Page P70
2.	G2501-06-08	2	Elbow, 1/16"-18 JIC To 1/2" NPT
3.	G2703-06	1	Bulkhead Tee, 1/16"-18 JIC
4.	G306-06	1	Lock Nut, 1/16"-18
5.	*A1116	2	Hose Assembly, 1/4" x 136"
6.	*A1198	1	Hose Assembly, 1/4" x 60"
7.	GD4086	1	ISO Coupler
8.	G2404-06-06	1	Adapter, 1/16"-18 JIC To 3/8" NPT Male
9.		-	See "Flow Control Valve", Page P66
10.	G6505-06-06	1	Adapter, 1/16"-18 JIC Female To 3/8" NPT Male
11.	GA7861	2	Breather Plug, 1/2" NPT

* Hydraulic hose is not stocked by KINZE® Repair Parts, but can be made available on a special order basis. Call for quote.

WING DOWN FLEX CYLINDER PACKAGE HYDRAULIC SYSTEM

(HYD2-17)

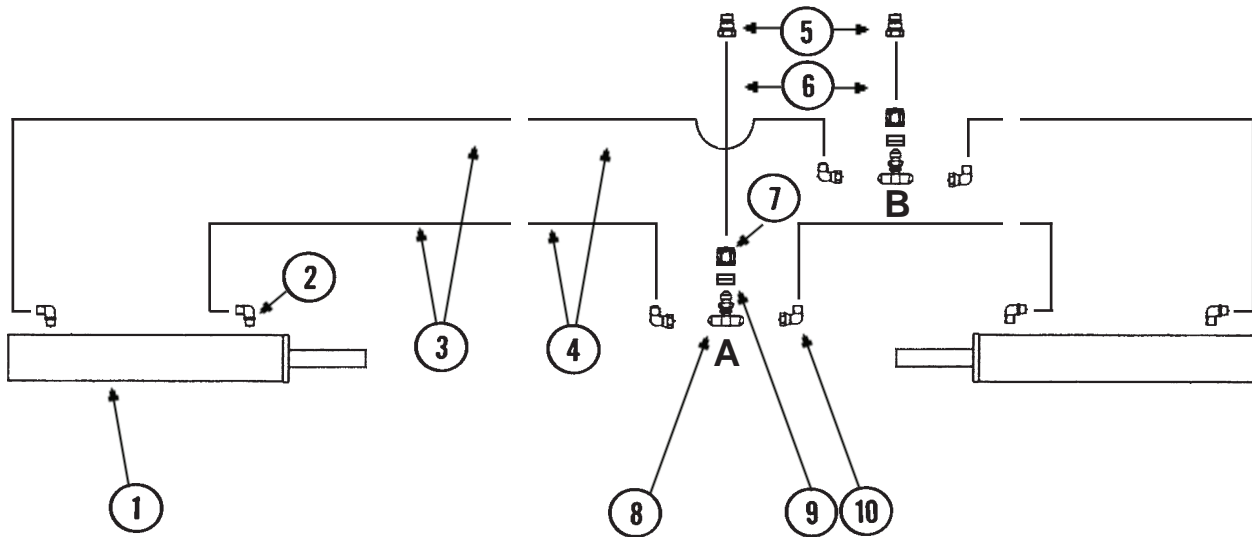
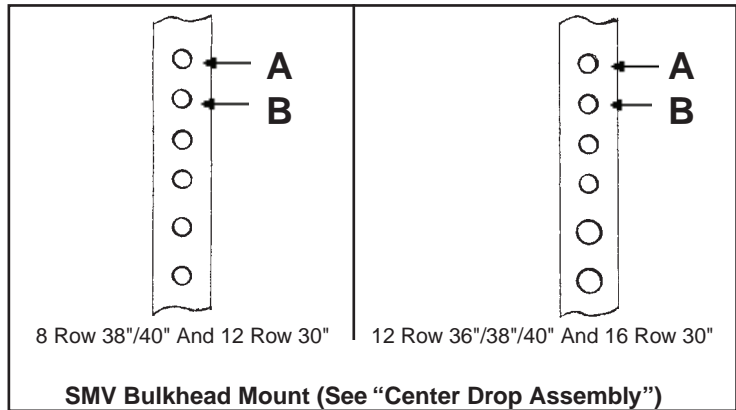

ITEM	PART NO.	QTY.	DESCRIPTION
1.		-	See "Wing Down Flex Cylinder", Page P69
2.	G6801-06-08	4	Elbow, 1/16"-18 JIC To 3/4"-16 O-Ring
3.	*A7600	4	Hose Assembly, 1/4" x 260"
4.	*A7601	4	Hose Assembly, 1/4" x 80", 12 Row 36"/38"/40" And 16 Row 30" Only
5.	GD4086	2	ISO Coupler
6.	*A1198	2	Hose Assembly, 1/4" x 60"
7.	G306-06	2	Lock Nut, 1/16"-18
8.	G2703-06	2	Bulkhead Tee, 1/16"-18 JIC
9.	G10159	4	Bushing, 1 7/8" O.D. x 1 3/32" I.D. x 10 Gauge
10.	G6500-06	4	Swivel Elbow, 1/16"-18

* Hydraulic hose is not stocked by KINZE® Repair Parts, but can be made available on a special order basis. Call for quote.

DUAL LIFT ASSIST WHEEL PACKAGE AND WING DOWN FLEX CYLINDER PACKAGE HYDRAULIC SYSTEM

(HYD2-17)

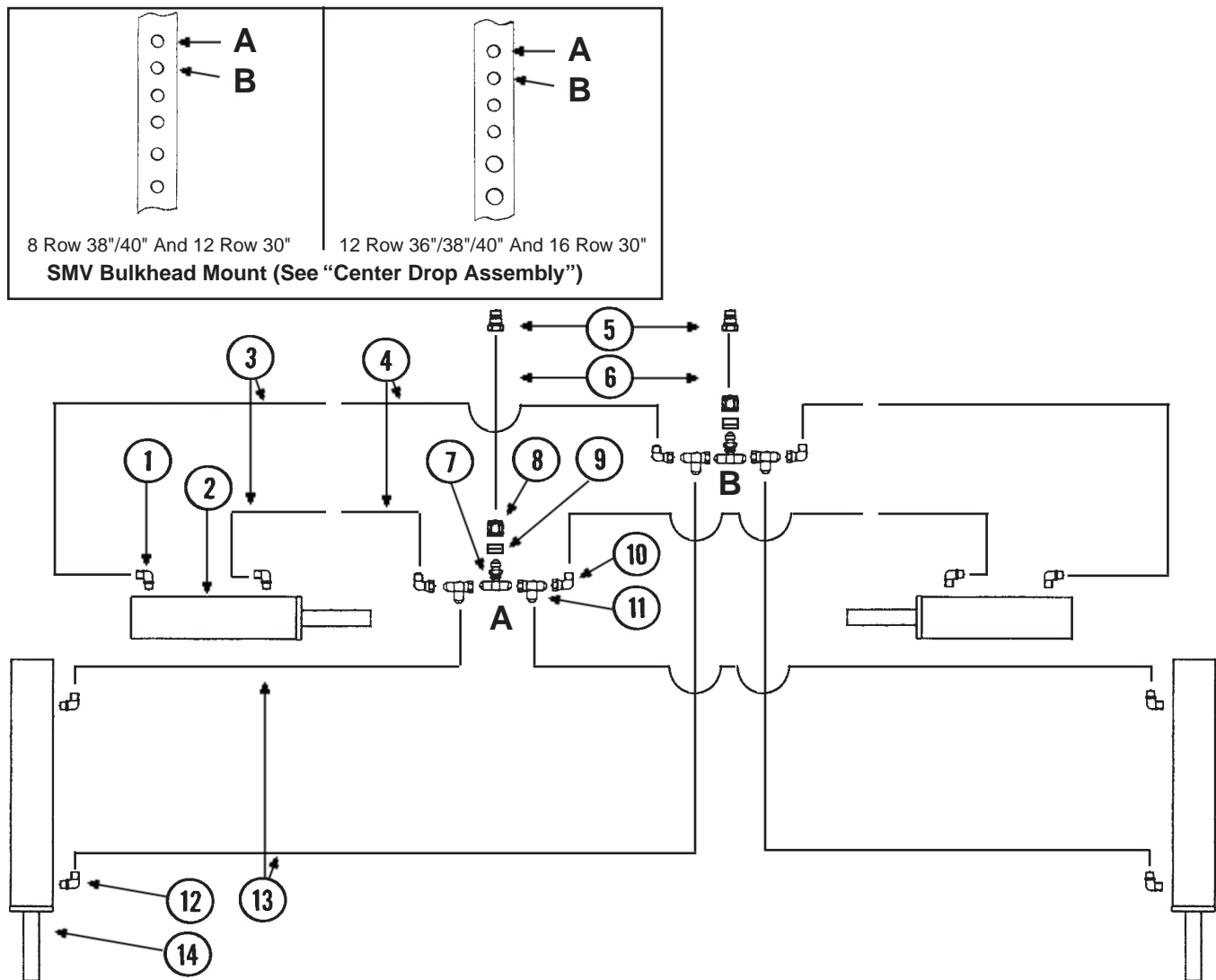

ITEM	PART NO.	QTY.	DESCRIPTION
1.	G6801-06-08	4	Elbow, 1/16"-18 JIC To 3/4"-16 O-Ring
2.		-	See "Wing Down Flex Cylinder", Page P69
3.	*A7600	4	Hose Assembly, 1/4" x 260"
4.	*A7601	4	Hose Assembly, 1/4" x 80", 12 Row 36"/38"/40" And 16 Row 30" Only
5.	GD4086	2	ISO Coupler
6.	*A1198	2	Hose Assembly, 1/4" x 60"
7.	G2703-06	2	Bulkhead Tee, 1/16"-18 JIC
8.	G306-06	2	Lock Nut, 1/16"-18
9.	G10159	4	Bushing, 1 7/8" O.D. x 1 1/2" I.D. x 10 Gauge
10.	G6500-06	4	Swivel Elbow, 1/16"-18
11.	G6602-06	4	Swivel Tee, 1/16"-18 JIC
12.	G2501-06-08	4	Elbow, 1/16"-18 JIC To 1/2" NPT
13.	*A1116	4	Hose Assembly, 1/4" x 136"
14.		-	See "Dual Lift Assist Cylinder", Page P70

* Hydraulic hose is not stocked by KINZE® Repair Parts, but can be made available on a special order basis. Call for quote.

MARKER SEQUENCING/FLOW CONTROL VALVE AND MOUNT

VVB025 VVB037(PT9a/SFP7)

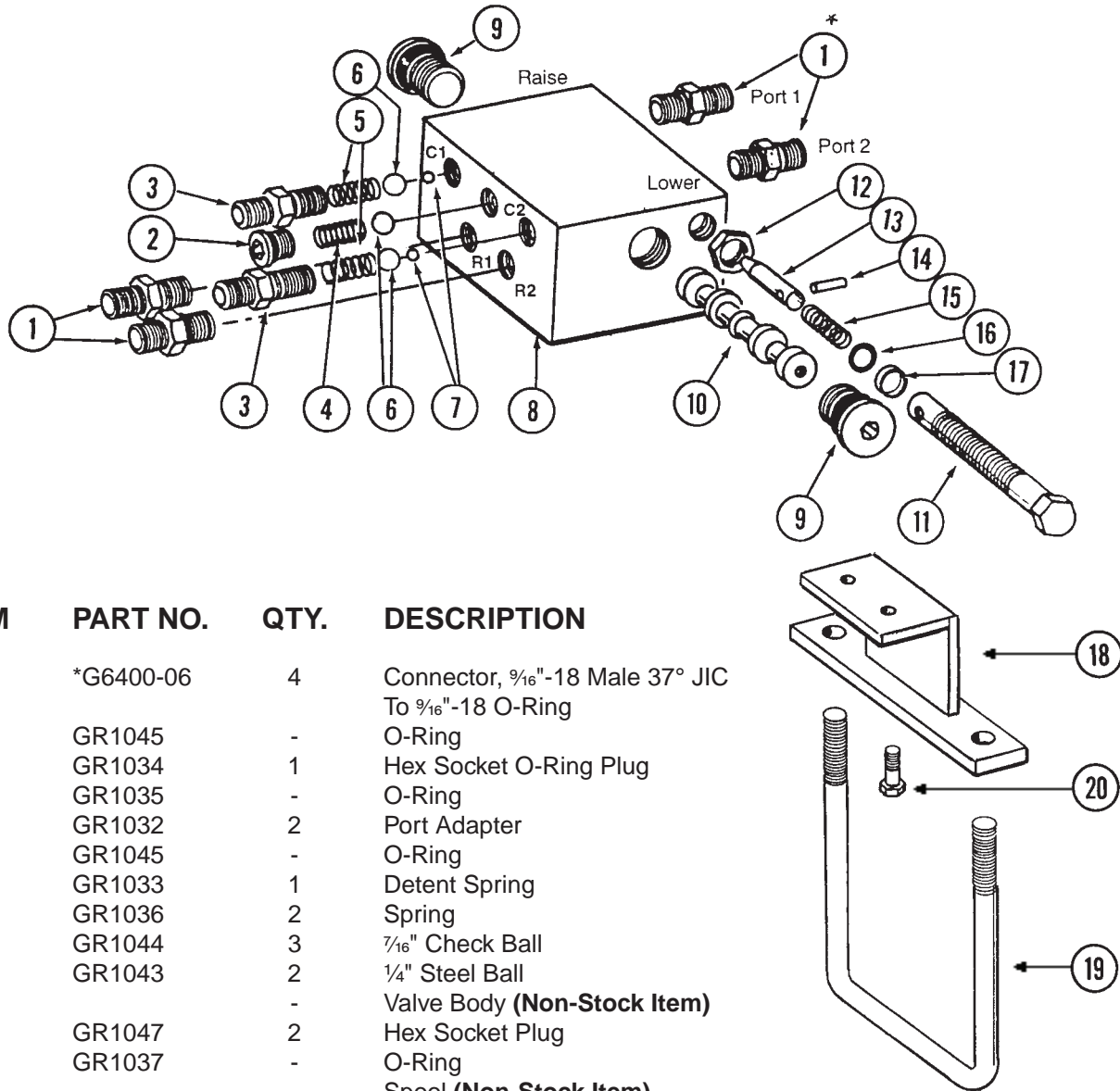

ITEM	PART NO.	QTY.	DESCRIPTION
1.	*G6400-06	4	Connector, 1/16"-18 Male 37° JIC To 1/16"-18 O-Ring
	GR1045	-	O-Ring
2.	GR1034	1	Hex Socket O-Ring Plug
	GR1035	-	O-Ring
3.	GR1032	2	Port Adapter
	GR1045	-	O-Ring
4.	GR1033	1	Detent Spring
5.	GR1036	2	Spring
6.	GR1044	3	7/16" Check Ball
7.	GR1043	2	1/4" Steel Ball
8.		-	Valve Body (Non-Stock Item)
9.	GR1047	2	Hex Socket Plug
	GR1037	-	O-Ring
10.		-	Spool (Non-Stock Item)
11.	GR1042	2	Adjustment Screw
12.	GR1048	2	Hex Jam Nut, 1/2"-20
13.	GR1038	2	Needle
14.	GR1039	2	Spring Pin
15.	GR1046	2	Compression Spring
16.	GR1040	2	O-Ring
17.	GR1041	2	Teflon BU Ring
18.	GA7341	1	Mount
19.	GD7145	1	U-Bolt, 7" x 7" x 1/2"-13
	G10228	2	Lock Washer, 1/2"
	G10102	2	Hex Nut, 1/2"-13
20.	G10001	2	Hex Head Cap Screw, 3/8"-16 x 1"
	G10229	2	Lock Washer, 3/8"
A.	GA5552	-	Valve Assembly Complete (Items 1-17)
B.	GA5572	-	Flow Control Portion Only (Items 11-17)

*Not used on sizes with 3/8" hoses.

FLOW CONTROL VALVE

WB001(MT2)

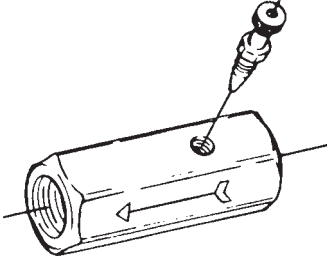

ITEM	PART NO.	QTY.	DESCRIPTION
A.	GA0270	-	Flow Control Valve ("Parker" Stamped On Valve Body)
	GR0767	-	Needle Valve Only

WING FOLD CYLINDER, 8 ROW 38"/40" AND 12 ROW 30"

CYL29(CYL16a)

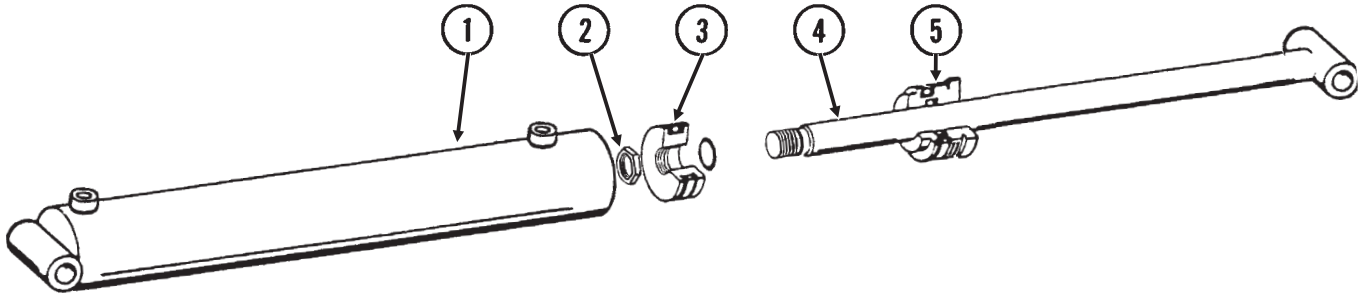

ITEM	PART NO.	QTY.	DESCRIPTION
------	----------	------	-------------

1.	GA7501	1	Barrel
2.	GR0987	1	Lock Nut, 1 1/4"-12
3.	GD6568	1	Piston
4.	GA4312	1	Rod Assembly
5.	GD6569	1	Gland
A.	GA7338	-	Cylinder Complete, 3 1/2" x 20"
B.	GR0988	-	Seal Kit, Includes: (2)O-Ring, (1)BU Ring, (1)U-Cup, (1)Wiper, (1)Uni-Ring

WING FOLD CYLINDER, 12 ROW 36"/38"/40" AND 16 ROW 30"

CYL29(CYL16a)

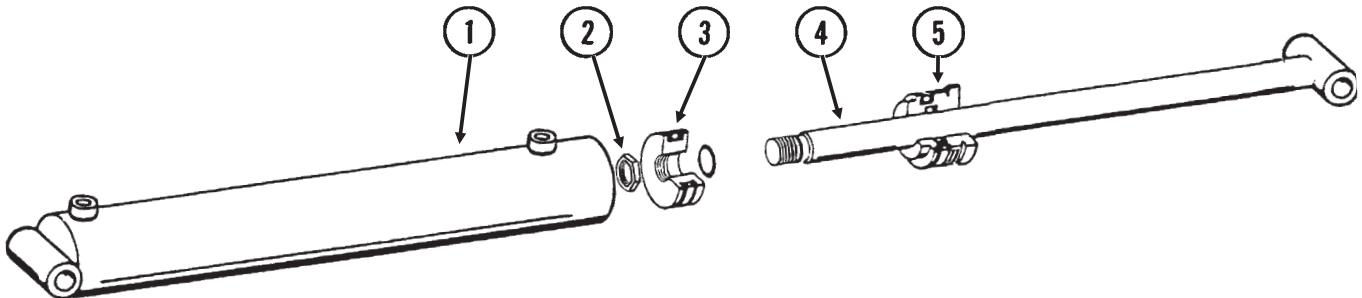

ITEM	PART NO.	QTY.	DESCRIPTION
------	----------	------	-------------

1.	GA7525	1	Barrel
2.	GR0987	1	Lock Nut, 1 1/4"-12
3.	GD10639	1	Piston
4.	GA7526	1	Rod Assembly
5.	GD7164	1	Gland
A.	GA7521	-	Cylinder Complete, 4" x 20"
B.	GR1357	-	Seal Kit, Includes: (2)O-Ring, (1)BU Ring, (1)U-Cup, (1)Wiper, (1)Uni-Ring

MARKER CYLINDER

CYL032(CYL32b)

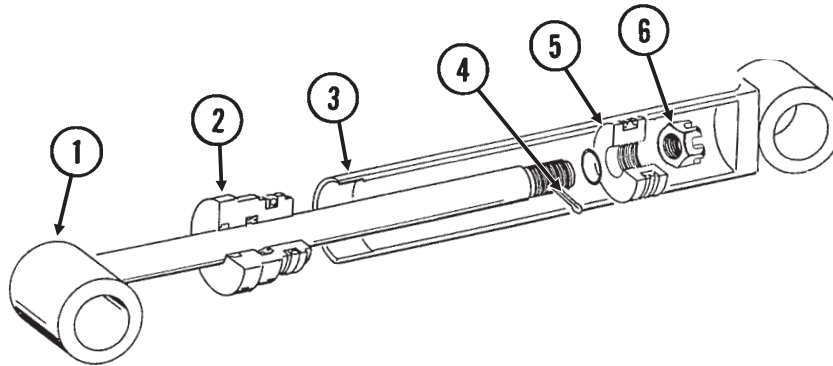

ITEM	PART NO.	QTY.	DESCRIPTION
1.	GA7219	1	Rod Assembly
2.	GD10207	1	Gland
3.	GA7524	1	Barrel
4.	G10827	1	Cotter Pin, 1/8" x 1 3/4"
5.	GD10206	1	Piston
6.	GR1308	1	Slotted Hex Nut, 7/8"-14
A.	GA7523	-	Cylinder Complete, 2 1/2" x 20 1/16"
B.	GR1309	-	Seal Kit, Includes: (1)Crown Seal, (2)O-Rings, (1)BU Ring, (1)U-Cup, (1)Wiper, (1)Cast Iron Ring

WING DOWN FLEX CYLINDER

CYL060(CYL31a)

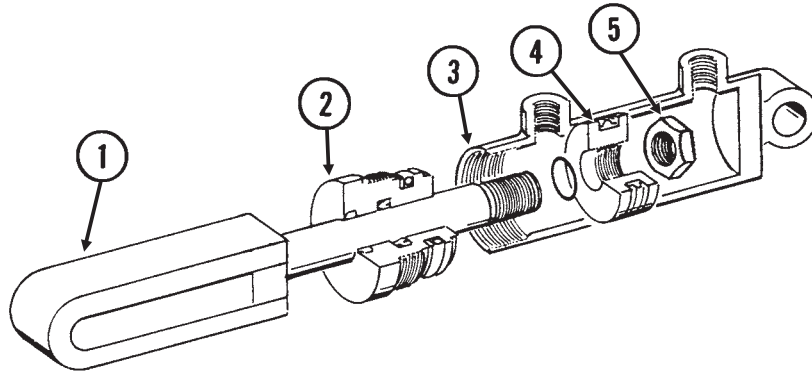

ITEM	PART NO.	QTY.	DESCRIPTION
1.	GA7503	1	Rod Assembly
2.	GD7164	1	Gland
3.	GA7502	1	Barrel
4.	GD10639	1	Piston
5.	GR0987	1	Lock Nut, 1 1/4"-12
A.	GA7348	-	Cylinder Complete, 4" x 3 1/2"
B.	GR1357	-	Seal Kit, Includes: (1) Seal, (2) O-Ring, (1) BU Wiper, (1) U-Cup, (1) Rod Wiper

DUAL LIFT ASSIST CYLINDER

CYL048(CYL22a)

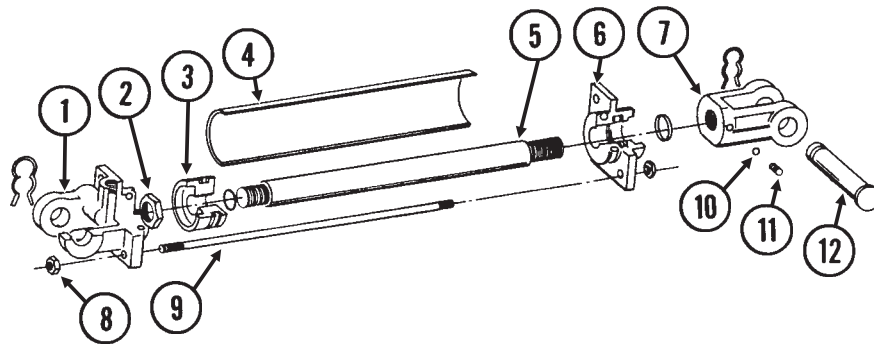

ITEM	PART NO.	QTY.	DESCRIPTION
1.	GR1027	1	Clevis
2.	GR0663	1	Lock Nut, 1"-14 UNS
3.	GR1026	1	Piston
4.		-	Barrel (Non-Stock Item)
5.	GR0709	1	Shaft
6.	GR1025	1	Gland
7.	GR0714	1	Clevis
8.	GR0181	8	Hex Nut, 1/2"-13
9.	GR1024	4	Tie Rod
10.	GR0716	1	Nylon Ball
11.	G10210	1	Set Screw, 3/8"-16 x 3/8"
12.	GR0717	2	Pin W/Clip
	GR0193	-	Clip
A.	GA5482A	-	Cylinder Complete W/Pins And Clips, 3 1/2" x 8" ("Energy" Cast In Base End Clevis.)
B.	GR1028	-	Seal Kit, Includes: (1) Wiper, (4) BU Rings, (5) O-Rings, (1) U-Cup

DUAL LIFT ASSIST CYLINDER

CYL009/CYL048(CYL23a)

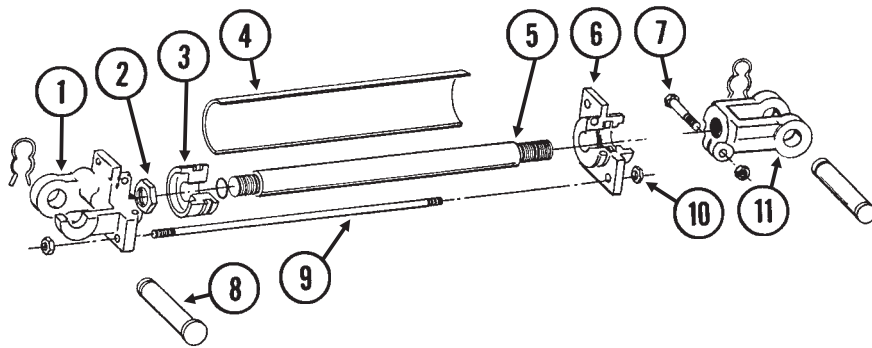

ITEM	PART NO.	QTY.	DESCRIPTION
1.	GR1270	1	Clevis
2.	GR1278	1	Special Nut, 1"-14 UNS
3.	GR1272	1	Piston
4.	GR1274	1	Barrel
5.	GR1273	1	Shaft
6.	GR1271	1	Gland
7.	G10047	1	Hex Head Cap Screw, 3/8"-16 x 1 3/4"
	G10101	1	Hex Nut, 3/8"-16
8.	GR0717	2	Pin W/Clip
	GR0193	-	Clip
9.	GR1024	4	Tie Rod
10.	GR0181	8	Hex Nut, 1/2"-13
11.	GR1276	1	Clevis
A.	GA5482B	-	Cylinder Complete W/Pins And Clips, 3 1/2" x 8" ("Lion Hydraulics" Decal On Barrel)
B.	GR1279	-	Seal Kit, Includes: (3) BU Seals, (5) O-Rings, (1) C/R Seal

ELECTRONIC SEED MONITOR

ECP017/D-0640-0001/D-0640-0003/D-0640-0004/D-1172-0001/D-1172-0002/ECP019/ECP020/ECP021/ECP022(MTR8a)

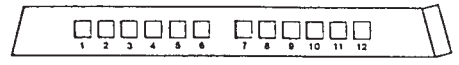
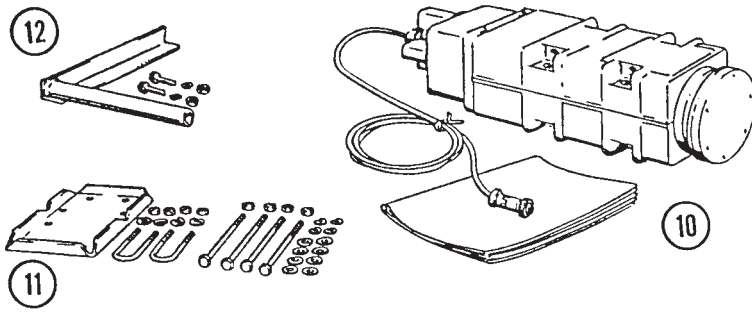

13



14

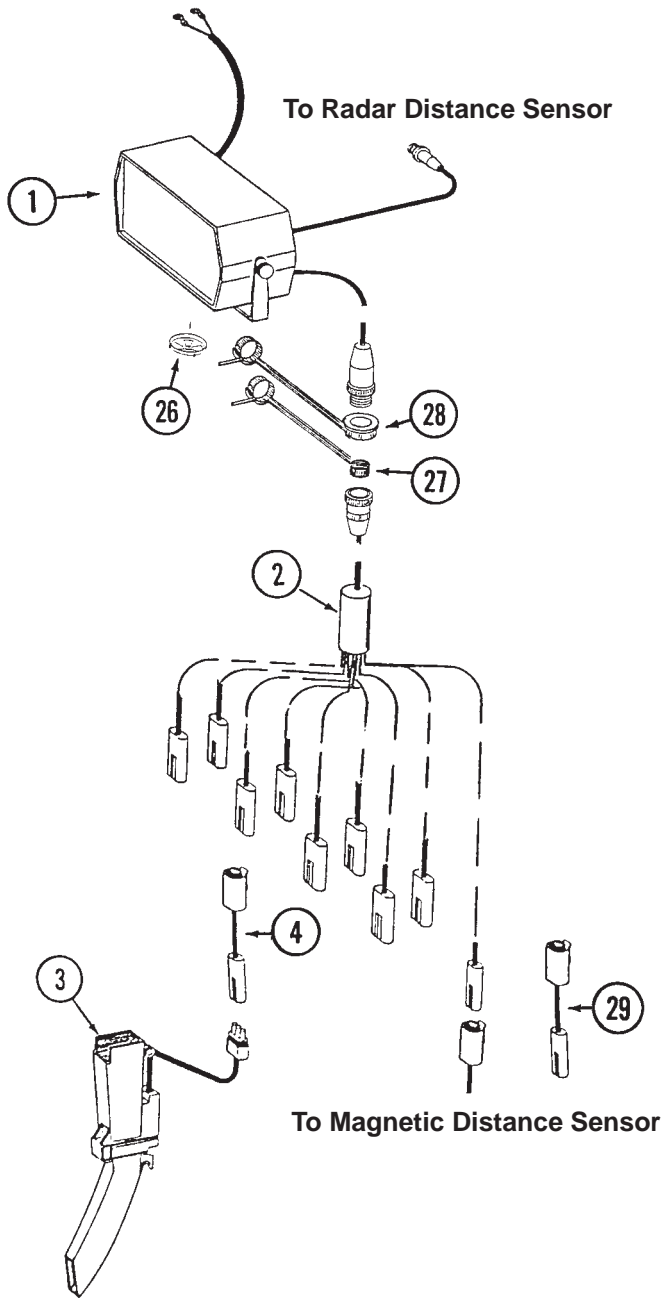

To Radar Distance Sensor

To Magnetic Distance Sensor

ELECTRONIC SEED MONITOR

ITEM	PART NO.	QTY.	DESCRIPTION
1.	GA5873	1	Console W/Mounting Bracket, KM1000
	GA5874	-	Console W/Mounting Bracket, KM3000
	GR1077	-	Mounting Bracket, KM1000
	GR1078	-	Mounting Bracket, KM3000
	GR1079	-	Console Mounting Bracket Hardware Package (Includes 2 Wellnuts, 2 Knobs And ¼" Hardware)
2.	GA5877	1	Planter Harness, 8 Row
	GA5878	-	Planter Harness, 12 Row
	GA5879	-	Planter Harness, 16 Row
3.	GA5880	-	Seed Tube W/High Rate Sensor
	GR1062	-	Seed Tube (With Holes For High Rate Sensor Installation)
	GR1087	-	Sensor Only (For GA5880)
	GR0676	-	Sunshade
	GD2117	-	Tie Strap, 14 ½"
4.	GA7439	-	Extension, 4', Between Planter Harness And Seed Tube (8 Row Uses 8, 12 Row Uses 10, 16 Row Uses 12)
5.	GA5600	1	Magnetic Distance Sensor (Use W/KM3000 Console Only)
6.	GD8770	1	Bracket
7.	G10004	2	Hex Head Cap Screw, ⅜"-16 x 1 ¼"
	G10229	2	Lock Washer, ⅜"
	G10101	2	Hex Nut, ⅜"-16
8.	GD8771	1	Spring Wave Washer
9.	GD8751	-	Magnetic Distance Sensor Pulse Wheel (Use W/KM3000 Console Only)
10.	GA4223	-	Radar Distance Sensor (Use W/KM3000 Console Only)
11.	GA4229	-	Radar Sensor Mounting Bracket Package
12.	GA4230	-	Radar Sensor Pipe Mounting Package
13.	GR1082	1	KM1000 Bezel Decal, 12 Row (Used On 12 Row)
	GR1083	-	KM1000 Bezel Decal, 16 Row (Used On 8 And 16 Row)
14.	GR1080	1	KM1000 Bezel
15.	GR0595	1	Bulb, KM1000 Row Lamp
16.	GR1084	1	Bulb, KM3000 Backlite
17.	GR0866	1	Fuse, 5 Amp, Type AGC
	GR1085	1	Fuse, 2 Amp, Type AGC
18.	GD6291	-	Insulated Clamp
19.	GR0594	-	Brush
20.	GR0583	-	Console Connector Kit W/37 Pins And Shrink Tube
21.	GR0582	-	Harness Connector Kit W/37 Female Socket Contacts, Coupling Ring And Shrink Tube
22.	GR0807	-	Coupling Ring
23.	GR1171	-	Female Socket Contact
24.	GR1069	-	Shrink Tube, 2 ½"
25.	GR1067	-	Pin
26.	GR1348	-	Sound Baffle W/Pin
27.	GD4564	-	Dust Cover
28.	GD4563	-	Dust Cap
29.	GA7342	-	Adapter Cable, 4'
A.	GA6147	-	Magnetic Distance Sensor And Mounting Package (Items 5-9 And 18)

DECALS, REFLECTORS AND TIE STRAPS



1

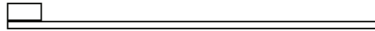

2

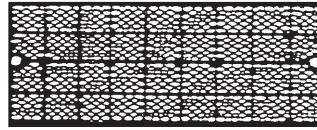

3

WARNING

EMPTY ALL HOPPERS AND INSTALL TRANSPORT PINS BEFORE TRANSPORTING.

7100-46

WARNING

TO AVOID INJURY --
STAND CLEAR—KEEP OTHERS AWAY WHEN RAISING OR LOWERING MARKERS, BEFORE TRANSPORTING PLANTER FULLY EXTEND HYDRAULIC CYLINDERS AND INSTALL LOCKING PINS WHERE PROVIDED.

7100-42

5

WARNING

1. Read and understand the Operator's Manual.
2. Stop the tractor engine before leaving the operator's platform.
3. Keep riders off the machine.
4. Make certain everyone is clear of the machine before starting the tractor engine and operating.
5. Keep all shields in place.
6. Never lubricate, adjust, unplug or service the machine with tractor engine running.
7. Wait for all movement to stop before servicing.
8. Keep hands, feet and clothing away from moving parts.
9. Use flashing warning lights when operating on highways except when prohibited by law.

7100-46

4

WARNING

TO AVOID INJURY ...
ALWAYS USE THE HYDRAULIC CYLINDER SAFETY LOCKUP CHANNEL WHEN SERVICING MACHINE IN RAISED POSITION OR WHEN TRANSPORTING MACHINE ON THE ROAD. AFTER USE RETURN TO STORAGE LOCATION.

7100-47

7

WARNING

TO AVOID INJURY
ALWAYS USE HYDRAULIC CYLINDER SAFETY LOCKOUT CHANNELS WHEN TRANSPORTING PLANTER ON THE ROAD. AFTER USE RETURN TO STORAGE LOCATION.

7100-43

8

KINZE

11

DANGER

THIS PLANTER IS DESIGNED TO BE DRIVEN BY GROUND TIRES ONLY. THE USE OF HYDRAULIC, ELECTRIC OR PTO DRIVES MAY CREATE SERIOUS SAFETY HAZARDS TO YOU AND THE PEOPLE NEARBY. IF YOU INSTALL SUCH DRIVES YOU MUST FOLLOW ALL APPROPRIATE SAFETY STANDARDS AND PRACTICES TO PROTECT YOU AND OTHERS NEAR THIS PLANTER FROM INJURY.

7100-89

9

WARNING

THIS MACHINE HAS BEEN DESIGNED AND BUILT WITH YOUR SAFETY IN MIND. DO NOT MAKE ANY ALTERATIONS OR CHANGES TO THIS MACHINE. ANY ALTERATION TO THE DESIGN OR CONSTRUCTION MAY CREATE SAFETY HAZARDS.

7100-90

10



14

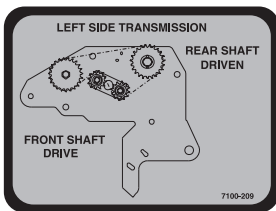

12

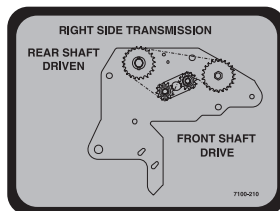

13

IMPORTANT
SEED METER ALIGNMENT TO DRIVE CLUTCH IS CRITICAL REFER TO OPERATOR'S MANUAL FOR INSTRUCTIONS

7100-182

15

WARNING

KEEP CLEAR OF LATCH AT ALL TIMES.

7100-204

16

WARNING

AGRICULTURAL CHEMICALS CAN BE DANGEROUS. IMPROPER SELECTION OR USE CAN SERIOUSLY INJURE PERSONS, ANIMALS, PLANTS, SOIL OR OTHER PROPERTY. BE SAFE, SELECT THE RIGHT CHEMICAL FOR THE JOB. HANDLE WITH CARE. FOLLOW THE INSTRUCTIONS ON THE CONTAINER LABEL AND OF THE EQUIPMENT MANUFACTURER.

7100-115

17

WARNING

STAY CLEAR OF PLANTER DURING FOLDING AND UNFOLDING.

7100-211

18

DECALS, REFLECTORS AND TIE STRAPS

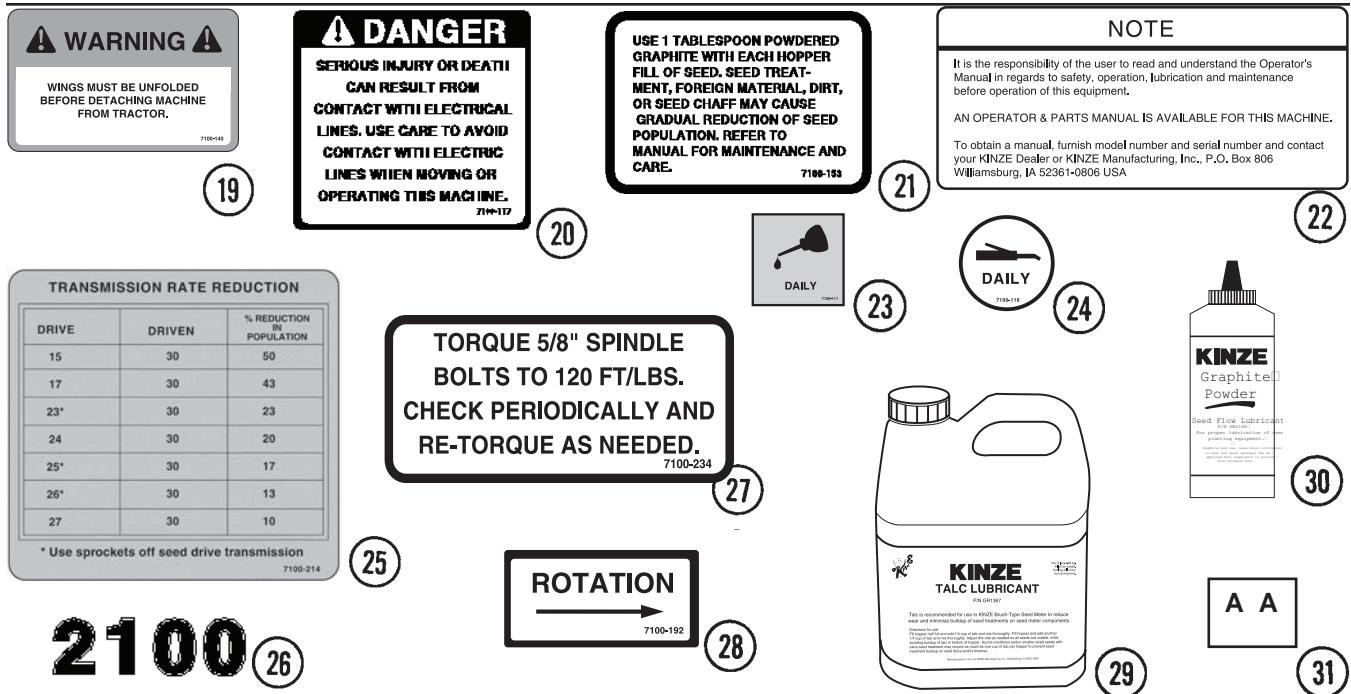

ITEM	PART NO.	QTY.	DESCRIPTION
1.	GR0155	-	Blue Paint, Aerosol
2.	GD1512	-	Tie Strap, 6"
	GD2117	-	Tie Strap, 14 1/2"
3.	G7200-03	2	Reflector, Red
	G7200-04	2	Reflector, Amber
4.	G7100-25	2	Decal, Warning
5.	G7100-42	4	Decal, Warning
6.	G7100-46	1	Decal, Warning
7.	G7100-47	2	Decal, Warning (Dual Lift Assist Wheel Package Option)
8.	G7100-83	2	Decal, Warning
9.	G7100-89	2	Decal, Danger
10.	G7100-90	1	Decal, Warning
11.	G7100-104	1	Decal, KINZE®, 3" x 12"
12.	G7100-209	1	Decal, Transmission, L.H.
13.	G7100-210	1	Decal, Transmission, R.H.
14.	G7100-195	-	Decal, Logo (2 Per Row Unit)
15.	G7100-182	-	Decal, Meter Alignment (1 Per Row Unit)
16.	G7100-204	2	Decal, Warning
17.	G7100-115	-	Decal, Warning (1 Per Granular Chemical Hopper)
18.	G7100-211	2	Decal, Warning
19.	G7100-140	1	Decal, Warning
20.	G7100-117	1	Decal, Danger
21.	G7100-153	-	Decal, Information (1 Per Brush-Type Seed Meter)
22.	G7100-217	-	Decal, Note
23.	G7100-111	-	Decal, Oil Daily
24.	G7100-116	-	Decal, Grease Daily
25.	G7100-214	-	Decal, Rate Reduction
26.	G7100-157	1	Decal, 2100
27.	G7100-234	-	Decal, Bolt Torque
28.	G7100-192	-	Decal, Point Row Clutch Rotation
29.	GR1367	-	Talc Seed Lubricant, 8 Pounds
30.	GR0146	-	Powdered Graphite, 1 Pound
31.	GD10057-01	-	Hose Identification Sleeve, Red AA Lift Extend
	GD10057-02	-	Hose Identification Sleeve, Red BB Lift Retract
	GD10057-03	-	Hose Identification Sleeve, Blue AA Marker Extend
	GD10057-04	-	Hose Identification Sleeve, Blue BB Marker Retract
	GD10057-05	-	Hose Identification Sleeve, Black AA Option Extend
	GD10057-06	-	Hose Identification Sleeve, Black BB Option Retract

ELECTRICAL COMPONENTS

PFA043(PT49/ELC9/ELC8/MTR27a)

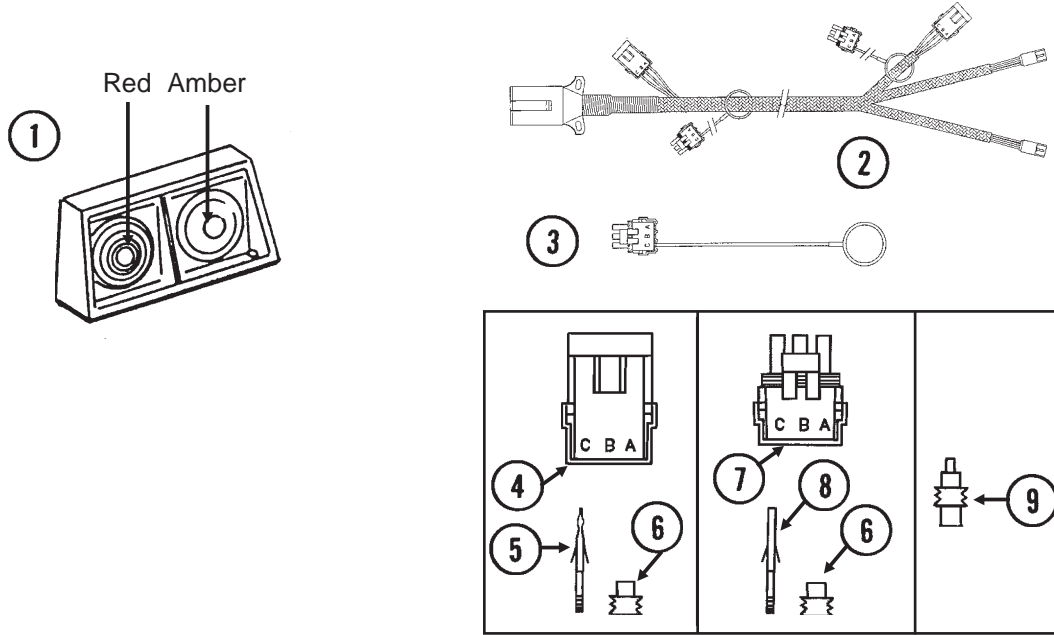

ITEM	PART NO.	QTY.	DESCRIPTION
1.	GA6699	1	Double Light Assembly (Shown)
	GA6700	1	Double Light Assembly
	GR1203	-	Red Lens
	GR1204	-	Amber Lens
	GR1205	-	Cover
	GR1206	-	Rubber Grommet (4)
	GR1207	-	Lamp Unit
	GR1208	-	Bulb
	2.	GA6816	-
GA7387		-	Light Wiring Harness W/7 Terminal Female Connector, 209", 12 Row 36"/38"/40" And 16 Row 30"
GA5385		-	7 Terminal Female Connector
3.	GA8047	-	Dust Plug
4.	GD11079	-	Housing
5.	GD11080	-	Pin Contact, No. 18
6.	GD11081	-	Seal
7.	GD11090	-	Housing
8.	GD11091	-	Socket Contact, No. 18
9.	GD11089	-	Sealing Plug
A.	G1K248	-	Harness Ends Repair Kit (3 Housings, 9 Seals, 9 Pin Contacts) (Items 4-6)
B.	G1K252	-	Harness Ends Repair Kit (3 Housings, 9 Seals, 9 Socket Contacts) (Items 6-8)

NUMERICAL INDEX

Part No.	Page	Part No.	Page	Part No.	Page
A1047	P60	G10064	P8, P29, P41, P50	G10228	P3, P22, P25, P29, P37, P39, P41, P50, P51, P52, P53, P55, P57, P58, P65
A1072	P60	G10068	P25	G10229	P2, P3, P4, P7, P8, P10, P11, P14, P17, P29, P39, P41, P43, P47, P53, P65, P73
A1102	P59	G10069	P5, P41	G10230	P4, P5, P27, P31, P35, P37, P51, P52, P55, P57
A1109	P60	G10081	P37	G10231	P31, P35, P37
A1113	P59	G10082	P31, P35	G10232	P5, P7, P10, P32, P39, P52, P55, P57
A1114	P60	G10087	P31, P35, P37	G10233	P32, P39, P41, P43, P51, P53
A1116	P61, P62, P64	G10101	P2, P3, P4, P10, P11, P14, P17, P41, P43, P47, P51, P52, P53, P71, P73	G10234	P37
A1118	P60	G10102	P7, P22, P25, P29, P37, P39, P41, P50, P51, P52, P53, P55, P57, P58, P65	G10253	P43
A1176	P60	G10103	P8, P14, P41, P43, P47, P50	G10257	P43
A1188	P59	G10104	P4, P25, P27, P31, P35, P37, P41, P51, P52, P55, P57	G10303	P7, P20, P32, P39, P52
A1198	P59, P60, P61, P62, P63, P64	G10105	P37	G10304	P3
A3191	P60	G10106	P5, P7, P21, P25, P32, P39, P41, P52, P55, P57	G10305	P2, P10, P18, P53
A3192	P60	G10107	P7, P8, P19, P21, P25, P27, P32, P39, P41	G10306	P14
A3193	P60	G10108	P3, P9, P17, P27, P29, P47, P57	G10307	P3
A3200	P60	G10109	P5, P7, P8, P20, P22, P23, P58	G10308	P18
A3201	P60	G10110	P11, P29, P52	G10309	P10
A7294	P31	G10111	P8, P9, P19, P20, P21, P22, P23, P25, P27, P29, P39, P43	G10310	P11, P14
A7331	P27	G10112	P29, P53	G10311	P17
A7549	P51	G10113	P37	G10312	P3, P10, P17
A7550	P51	G10117	P31, P35	G10315	P7
A7600	P63, P64	G10128	P39, P41, P51	G10318	P21
A7601	P63, P64	G10133	P8, P22, P23, P55, P57	G10322	P55, P57
A7804	P27	G10139	P27	G10323	P12
G10001	P2, P29, P53, P65	G10145	P41, P43, P50	G10326	P3
G10003	P3, P7, P8, P29, P43	G10148	P23	G10328	P3
G10004	P3, P4, P10, P41, P73	G10151	P27	G10343	P37
G10005	P31, P32, P35	G10152	P4, P7	G10348	P22
G10006	P7, P22	G10159	P27, P55, P57, P63, P64	G10371	P22
G10007	P37, P51	G10168	P58	G10374	P47
G10008	P25, P37, P55, P57	G10171	P7	G10396	P27
G10009	P23	G10194	P31, P35	G10397	P39, P51
G10010	P5	G10201	P3, P17	G10401	P12
G10012	P25	G10203	P43, P51	G10409	P39
G10013	P8, P39	G10204	P3, P5, P10	G10412	P4
G10014	P3	G10205	P41, P51, P55	G10427	P3, P7
G10015	P7	G10206	P3, P23, P25, P32, P39, P53, P57	G10430	P51, P53
G10016	P29	G10208	P3	G10445	P39
G10017	P20, P21, P50, P52	G10209	P11, P17, P29	G10451	P3
G10018	P5, P7	G10210	P2, P4, P7, P8, P9, P11, P17, P39, P41, P70	G10452	P14
G10019	P10, P58	G10213	P3	G10455	P10
G10020	P12	G10216	P3, P7, P20, P21, P22, P29, P52	G10457	P10
G10021	P12	G10217	P25, P27	G10459	P31, P35
G10022	P12, P17	G10218	P29	G10460	P27, P33, P37, P55, P57
G10023	P17, P29, P43, P47, P53	G10219	P7, P20, P32, P41	G10462	P38, P51
G10025	P29	G10226	P55, P57	G10463	P7
G10026	P31, P35, P37	G10227	P14, P41, P43, P47, P50	G10464	P53
G10027	P29			G10470	P12, P51
G10028	P37			G10478	P39
G10031	P41, P43, P51			G10496	P43, P47
G10032	P37			G10497	P43
G10033	P22, P39, P57			G10500	P12
G10036	P19, P25			G10501	P22, P32
G10037	P39			G10503	P3, P20, P21, P39, P51
G10039	P20, P21, P29, P57			G10504	P3
G10045	P22			G10520	P11
G10047	P29, P39, P71				
G10048	P27				
G10049	P9, P17, P43, P57				
G10055	P9, P25				
G10059	P37				
G10062	P9, P51				

NUMERICAL INDEX

Part No.	Page	Part No.	Page	Part No.	Page
G10521	P17	G10844	P58	G7100-204	P75
G10523	P14	G10857	P47	G7100-209	P75
G10526	P3	G10859	P43, P47	G7100-210	P75
G10529	P18	G10861	P32	G7100-211	P75
G10531	P13	G10863	P39	G7100-214	P75
G10536	P20, P21	G10864	P14	G7100-217	P75
G10544	P58	G10872	P47	G7100-234	P75
G10545	P4	G10873	P47	G7100-25	P75
G10546	P17, P51	G10874	P29	G7100-42	P75
G10551	P3	G10876	P47	G7100-46	P75
G10552	P3	G10880	P52	G7100-47	P75
G10553	P10	G10900	P43	G7100-83	P75
G10555	P3	G1K212	P3	G7100-89	P75
G10567	P17	G1K213	P15	G7100-90	P75
G10570	P17	G1K231	P27	G7200-03	P75
G10572	P21, P25	G1K248	P76	G7200-04	P75
G10573	P25	G1K252	P76	GA0151	P57
G10574	P19, P22, P25, P52	G1K269	P41, P43, P51	GA0167	P58
G10581	P25, P39, P41, P51, P53	G1K272	P3	GA0243	P58
G10582	P25, P41, P51	G2100-03	P32, P39, P50, P52	GA0245	P58
G10584	P13	G2404-06-06	P62	GA0257	P58
G10585	P20, P21, P27	G2501-06-08	P61, P62, P64	GA0270	P66
G10597	P20, P21	G2703-06	P59, P60, P61, P62, P63, P64	GA0378	P53
G10602	P12, P13, P17, P32, P39, P41, P51, P52	G2703-08	P60	GA0811	P2
G10603	P12, P13	G304-C-06	P60	GA0860	P3
G10604	P12	G304-C-08	P60	GA0895	P31, P35, P37
G10605	P2	G306-06	P59, P60, P61, P62, P63, P64	GA0899	P58
G10609	P17	G306-08	P60	GA1306	P3
G10610	P31, P35	G3303-114	P17	GA1676	P58
G10620	P3, P10, P11, P12, P17, P43, P51	G3303-98	P10	GA1677	P58
G10621	P10, P11, P12, P17, P18	G3305-01	P18	GA1678	P58
G10622	P3, P18	G3310-218	P32	GA1679	P58
G10637	P17	G3310-224	P32, P51	GA1720	P4
G10640	P5, P19, P25, P29	G3310-68	P38	GA2007	P10
G10641	P27, P31, P35, P37, P55, P57	G3310-74	P53	GA2012L	P3
G10660	P17	G3310-75	P41	GA2012R	P3
G10669	P3	G3314-40	P17	GA2013	P3
G10670	P17	G3400-01	P32, P39, P50, P52	GA2014	P3, P7, P9, P21, P22, P23, P25
G10680	P14	G6400-06	P65	GA2016	P10
G10689	P27	G6400-06-04	P59, P60	GA2018	P12
G10690	P12	G6400-06-08	P59, P60	GA2019	P12
G10713	P37	G6400-08	P60	GA2020	P12
G10722	P58	G6400-08-04	P60	GA2027	P11
G10724	P58	G6500-06	P59, P60, P63, P64	GA2054	P7
G10725	P58	G6500-08	P60	GA2058	P11
G10732	P4	G6505-06-06	P62	GA2068	P32
G10747	P8, P9, P25	G6602-06	P59, P64	GA2075	P14
G10751	P4	G6801-06-08	P59, P60, P63, P64	GA2076	P17
G10752	P4	G6801-08	P60	GA2094	P18
G10757	P14	G7100-104	P75	GA2147	P31, P35, P37
G10758	P14	G7100-111	P75	GA2148	P31, P35, P37
G10758	P14	G7100-115	P75	GA2180	P41
G10763	P29	G7100-116	P75	GA2327	P11
G10764	P5	G7100-117	P75	GA2558	P31, P35, P37
G10765	P43, P47	G7100-140	P75	GA4223	P73
G10770	P9	G7100-153	P75	GA4229	P73
G10801	P7	G7100-157	P75	GA4230	P73
G10804	P43, P47	G7100-182	P75	GA4235	P39
G10814	P3	G7100-192	P75	GA4312	P67
G10827	P68	G7100-195	P75	GA4353	P55
				GA4444	P17

NUMERICAL INDEX

Part No.	Page	Part No.	Page	Part No.	Page
GA4630	P38	GA5879	P73	GA7336	P39
GA4666	P27	GA5880	P3, P73	GA7338	P67
GA4705	P31, P35	GA5892	P20	GA7341	P65
GA4822	P10	GA5982	P13	GA7342	P73
GA5090	P32	GA6027	P13	GA7343	P37
GA5105	P32, P41, P51, P53	GA6038	P13	GA7345	P37
GA5106	P38, P51	GA6147	P73	GA7346	P29
GA5107	P38	GA6168	P13	GA7347	P55
GA5108	P38, P51	GA6171	P5, P7, P8	GA7348	P69
GA5109	P38, P51	GA6182	P13	GA7349	P27
GA5110	P38, P51	GA6184	P13	GA7353	P57
GA5111	P38, P51	GA6187	P13	GA7354	P57
GA5112	P38, P51	GA6434	P8	GA7357	P29
GA5113	P38	GA6443	P37	GA7359	P27
GA5114	P32, P41, P51, P53	GA6454	P37	GA7360	P29
GA5130	P55	GA6455	P37	GA7361	P29
GA5164	P53	GA6478	P13	GA7383	P29
GA5165	P53	GA6497	P29	GA7384	P29
GA5173	P55	GA6532	P55	GA7387	P76
GA5192	P55	GA6533	P39, P41, P51	GA7412	P23
GA5196	P31, P35, P37	GA6597	P8	GA7415	P57
GA5202	P39	GA6613	P8	GA7416	P45
GA5385	P76	GA6614	P5	GA7439	P73
GA5482A	P70	GA6615	P5	GA7445	P23
GA5482B	P71	GA6618	P7	GA7446	P22, P23
GA5533	P17	GA6619	P7	GA7447	P35
GA5548	P39, P51	GA6620	P7	GA7463	P47
GA5552	P65	GA6633	P13	GA7466	P27
GA5553	P15	GA6699	P76	GA7467	P27
GA5554	P15	GA6700	P76	GA7501	P67
GA5560	P15	GA6733	P7	GA7502	P69
GA5561	P15	GA6741	P14	GA7503	P69
GA5572	P65	GA6801	P7	GA7521	P67
GA5600	P73	GA6816	P76	GA7523	P68
GA5622	P19, P25	GA6832	P22	GA7524	P68
GA5623	P15	GA6833	P22	GA7525	P67
GA5625	P19	GA6834	P22	GA7526	P67
GA5630	P25	GA6838	P22	GA7570	P51
GA5631	P25	GA6907	P14	GA7571	P51
GA5635	P25	GA6937	P9	GA7574	P51
GA5636	P25	GA7116	P57	GA7577	P49
GA5637	P25	GA7118	P57	GA7580	P9
GA5640	P19, P25	GA7144	P45, P49	GA7806	P29
GA5643	P25	GA7154	P39, P41, P51, P53	GA7807	P29
GA5651	P4	GA7165	P45, P49	GA7860	P37
GA5654	P21, P22, P23, P25	GA7219	P68	GA7861	P62
GA5698	P13	GA7255	P13	GA7867	P37
GA5699	P13	GA7271	P23	GA8001	P53
GA5715	P20, P21	GA7274	P49	GA8002	P53
GA5718	P21	GA7294	P35	GA8045	P53
GA5719	P20, P21	GA7295	P31, P35	GA8047	P76
GA5746	P15	GA7297	P32	GA8172	P53
GA5794	P13	GA7298	P39	GA8174	P37
GA5795	P13	GA7301	P53	GA8328	P45, P49
GA5796	P13	GA7302	P53	GA8329	P45, P49
GA5798	P25	GA7313	P50	GA8343	P12
GA5834	P13	GA7317	P51	GA8393	P43, P47
GA5853	P58	GA7322	P35	GB0102	P2
GA5873	P73	GA7326	P29	GB0103	P3
GA5874	P73	GA7328	P29	GB0104	P3
GA5877	P73	GA7329	P29	GB0105	P2
GA5878	P73	GA7334	P27	GB0107	P10

NUMERICAL INDEX

Part No.	Page	Part No.	Page	Part No.	Page
GB0108	P10	GD10332	P32	GD1059L	P17
GB0110	P12	GD10336	P39, P51	GD1059R	P17
GB0111	P12	GD10337	P39	GD1060	P17
GB0115	P17	GD10343	P53	GD1061	P17
GB0116	P17	GD10348	P53	GD1063	P17
GB0120	P12	GD10349	P53	GD10635	P47
GB0121	P17	GD1035	P10	GD10636	P47
GB0183	P17	GD1036	P10	GD10638	P47
GB0184	P17	GD10366	P51	GD10639	P67, P69
GB0186	P4	GD1037	P10	GD1065	P3
GB0196	P25	GD10378	P29	GD1066	P2
GB0218	P4, P8, P25, P37	GD10379	P29	GD10673	P47
GB0219	P8, P9	GD1039	P12	GD10693	P47
GB0227	P19, P25	GD1040	P12	GD10694	P47
GB0233	P7, P8, P9	GD10403	P31, P35	GD10696	P51
GB0239	P7	GD10407	P39	GD10697	P50
GB0243	P10	GD1041	P12	GD10698	P47, P51
GB0245	P9	GD10412	P53	GD1072	P17
GB0254	P8	GD10418	P27	GD10733	P12
GB0258	P39, P51	GD10419	P27	GD10741	P29
GD0453-03	P57	GD1042	P12	GD10753	P4
GD0453-07	P55	GD10432	P29	GD1079	P9
GD0453-08	P55	GD10433	P29	GD1083	P12
GD0453-09	P57	GD10449	P29	GD1085	P8
GD0453-10	P57	GD1045	P12	GD1086	P5
GD0652	P55, P57	GD10450	P27	GD10867	P3
GD0737	P57	GD10454	P53	GD1089	P17
GD0746	P58	GD10456	P27	GD1090	P14
GD0752-41	P55	GD1046	P12	GD11045	P41, P43, P51
GD0840	P58	GD10464	P10, P17	GD11079	P76
GD0844	P31, P35, P37	GD10473	P3, P7	GD11080	P76
GD0914-74	P41	GD10478	P29	GD11081	P76
GD0914-98	P41	GD1048	P5	GD11089	P76
GD0917	P41, P43, P50	GD10486	P27, P33	GD1109	P4, P7, P8
GD0973	P5	GD10507	P53	GD11090	P76
GD10036	P4	GD10510	P43, P47	GD11091	P76
GD10057-01	P75	GD10519	P23	GD1110	P3
GD10057-02	P75	GD1051L	P11	GD11120	P43, P47
GD10057-03	P75	GD1051R	P11	GD1114	P4, P27, P51, P52, P57
GD10057-04	P75	GD10520	P53	GD11155	P29
GD10057-05	P75	GD10521	P53	GD1115L	P14
GD10057-06	P75	GD10525	P43	GD1115R	P14
GD10102	P43	GD10526	P23	GD1116	P14
GD10103	P43, P47	GD10527	P43	GD1118	P14
GD10104	P43	GD10528	P43	GD1120	P3
GD10105	P43	GD10529	P43	GD1121	P11
GD10106	P43	GD1053	P11	GD11219	P17
GD10109	P51	GD10532	P29	GD11239	P17
GD10120	P43, P47	GD1054	P11	GD1130	P3
GD10123	P43, P47	GD1055	P11	GD1132	P21, P22, P23, P25
GD10200	P43	GD10552	P22, P23	GD1143	P18
GD10206	P68	GD10555	P29	GD1144	P18
GD10207	P68	GD10556	P29	GD1145	P18
GD10226	P12	GD1056	P17	GD11490	P31, P35, P37
GD1026	P3, P17, P39	GD10575	P4	GD1166	P31, P35, P37
GD1027	P3	GD10577	P57	GD1255	P51, P53
GD10282	P47	GD1058	P17	GD1256	P53
GD10283	P58	GD10580	P47	GD1353	P5
GD1030	P3	GD10583	P47	GD1512	P75
GD10328	P31, P35	GD10585	P47	GD1701	P57
GD10329	P32	GD10586	P47	GD1748	P37
GD1033	P3	GD10587	P47	GD1755	P13

NUMERICAL INDEX

Part No.	Page	Part No.	Page	Part No.	Page
GD2117	P3, P73, P75	GD7805	P4, P21, P25, P31, P32,	GR0270	P31, P35, P37
GD2128	P10		P35, P37, P41, P51	GR0434	P31, P35, P37
GD2161	P55	GD7811	P25	GR0582	P73
GD2169	P37	GD7815	P25	GR0583	P73
GD2199	P53	GD7816	P25	GR0594	P73
GD2423	P14	GD7817-01	P21, P25	GR0595	P73
GD2460	P18	GD7817-04	P21, P23, P25	GR0663	P70
GD2548-111	P53	GD7817-09	P25	GR0664	P12
GD2548-58	P52	GD7818	P25	GR0676	P3, P73
GD2548-60	P52	GD7823	P21, P25	GR0709	P70
GD2548-70	P52	GD7831	P25	GR0714	P70
GD2548-81	P53	GD7878	P13	GR0716	P70
GD2548-90	P52	GD7889	P20, P21, P39, P41, P51	GR0717	P70, P71
GD2548-99	P53	GD7890	P20, P21	GR0767	P66
GD2557	P27	GD8175	P31, P35, P55	GR0807	P73
GD2558	P27, P29, P32, P38	GD8237	P13	GR0866	P73
GD2597	P58	GD8249	P4	GR0911	P41
GD2721	P55, P57	GD8266	P20	GR0912	P32, P38, P41, P51, P53
GD2947	P14	GD8307	P21, P25	GR0933	P12
GD2971-10	P17	GD8311	P37	GR0987	P67, P69
GD3180-05	P39	GD8460	P8	GR0988	P67
GD3180-15	P32, P41	GD8750	P17	GR1024	P70, P71
GD3181-12	P7	GD8751	P73	GR1025	P70
GD3214	P55	GD8770	P73	GR1026	P70
GD4086	P59, P60, P61, P62, P63,	GD8771	P73	GR1027	P70
	P64	GD8778	P13	GR1028	P70
GD4512	P57	GD8811	P5	GR1032	P65
GD4563	P73	GD8843	P19, P25	GR1033	P65
GD4564	P73	GD8844	P19, P25	GR1034	P65
GD5212	P53	GD9052	P29	GR1035	P65
GD5752	P32	GD9120	P8	GR1036	P65
GD5753	P32	GD9170	P37	GR1037	P65
GD5792	P39	GD9179	P37	GR1038	P65
GD5804	P31, P35	GD9208	P37	GR1039	P65
GD5805	P39	GD9240	P3, P17	GR1040	P65
GD5857	P22, P39, P41, P51	GD9254	P19, P25	GR1041	P65
GD5860	P41, P51	GD9290	P7	GR1042	P65
GD5875	P57	GD9305	P7	GR1043	P65
GD5892	P29, P55	GD9333	P27	GR1044	P65
GD6291	P73	GD9378	P53	GR1045	P65
GD6501	P12	GD9529	P45, P49	GR1046	P65
GD6533	P3, P7	GD9530	P45, P49	GR1047	P65
GD6568	P67	GD9562	P7	GR1048	P65
GD6569	P67	GD9667	P43	GR1062	P3, P73
GD6772	P57	GD9671	P43, P47	GR1066	P10
GD7041	P31, P35	GD9672	P43, P47	GR1067	P73
GD7127	P38, P51	GD9707	P29	GR1069	P73
GD7145	P43, P65	GD9708	P29	GR1077	P73
GD7148	P17	GD9715	P22	GR1078	P73
GD7164	P67, P69	GD9720	P22	GR1079	P73
GD7209	P57	GD9724	P22, P23	GR1080	P73
GD7258	P17	GD9750	P27	GR1082	P73
GD7318	P3	GD9786	P9	GR1083	P73
GD7426	P39	GD9787	P9	GR1084	P73
GD7588	P17	GD9816	P14	GR1085	P73
GD7589	P17	GR0146	P75	GR1087	P3, P73
GD7591	P17	GR0150	P58	GR1171	P73
GD7592	P17	GR0151	P58	GR1203	P76
GD7618	P10	GR0155	P75	GR1204	P76
GD7619	P4	GR0181	P70, P71	GR1205	P76
GD7803	P19, P25	GR0193	P70, P71	GR1206	P76
GD7804	P19, P25	GR0196	P10, P17	GR1207	P76

NUMERICAL INDEX

Part No.	Page	Part No.	Page	Part No.	Page
GR1208	P76				
GR1270	P71				
GR1271	P71				
GR1272	P71				
GR1273	P71				
GR1274	P71				
GR1276	P71				
GR1278	P71				
GR1279	P71				
GR1294	P53				
GR1295	P53				
GR1300	P53				
GR1301	P53				
GR1303	P43, P47				
GR1304	P43, P47				
GR1305	P43, P47				
GR1306	P43, P47				
GR1308	P68				
GR1309	P68				
GR1327	P12				
GR1345	P45				
GR1346	P45, P49				
GR1347	P45, P49				
GR1348	P73				
GR1352	P53				
GR1355	P45				
GR1357	P67, P69				
GR1361	P49				
GR1362	P49				
GR1365	P53				
GR1367	P75				
GR1447	P45				
GR1448	P49				
GR1449	P49				
GR1450	P45				